

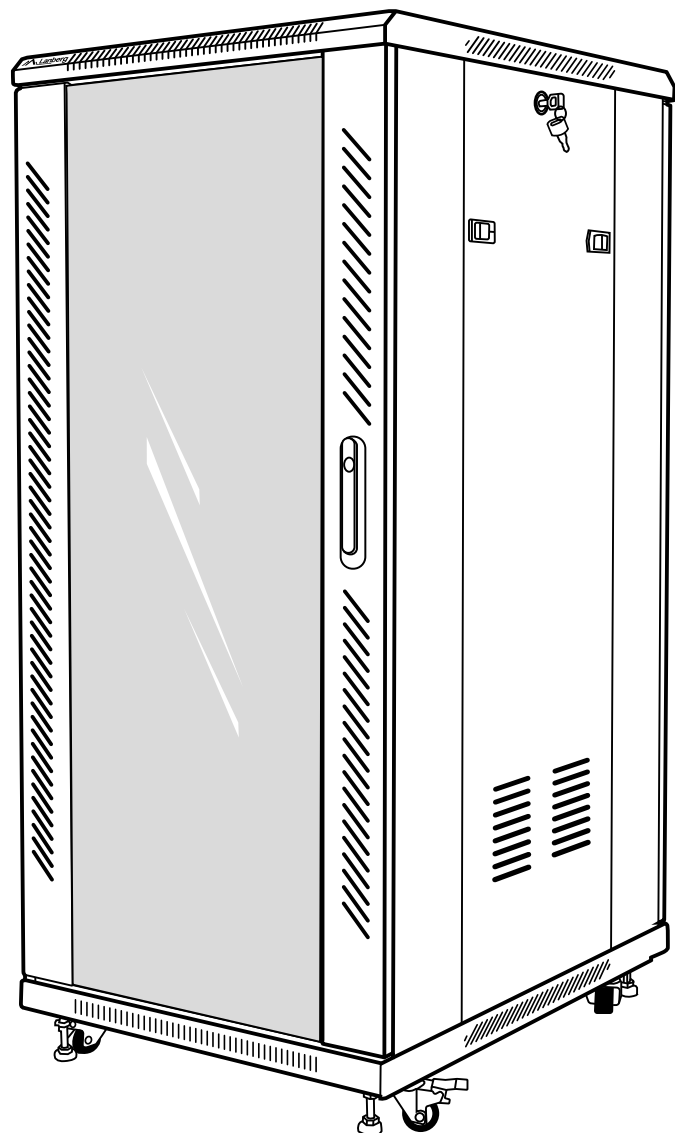

19" Rack cabinets

FF01 15U, 22U, 27U, 32U, 37U, 42U, 600*600, 600*800 series

User's manual



EN 3
FR 10
ES 17
PT 24
DE 31
SE 38
IT 45
PL 52
CZ 59
SK 66
RO 73
BG 80
HU 87
RS 94
RU 101
GR 108

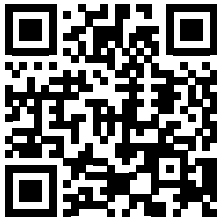
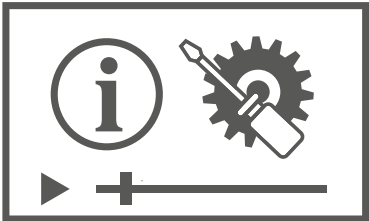

EN Safety information:

Installation by minimum 2 persons only.
 Secure the cabinet to the floor or wall at designated anchoring points.
 Do not exceed total load capacity or shelf / 1U load.
 Install the heaviest equipment at the lowest positions (first bottom U).
 Distribute the load evenly; secure equipment with mounting screws.
 Before moving, remove all equipment and lock the doors.
 Use only recommended casters and mounting hardware — check load rating.
 Ground the cabinet according to local grounding requirements for equipment and metal enclosures.
 Maintain required ventilation clearances — do not block perforations.
 Beware of sharp edges — protective gloves recommended.
 Periodic inspection: check fasteners every 12 months; verify grounding per local requirements.
 Do not use outdoors or in high-humidity or corrosive environments.

FR Instructions de sécurité :

Installation par au moins 2 personnes.
 Fixer l'armoire au sol ou au mur aux points d'ancrage prévus.
 Ne pas dépasser la charge totale ni la charge par étagère / 1U.
 Installer les équipements les plus lourds en bas (premier U inférieur).
 Répartir la charge uniformément ; fixer les appareils avec des vis.
 Avant de déplacer, retirer tout l'équipement et verrouiller les portes.
 Utiliser uniquement les roulettes et fixations recommandées — vérifier la capacité de charge.
 Mettre l'armoire à la terre conformément aux exigences locales pour les équipements et boîtiers métalliques.
 Maintenir les dégagements de ventilation requis — ne pas obstruer les perforations.
 Attention aux bords tranchants — gants de protection recommandés.
 Contrôles périodiques : vérifier les fixations tous les 12 mois ; vérifier la mise à la terre selon les exigences locales.
 Ne pas utiliser à l'extérieur ni en environnement humide ou corrosif.

ES Instrucciones de seguridad:

Instalación únicamente por un mínimo de 2 personas.
 Fijar el armario al suelo o pared en los puntos designados.
 No exceder la carga total ni la carga por estante / 1U.
 Instalar los equipos más pesados en la parte inferior (primer U inferior).
 Distribuir la carga de manera uniforme; asegurar los equipos con tornillos de montaje.
 Antes de mover, retirar todo el equipo y bloquear las puertas.
 Usar solo ruedas y elementos de fijación recomendados — comprobar la capacidad de carga.
 Conectar a tierra el armario de acuerdo con los requisitos locales de puesta a tierra para equipos y envoltorios metálicos.
 Mantener los espacios de ventilación requeridos — no bloquear las perforaciones.
 Cuidado con los bordes cortantes — se recomiendan guantes de protección.
 Inspecciones periódicas: comprobar los anclajes cada 12 meses; revisar la puesta a tierra según los requisitos locales.
 No usar en exteriores ni en entornos de alta humedad o corrosivos.

PT Instruções de segurança:

Instalação por no mínimo 2 pessoas.
 Fixar o armário ao chão ou parede nos pontos de ancoragem indicados.
 Não exceder a capacidade de carga total nem a carga por prateleira / 1U.
 Instalar os equipamentos mais pesados na parte inferior (primeiro U inferior).
 Distribuir a carga de forma uniforme; fixar os equipamentos com parafusos de montagem.
 Antes de deslocar, remover todo o equipamento e travar as portas.
 Usar apenas rodízios e elementos de fixação recomendados — verificar a capacidade de carga.
 Aterre o armário conforme os requisitos locais de aterramento para equipamentos e invólucros metálicos.
 Manter os espaços de ventilação exigidos — não bloquear as perfurações.
 Cuidado com bordas cortantes — luvas de proteção recomendadas.
 Inspeções periódicas: verificar as fixações a cada 12 meses; verificar o aterramento conforme os requisitos locais.
 Não usar ao ar livre nem em ambientes de alta humidade ou corrosivos.

DE Sicherheitshinweise:

Montage nur durch mindestens 2 Personen.
 Schrank an Boden oder Wand an den vorgesehenen Befestigungspunkten verankern.
 Gesamttraglast sowie Traglast pro Fach / 1U nicht überschreiten.
 Die schwersten Geräte an den unteren Positionen installieren (erstes unteres U).
 Die Last gleichmäßig verteilen; Geräte mit Montageschrauben sichern.
 Vor dem Transport sämtliche Geräte entfernen und Türen verriegeln.
 Nur empfohlene Rollen und Befestigungsmaterial verwenden — Tragfähigkeit prüfen.
 Den Schrank gemäß den lokalen Erdungsanforderungen für Geräte und Metallgehäuse erden.
 Energie- und Belüftungsabstände einhalten — Perforationen nicht blockieren.
 Vorsicht vor scharfen Kanten — Schutzhandschuhe empfohlen.
 Periodische Überprüfung: Befestigungen alle 12 Monate prüfen; Erdung gemäß lokalen Vorschriften verifizieren.
 Nicht im Freien oder in Bereichen mit hoher Luftfeuchtigkeit oder korrosiven Bedingungen verwenden.

SE Säkerhetsinstruktioner:

Montering endast av minst 2 personer.
 Fäst skåpet i golvet eller väggen vid angivna förankringspunkter.
 Överskrid inte den totala lastkapaciteten eller last per hylla / 1U.
 Installera de tyngsta enheterna i de lägsta positionerna (första nedre U).
 Fördela lasten jämnt; säkra utrustningen med monteringskruvar.
 Innan förflyttning, ta bort all utrustning och lås dörrarna.
 Använd endast rekommenderade hjul och fästelement — kontrollera lastkapacitet.
 Jorda skåpet enligt lokala jordningskrav för utrustning och metallhöljen.
 Behåll erforderliga ventilationsutrymmen — blockera inte perforeringar.
 Se upp för vassa kanter — skyddshandskar rekommenderas.
 Periodisk inspektion: kontrollera fästen var 12:e månad; verifiera jordning enligt lokala krav.
 Använd inte utomhus eller i miljöer med hög luftfuktighet eller korrosiva förhållanden.

IT Istruzioni di sicurezza:

Installazione esclusivamente da parte di almeno 2 persone.
 Fissare l'armadio al pavimento o alla parete nei punti di ancoraggio indicati.
 Non superare il carico totale né il carico per ripiano / 1U.
 Installare le apparecchiature più pesanti nelle posizioni più basse (primo U inferiore).
 Distribuire uniformemente il carico; fissare le apparecchiature con viti di montaggio.
 Prima dello spostamento, rimuovere tutte le apparecchiature e bloccare le porte.
 Usare solo ruote e elementi di fissaggio raccomandati — verificare la portata.
 Collegare a terra l'armadio secondo i requisiti locali per la messa a terra di apparecchiature e involucri metallici.
 Mantenere i necessari spazi di ventilazione — non ostruire le perforazioni.
 Attenzione ai bordi taglienti — guanti protettivi consigliati.
 Ispezioni periodiche: controllare i fissaggi ogni 12 mesi; verificare la messa a terra secondo i requisiti locali.
 Non usare all'aperto né in ambienti ad alta umidità o corrosivi

PL Instrukcja bezpieczeństwa:

Montaż wyłącznie przez minimum 2 osoby.
 Przymocować szafę do podłoża lub ściany w oznaczonych punktach kotwienia.
 Nie przekraczać udźwigu całkowitego oraz udźwigu na półkę / 1U.
 Najcięższe urządzenia instalować najniżej (pierwsze dolne U).
 Równomiernie rozłożyć obciążenie; zabezpieczyć urządzenia śrubami montażowymi.
 Przed przemieszczaniem usunąć cały sprzęt i zablokować drzwi.
 Używać tylko zalecanych kółek i elementów mocujących — sprawdzić nośność.
 Uziemić szafę zgodnie z lokalnymi wymogami dotyczącymi uziemiania urządzeń i metalowych obudów.
 Zachować wymagane odstępstwa wentylacyjne — nie zasłaniać perforacji.
 Uważać na ostre krawędzie — zalecane rękawice ochronne.
 Przeglądy okresowe: sprawdzić mocowania co 12 mies.; uziemienie sprawdzić zgodnie z lokalnymi wymogami.
 Nie używać na zewnątrz ani w warunkach wysokiej wilgotności lub korozyjnych.

CZ Bezpečnostní pokyny:

Montáž pouze minimálně dvěma osobami.
Připevněte skříň k podlaze nebo ke stěně v určených bodech kotvení.
Nepřekračujte celkovou nosnost ani nosnost na polici / 1U.
Nejtěžší zařízení instalujte nejnižší (první spodní U).
Zatížení rovnoměrně rozložte; zařízení zajistěte montážními šrouby.
Před přemístěním vyjměte veškeré vybavení a zamkněte dveře.
Používejte pouze doporučená kolečka a upevňovací prvky — zkontrolujte nosnost.
Uzemněte skříň podle místních požadavků na uzemnění zařízení a kovových krytů.
Zachovejte požadované ventilační odstupy — neblokujte perforace.
Dejte pozor na ostré hrany — doporučeny ochranné rukavice.
Pravidelné prohlídky: kontrola upevnění každých 12 měsíců; ověření uzemnění dle místních požadavků.
Nepoužívejte venku ani v podmínkách vysoké vlhkosti nebo korozivních prostředích.

SK Bezpečnostné pokyny:

Montáž výlučne minimálne 2 osobami.
Prípnúť skrinku k podlahe alebo stene v označených bodoch kotvenia.
Neprekračovať celkovú nosnosť ani nosnosť na policu / 1U.
Najťažšie zariadenia inštalovať najnižšie (prvé dolné U).
Rovnomerne rozložiť zaťaženie; zabezpečiť zariadenia montážnymi skrutkami.
Pred presunom odstrániť všetko vybavenie a zamknúť dvere.
Používať len odporúčané kolieska a upevňovacie prvky — skontrolovať nosnosť.
Uzemniť skrinku v súlade s miestnymi požiadavkami na uzemnenie zariadení a kovových krytov.
Zachovať požadované vetracie odstupy — nezakrývať perforácie.
Dávať pozor na ostré hrany — odporúčané ochranné rukavice.
Pravidelné kontroly: skontrolovať upevnenia každých 12 mesiacov; kontrolovať uzemnenie podľa miestnych požiadaviek.
Nepoužívať vonku ani v prostredí s vysokou vlhkosťou alebo korozívnymi podmienkami.

RO Instrucțiuni de siguranță:

Montaj numai de către minimum 2 persoane.
Fixați dulapul de podea sau perete în punctele de ancorare indicate.
Nu depășiți capacitatea totală de încărcare sau sarcina pe raft / 1U.
Instalați echipamentele cele mai grele în pozițiile cele mai joase (primul U inferior).
Distribuiți sarcina uniform; fixați echipamentele cu șuruburi de montaj.
Înainte de mutare, scoateți toate echipamentele și blocați ușiile.
Utilizați numai roți și elemente de fixare recomandate — verificați capacitatea de încărcare.
Împământați dulapul conform cerințelor locale pentru împământarea echipamentelor și carcaselor metalice.
Păstrați spațiile de ventilație necesare — nu blocați perforațiile.
Aveți grijă la muchii ascuțite — mănuși de protecție recomandate.
Inspecții periodice: verificați elementele de fixare la fiecare 12 luni; verificați împământarea conform cerințelor locale.
Nu utilizați în aer liber sau în medii cu umiditate ridicată sau corozive.

BG Инструкции за безопасност:

Монтаж само от минимум 2 души.
Закрепете шкафа към пода или стената в посочените точки за закотвяне.
Не превишавайте общата товароносимост и товароносимостта на рафт / 1U.
Най-тежките устройства инсталирайте най-надолу (първото долно U).
Разпределете натоварването равномерно; закрепете устройствата с монтажни винтове.
Преди преместване премахнете цялото оборудване и заключете вратите.
Използвайте само препоръчаните колела и крепежни елементи — проверете товароносимостта.
Заземете шкафа съгласно местните изисквания за заземяване на оборудване и метални обвивки.
Съхранявайте необходимите вентилационни разстояния — не блокирайте перфорациите.
Внимавайте за остри ръбове — препоръчват се предпазни ръкавици.
Периодични прегледи: проверявайте крепежите на всеки 12 месеца; проверявайте заземяването според местните изисквания.
Не използвайте на открито или в условия на висока влажност или корозивна среда.

HU Biztonsági utasítások:

Összeszerelés kizárólag legalább 2 személy által.
Rögzítse a szekrényt a padlóhoz vagy a falhoz a megjelölt rögzítési pontokon.
Ne lépje túl a teljes teherbírást és a polconkénti / 1U teherbírást.
A legnehezebb berendezéseket a legalacsonyabb pozíciókba szerelje (első alsó U).
Ossza el egyenletesen a terhelést; rögzítse a berendezést szerelvényis kímí csavarokkal.
Mozgatás előtt távolítsa el minden felszerelést és zárja le az ajtókat.
Használjon csak ajánlott görgőket és rögzítőelemeket — ellenőrizze a teherbírást.
Földelje a szekrényt a helyi földelési előírásoknak megfelelően.
Tartsa meg a szükséges szellőztőtávolságokat — ne takarja el a perforációkat.
Vigyázzon az éles élekre — védőkesztyű ajánlott.
Időszakos ellenőrzés: ellenőrizze a rögzítéseket 12 havonta; ellenőrizze a földelést a helyi előírásoknak megfelelően.
Ne használja kültéren vagy magas páratartalmú, korrozív környezetben.

RS Инструкције за безбедност:

Монтажа искључиво од стране најмање 2 особе.
Приклоните орман за под или зид на назначеним тачкама за учвршћивање.
Не прелазите укупни корисни терет нити терет по полици / 1U.
Најтежу опрему инсталирајте најниже (прво доње U).
Распоредите оптерећење равномерно; обезбедите опрему монтажним вијцима.
Пре премештања уклоните сву опрему и заључајте врата.
Користите само препоручена тачка и елементе за учвршћивање — проверите носивост.
Заземљите орман у складу са локалним захтевима за уземљење опреме и металних кућишта.
Одржавајте потребне вентилацијске размаке — не блокирајте перфорације.
Пазите на оштре ивице — препоручују се заштитне рукавице.
Периодични прегледи: проверите причвршћења на сваких 12 месеци; проверите уземљење према локалним захтевима.
Не користите напољу или у условима велике влажности или корозивног окружења.

RU Инструкция по безопасности:

Монтаж исключительно минимум двумя людьми.
Закрепите шкаф на полу или стене в указанных точках крепления.
Не превышайте общую грузоподъемность и грузоподъемность на полку / 1U.
Самое тяжелое оборудование устанавливайте внизу (первое нижнее U).
Равномерно распределяйте нагрузку; закрепляйте оборудование монтажными винтами.
Перед перемещением удалите все оборудование и заблокируйте двери.
Используйте только рекомендованные колесики и крепежные элементы — проверьте грузоподъемность.
Заземлите шкаф в соответствии с местными требованиями по заземлению оборудования и металлических корпусов.
Соблюдайте требуемые вентиляционные зазоры — не закрывайте перфорацию.
Осторожно: острые кромки — рекомендуется защитные перчатки.
Периодические осмотры: проверяйте крепления каждые 12 месяцев; проверяйте заземление согласно местным требованиям.
Не использовать на открытом воздухе или в условиях высокой влажности или коррозионной среды.

GR Οδηγίες ασφάλειας:

Εγκατάσταση μόνο από τουλάχιστον 2 άτομα.
Στερεώστε το ντουλάπι στο δάπεδο ή στον τοίχο στα καθορισμένα σημεία αγκύρωσης.
Μην υπερβείτε τη συνολική χωρητικότητα φορτίου ή το φορτίο ανά ράφι / 1U.
Εγκαταστήστε τον πιο βαρύ εξοπλισμό στις χαμηλότερες θέσεις (πρώτο κάτω U).
Καταβείτε το φορτίο ομοιόμορφα· ασφαλίστε τον εξοπλισμό με βίδες στήριξης.
Πριν από τη μετακίνηση, αφαιρέστε όλο τον εξοπλισμό και κλειδώστε τις πόρτες.
Χρησιμοποιήστε μόνο τους συνιστώμενους τροχούς και εξαρτήματα στερέωσης — ελέγξτε την αντοχή φόρτωσης.
Γειώστε το ντουλάπι σύμφωνα με τις τοπικές απαιτήσεις γείωσης για τον εξοπλισμό και τα μεταλλικά περιβλήματα.
Διατηρήστε τις απαιτούμενες αποστάσεις αερισμού — μην καλύπτετε τις οπές διάτρησης.
Προσοχή σε αιχμηρές ακμές — συνιστώνται προστατευτικά γάντια.
Περιοδικός έλεγχος: ελέγξτε τα στερεώματα κάθε 12 μήνες· επαληθεύστε τη γείωση σύμφωνα με τις τοπικές απαιτήσεις.
Μην το χρησιμοποιείτε σε υπαίθριους χώρους ή σε περιβάλλοντα υψηλής υγρασίας ή διαβρωτικά.









1. Assembly Instructions





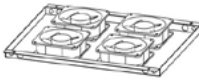

i *Be sure to strictly follow the instructions in this manual.*

1.1 Preparations

Prepare the appropriate amount of free space on the surface on which the assembly will take place. Carefully remove all elements from the transport box. Further assembly instructions will be based on the diagram provided

1.1.1. Accessory Table

| Cabinet parts | | | | |
|---------------|------------------|---|--------------------------------|---------------|
| Item No. | Item name | Item drawing | Number required | Number in set |
| Item A | Front glass door |  | 1 pc. | 1 pc. |
| Item B | Back panel |  | 1 pc. | 1 pc. |
| Item C | Side panels |  | 2 pcs | 2 pcs |
| Item D | Frame |  | 2 pcs | 2 pcs |
| Item E | Top cover |  | 1 pc. | 1 pc. |
| Item F | Lower cover |  | 1 pc. | 1 pc. |
| Item G | Crossbar |  | 15U~27U 4 pcs 32U~42U 6 pcs | |
| Item H | Fan shelf |  | 1 pc. | 1 pc. |
| Item I | Mounting rails |  | 4 pcs | 4 pcs |
| Item J | Top panel cap |  | Flat 3 pcs Grooved 4 pcs | |

| | | | | |
|--------|--------------------|--|---------------------------------|-------|
| Item K | Adjustable feet |  | 4 pcs | 4 pcs |
| Item L | Wheels with brakes |  | 4 pcs | 4 pcs |
| Item M | Door stops |  | 15U~27U 8 pcs 32U~42U 12 pcs | |
| Item N | Front door lock |  | 1 pc. | 1 pc. |
| Item O | Rear panel lock |  | 3 pcs | 3 pcs |
| Item W | Door spacers |  | 2 pcs | 4 pcs |

| Screws | | | | |
|----------|-------------------------------|---|-----------------|---------------|
| Item No. | Item name | Item drawing | Number required | Number in set |
| Item Q | M8 Allen screw |  | 16 pcs | 17 pcs |
| Item R | M5*10 Self-tapping screws |  | 15U~27U 36 pcs | 40 pcs |
| | | | 32U~42U 44 pcs | 50 pcs |
| Item S | M4*8 Self-tapping screws |  | 15U~27U 20 pcs | 23 pcs |
| | | | 32U~42U 26 pcs | 30 pcs |
| Item T | M6 Snap nut |  | 15U~27U 32 pcs | 35 pcs |
| | | | 32U~42U 48 pcs | 50 pcs |
| Item U | M6x12 Allen screw |  | 15U~27U 32 pcs | 35 pcs |
| | | | 32U~42U 48 pcs | 52 pcs |
| Item V | M6 Additionally screw and nut |  | 20 pcs | 20 pcs |

2. Assembly stages

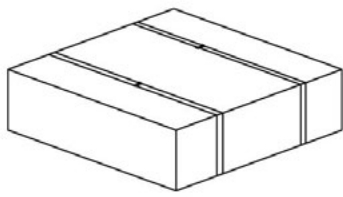

**TOP AND BOTTOM
PACKAGE 1/3**

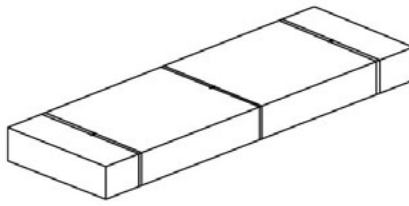

**FRONT DOOR, REAR PANEL
AND SIDE PANEL 2/3**

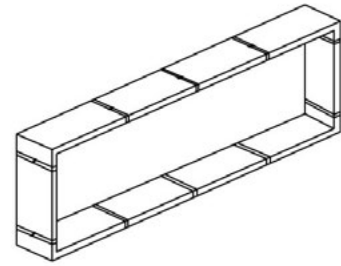

FRAME PACKAGE 3/3

Step 1. Remove the front door lock (item N), the side panel locks and the rear panel lock (item O), the components are in pack 1/3. Then remove the front glass door (item A), back panel (item B) and side panels (item C) from pack 2/3. At this stage we start by fitting locks to the above components.



Step 2. Unpack the frame parts (item J) from pack 3/3. Then arrange the frames parallel to each other, with the square holes facing inwards. You can recognize the lower part of the frame by the element for installing the earthing.

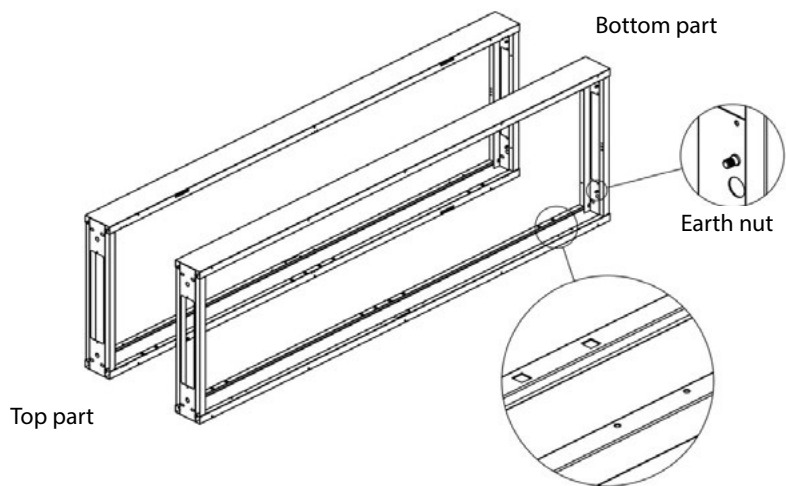

Step 3. Fit the top cover (item E) onto the top parts of the frame (item D), then use an M8 Allen screw (item Q) to assemble them together.

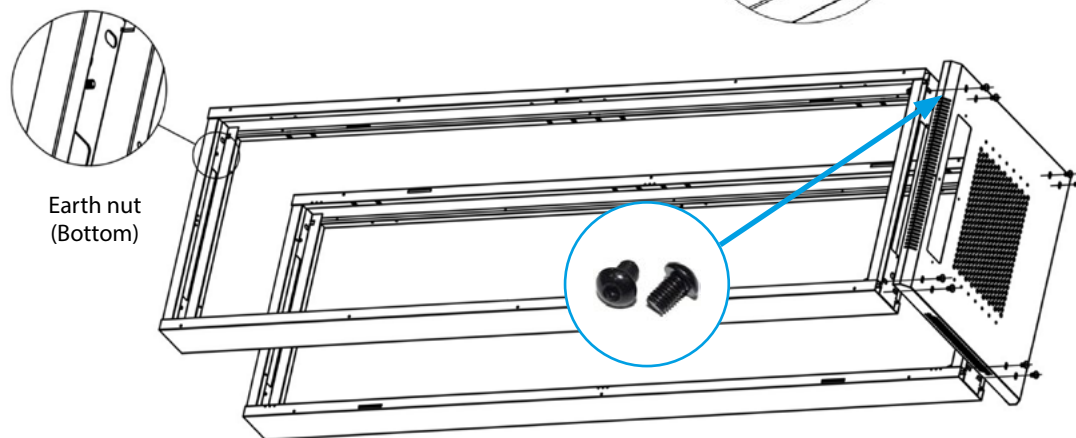

Step 4. Fit the lower cover (item F) onto the lower part of the frame (item D) and then use an M8 Allen bolt (item Q) to join them together.

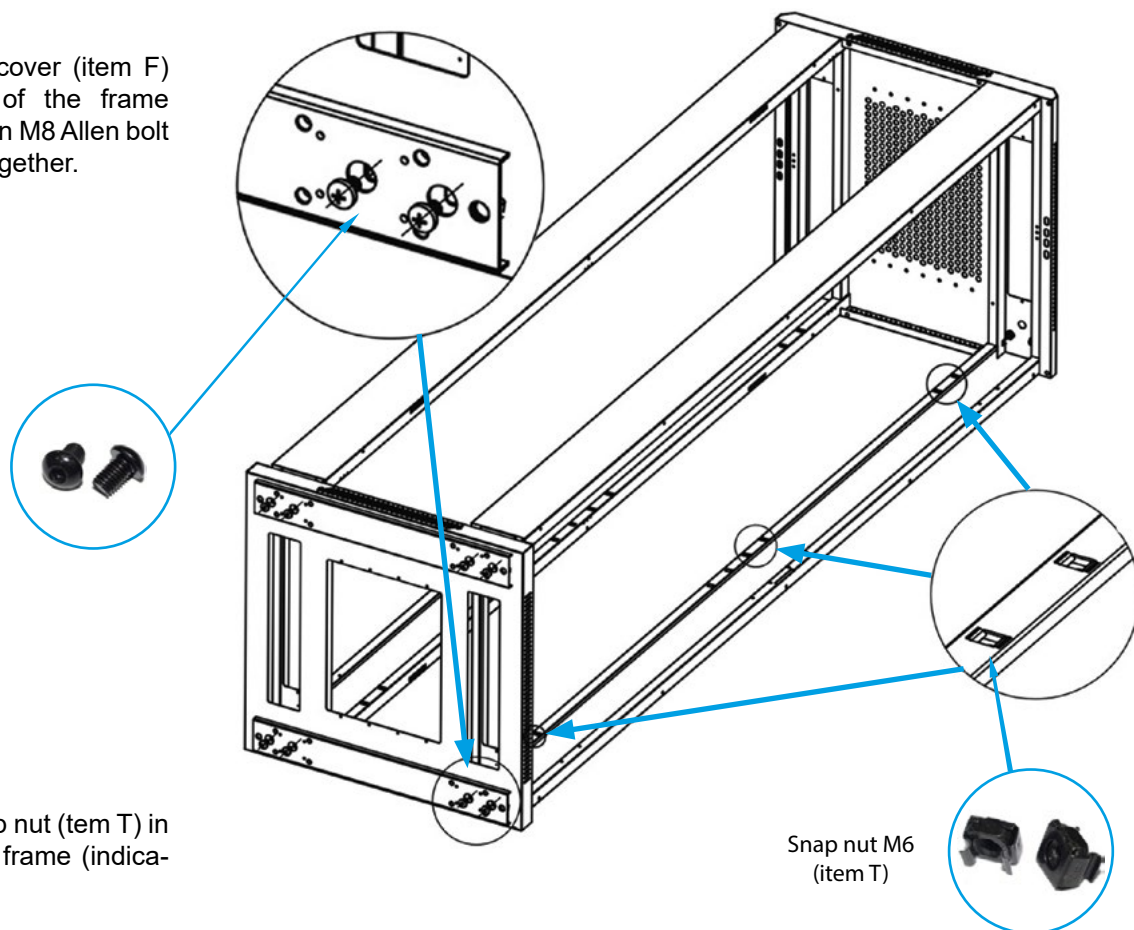

Step 4a. Fit an M6 snap nut (tem T) in the square hole in the frame (indicated in the figure).

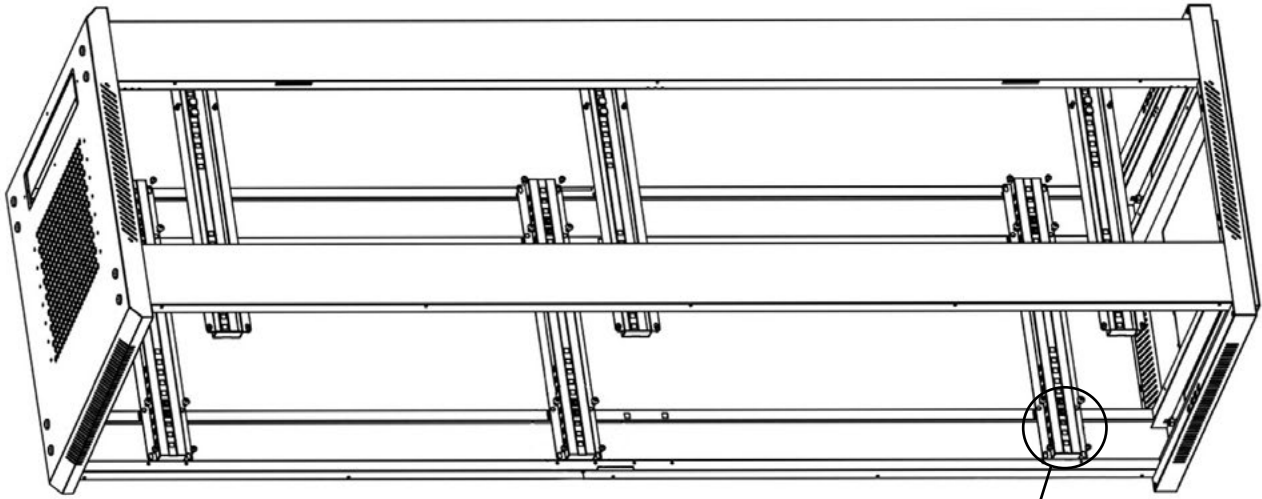

Allen head bolt M6
(item U)

Step 5. Prepare M6 snap nuts (item T) and fix them on the crossbar (item G), then place the crossbar on the frame (item D) avoiding the locking hole in the frame. Use an M6 Allen screw (item U) and an M5 self-tapping screw (item R) to fix the crossbar.

Self-tapping screw M5
(item R)

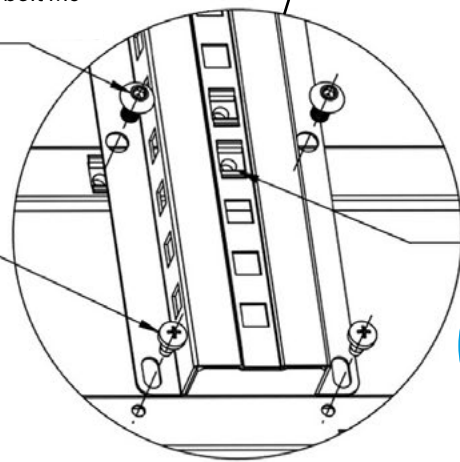

Snap nut M6
(item T)

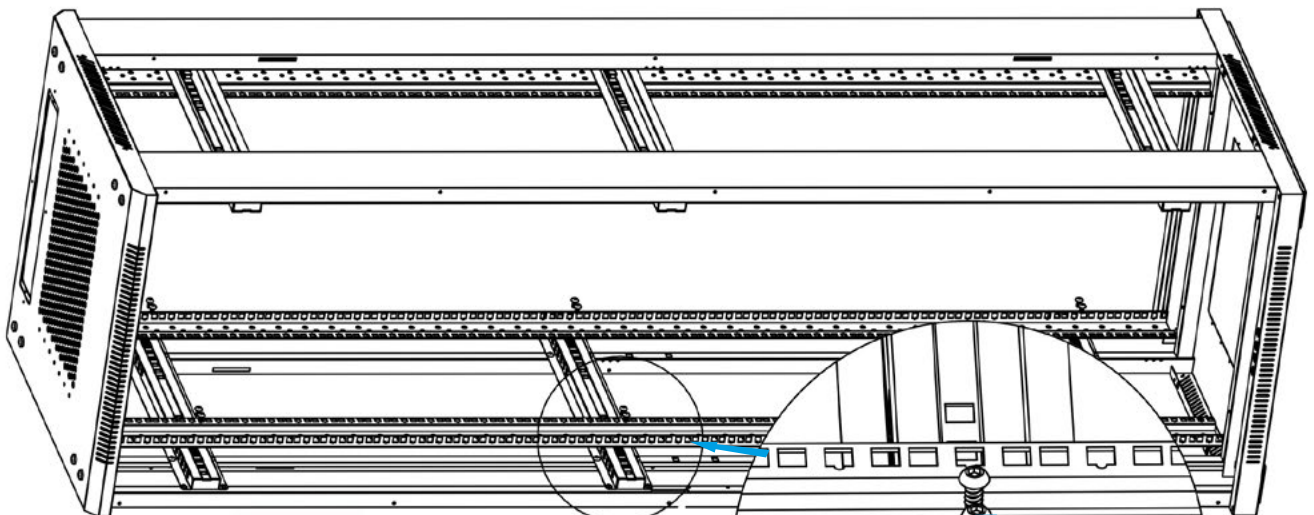

Step 6. Prepare M6 mounting screws (item U). Use screws to fix the vertical mounting rails (item I) to the horizontal crossbars (item G).



Allen head bolt M6
(item U)

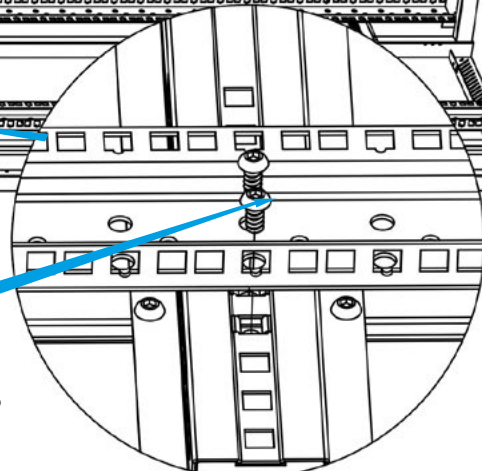

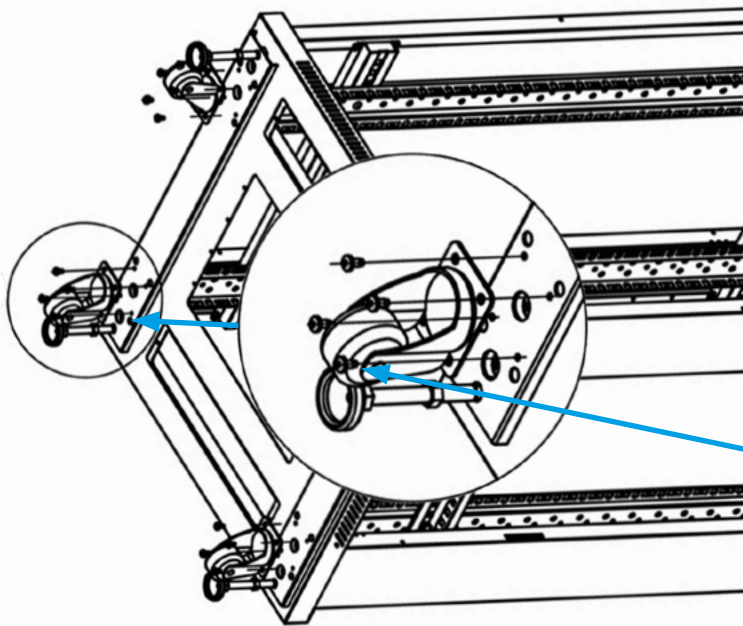

Step 7. Prepare M5 self-tapping screws (item R) to fix the four wheels with brakes (item L) on the bottom cover (item F). Then mount the adjustable feet (item K) to the bottom cover.



Self tapping screw M5 (item R)

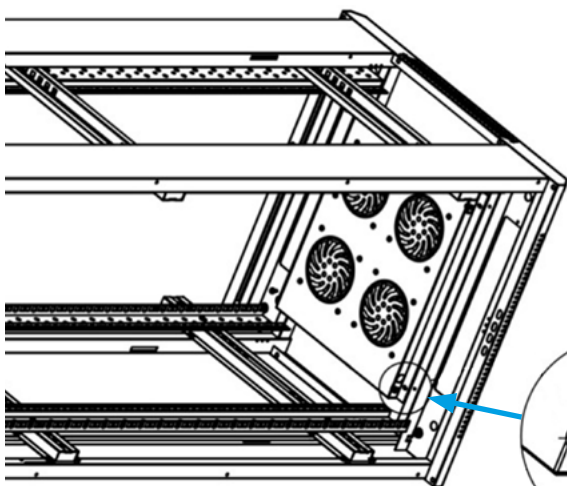

Step 8. Prepare M5 self-tapping screws (item R), then use them to attach the fan shelf (item H) to the RACK frame (item D).



Self tapping screw M5 (item R)

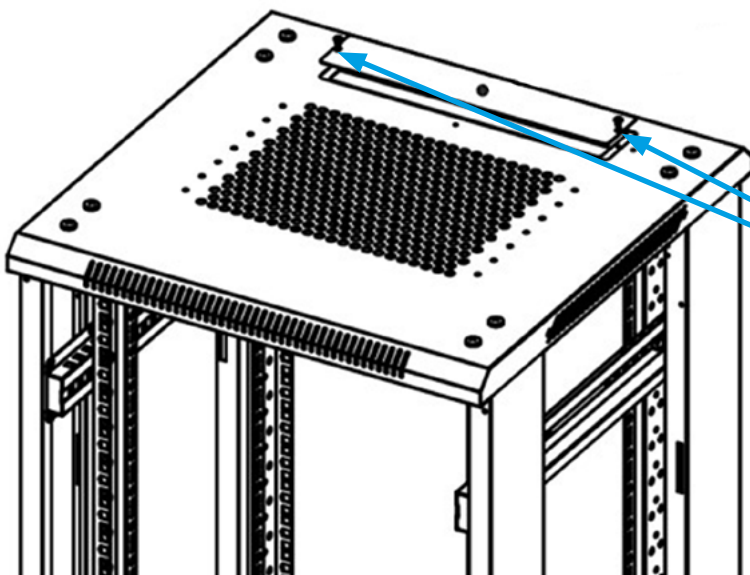

Step 9. Prepare and use an M4 self-tapping screw (item S) to attach the top panel cap (item J).



Self-tapping screw M4 (item S)

Step 10. Prepare and use M4 self-tapping screws (item S) to fix the door stops (item M). For sizes 15U~27U (8 pcs), 32U~47U (12 pcs).



Self-tapping screw M4
(item S)

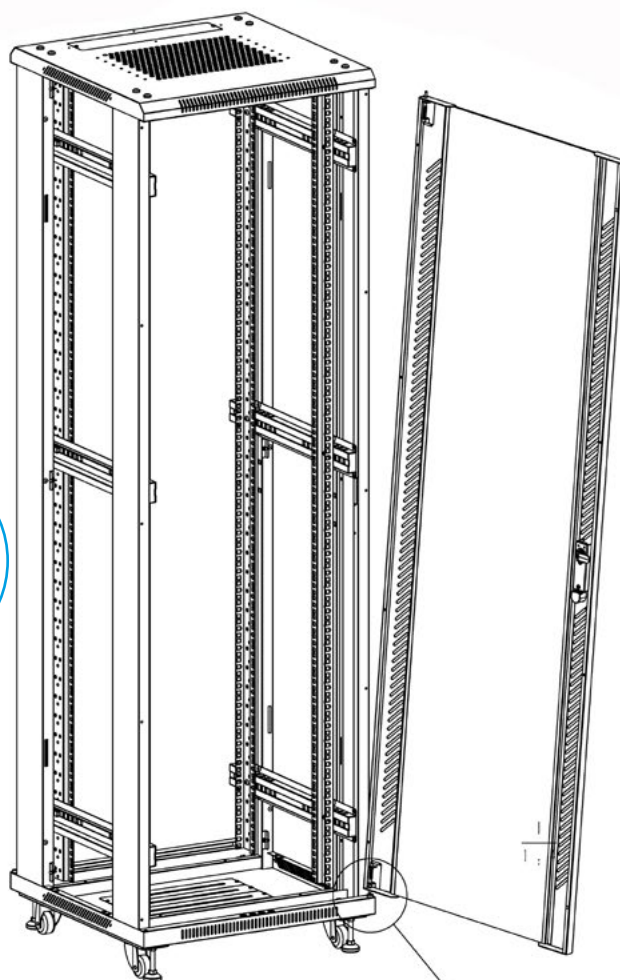
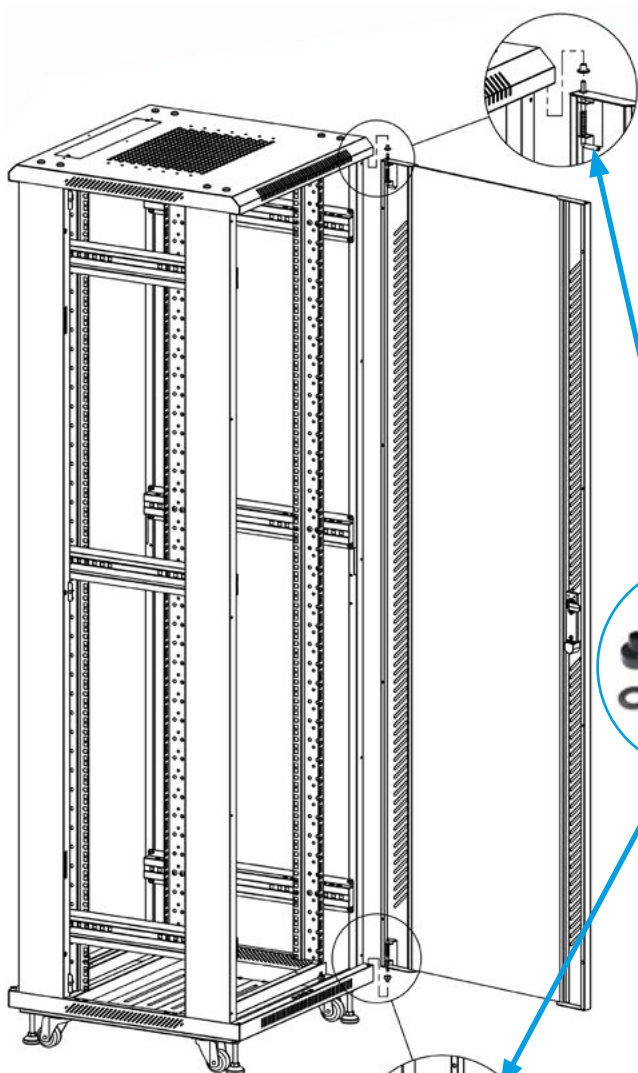
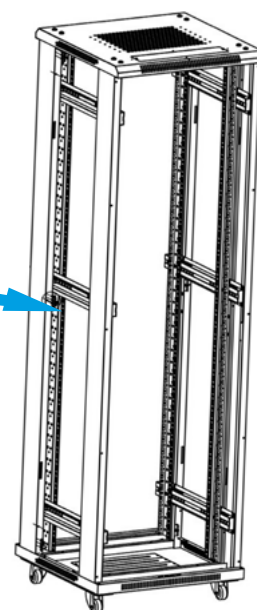
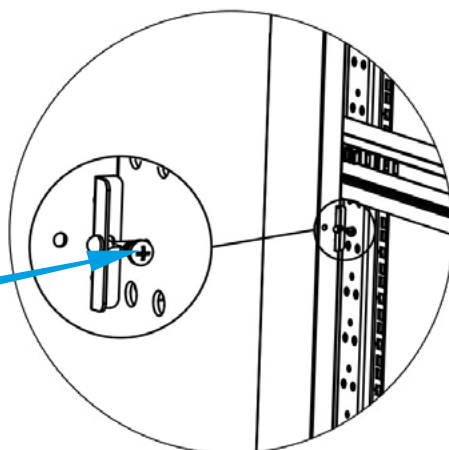

Step 11. Prepare and place the door spacers (item W) for the front door and rear panel (items A and B) in the appropriate places. Fit the side panels (item C) at the very end.









1. Instructions de montage





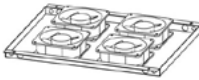

i **Veillez à suivre strictement les instructions de ce manuel.**





1.1 Préparatifs

Prévoyez suffisamment d'espace libre sur la surface où l'assemblage sera effectué. Retirez soigneusement tous les éléments de la boîte de transport. Les étapes de montage suivantes se basent sur le schéma fourni.

1.1.1. Tableau des accessoires

| Pièces de l'armoire | | | | |
|---------------------|-------------------------------|---|--------------------------------|--------------------|
| N° d'élément | Nom de l'élément | Dessin de l'élément | Nombre requis | Nombre dans le kit |
| Élément A | Porte avant vitrée |  | 1 pce. | 1 pce. |
| Élément B | Panneau arrière |  | 1 pce. | 1 pce. |
| Élément C | Panneaux latéraux |  | 2 pcs | 2 pcs |
| Élément D | Cadre |  | 2 pcs | 2 pcs |
| Élément E | Couvercle supérieur |  | 1 pce. | 1 pce. |
| Élément F | Couvercle inférieur |  | 1 pce. | 1 pce. |
| Élément G | Traverse |  | 15U~27U 4 pcs 32U~42U 6 pcs | |
| Élément H | Étagère pour ventilateur |  | 1 pce. | 1 pce. |
| Élément I | Rails de montage |  | 4 pcs | 4 pcs |
| Élément J | Capuchon du panneau supérieur |  | Plat 3 pcs Rainuré 4 pcs | |

| | | | | |
|-----------|----------------------------|--|---------------------------------|--------|
| Élément K | Pieds réglables |  | 4 pcs | 4 pcs |
| Élément L | Roues avec freins |  | 4 pcs | 4 pcs |
| Élément M | Butées de porte |  | 15U~27U 8 pcs 32U~42U 12 pcs | |
| Élément N | Serrure de porte avant |  | 1 pce. | 1 pce. |
| Élément O | Serrure de panneau arrière |  | 3 pcs | 3 pcs |
| Élément W | Entretoises de porte |  | 2 pcs | 4 pcs |

| Vis | | | | |
|--------------|---------------------------------|---|----------------|--------------------|
| N° d'élément | Nom de l'élément | Dessin de l'élément | Nombre requis | Nombre dans le kit |
| Élément Q | Vis Allen M8 |  | 16 pcs | 17 pcs |
| Élément R | Vis autotaraudeuses M5*10 |  | 15U~27U 36 pcs | 40 pcs |
| | | | 32U~42U 44 pcs | 50 pcs |
| Élément S | Vis autotaraudeuses M4*8 |  | 15U~27U 20 pcs | 23 pcs |
| | | | 32U~42U 26 pcs | 30 pcs |
| Élément T | Écrou cage M6 |  | 15U~27U 32 pcs | 35 pcs |
| | | | 32U~42U 48 pcs | 50 pcs |
| Élément U | Vis Allen M6x12 |  | 15U~27U 32 pcs | 35 pcs |
| | | | 32U~42U 48 pcs | 52 pcs |
| Élément V | Vis et écrou M6 supplémentaires |  | 20 pcs | 20 pcs |

2. Étapes de montage

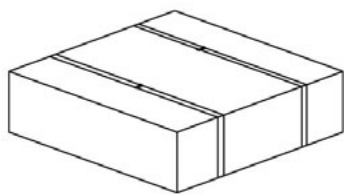

**COLIS SUPÉRIEUR ET
INFÉRIEUR 1/3**

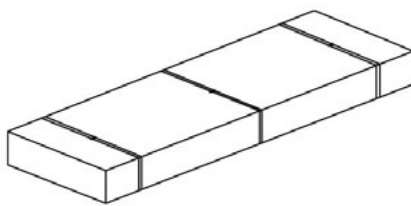

**PORTE AVANT, PANNEAU
ARRIÈRE ET PANNEAUX
LATÉRAUX 2/3**

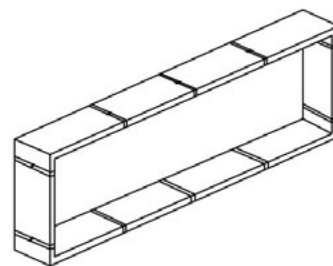

COLIS CADRE 3/3

Étape 1. Retirez la serrure de la porte avant (élément N), les serrures des panneaux latéraux et la serrure du panneau arrière (élément O) — les composants se trouvent dans le colis 1/3. Ensuite, retirez la porte avant vitrée (élément A), le panneau arrière (élément B) et les panneaux latéraux (élément C) du colis 2/3. À ce stade, commencez par installer les serrures sur les composants ci-dessus.



Étape 2. Déballez les éléments du cadre (élément J) du colis 3/3. Disposez ensuite les cadres parallèlement, avec les trous carrés orientés vers l'intérieur. Vous pouvez reconnaître la partie inférieure du cadre grâce à l'élément prévu pour la mise à la terre.

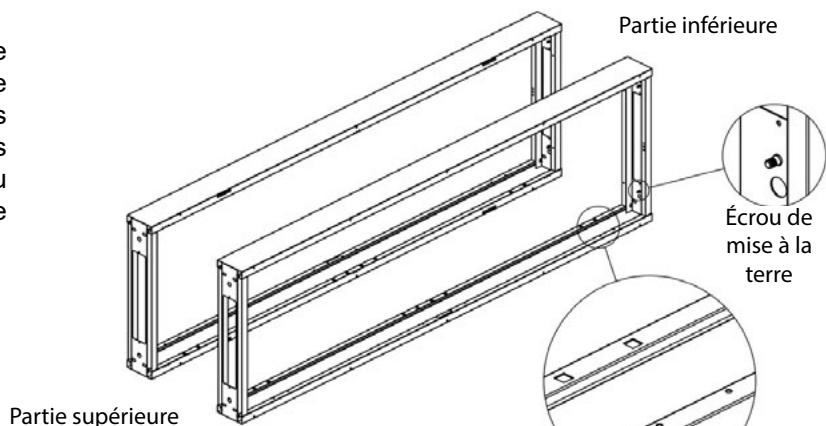

Étape 3. Montez le couvercle supérieur (élément E) sur la partie supérieure du cadre (élément D), puis utilisez une vis Allen M8 (élément Q) pour les assembler ensemble.

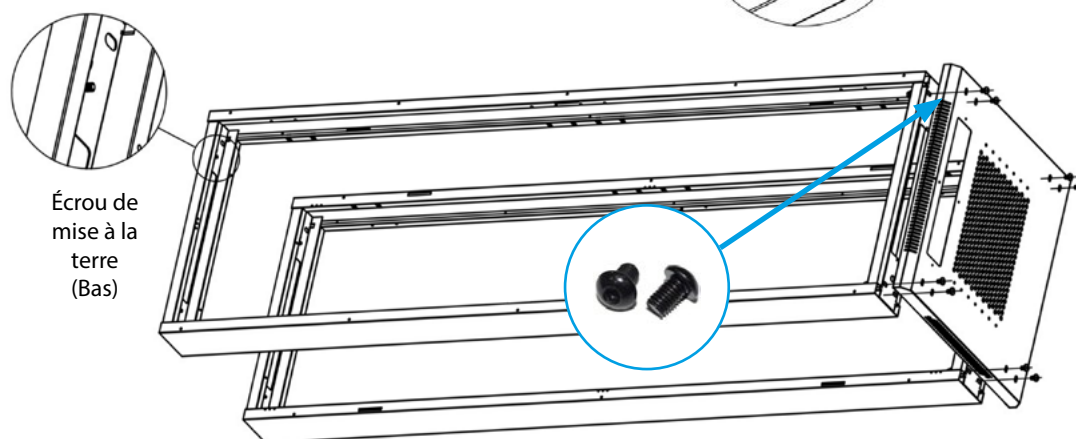

Étape 4. Montez le couvercle inférieur (élément F) sur la partie inférieure du cadre (élément D), puis utilisez un boulon Allen M8 (élément Q) pour les assembler.

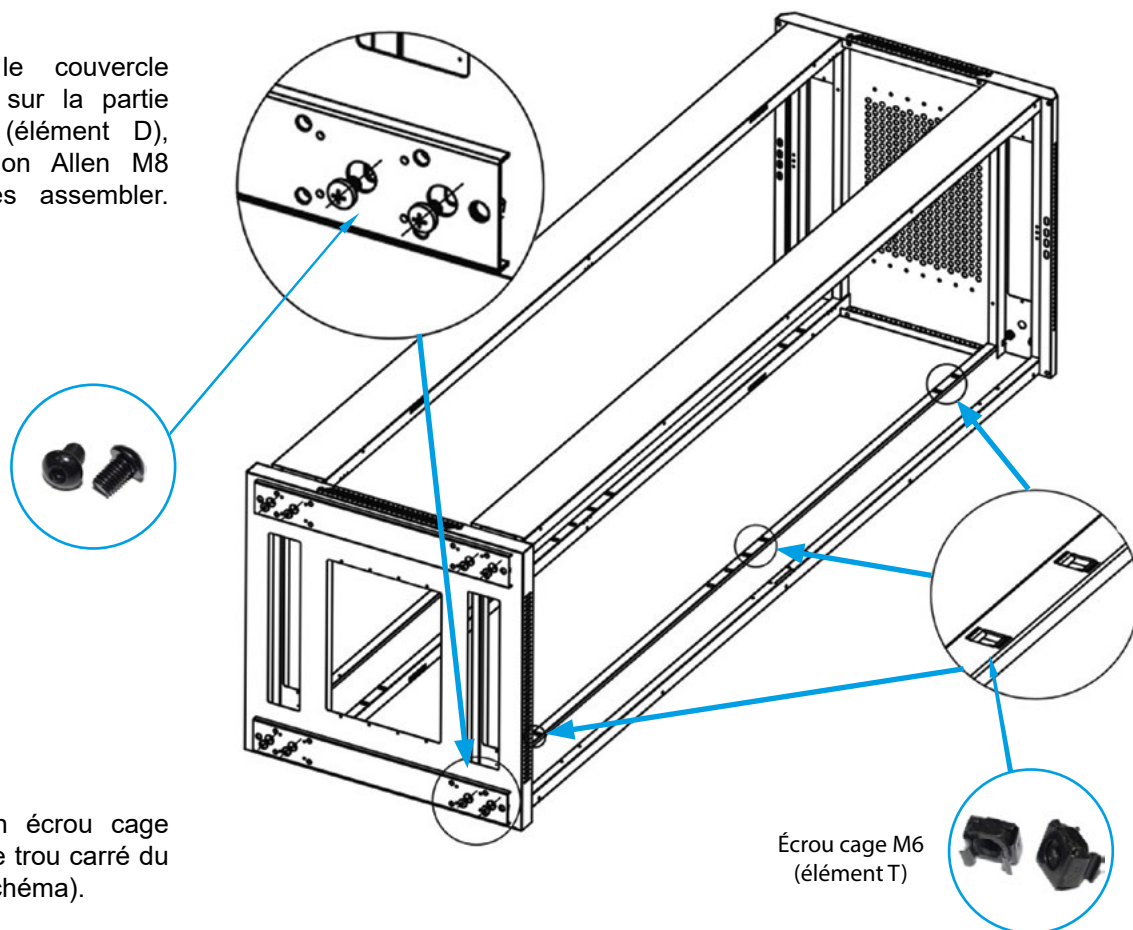

Étape 4a. Insérez un écrou cage M6 (élément T) dans le trou carré du cadre (indiqué sur le schéma).

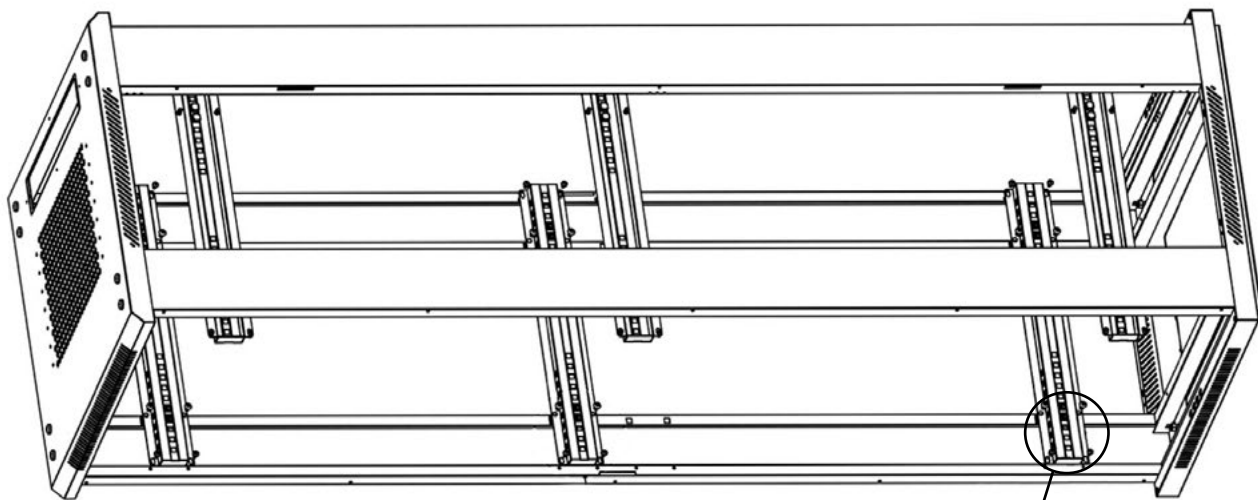

Boulon à tête Allen M6
(élément U)

Étape 5. Préparez les écrous cage M6 (élément T) et fixez-les sur la traverse (élément G), puis placez la traverse sur le cadre (élément D) en évitant le trou de verrouillage du cadre. Utilisez une vis Allen M6 (élément U) et une vis autotaraudeuse M5 (élément R) pour fixer la traverse.

Vis autotaraudeuse M5
(élément R)

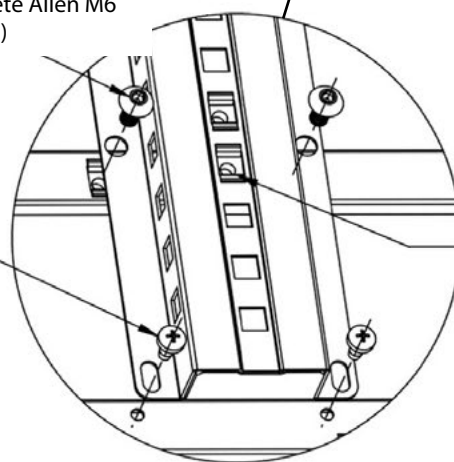

Écrou cage M6
(élément T)

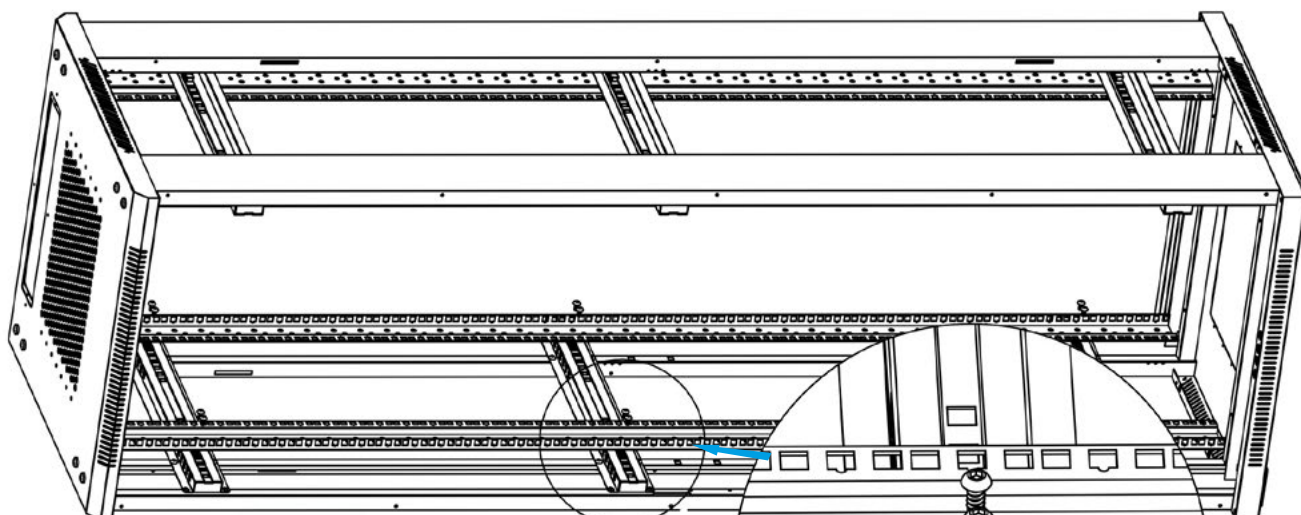

Étape 6. Préparez les vis de montage M6 (élément U). Utilisez-les pour fixer les rails de montage verticaux (élément I) aux traverses horizontales (élément G).



Boulon à tête Allen M6
(élément U)

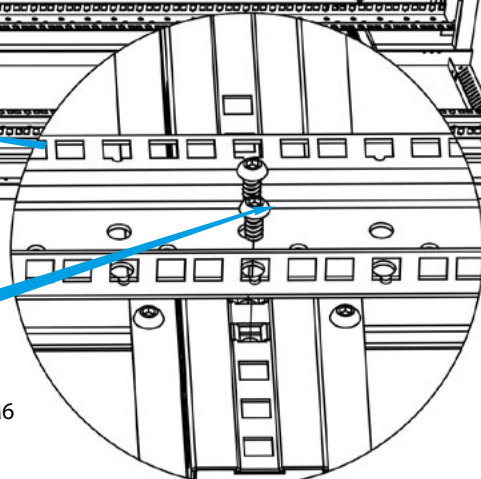

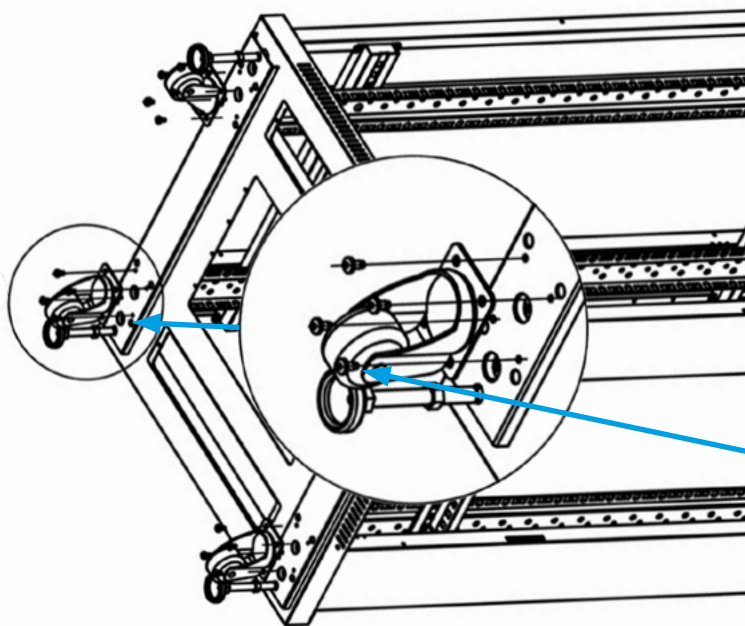

Étape 7. Préparez les vis autotaraudeuses M5 (élément R) afin de fixer les quatre roues avec freins (élément L) sur le couvercle inférieur (élément F). Ensuite, montez les pieds réglables (élément K) sur le couvercle inférieur.



Vis autotaraudeuse M5 (élément R)

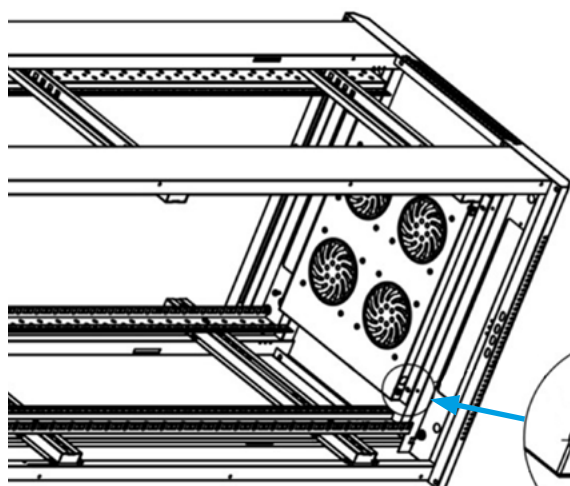

Étape 8. Préparez les vis autotaraudeuses M5 (élément R), puis utilisez-les pour fixer l'étagère pour ventilateur (élément H) au cadre RACK (élément D).



Vis autotaraudeuse M5 (élément R)

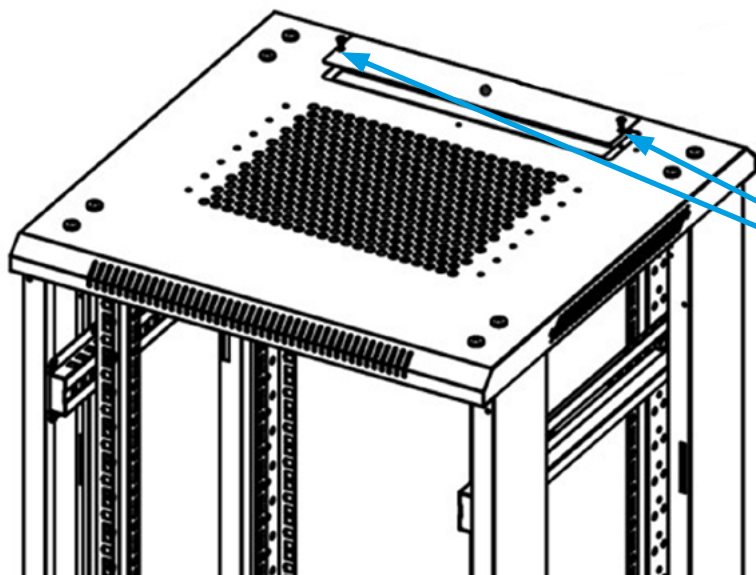

Étape 9. Préparez et utilisez une vis autotaraudeuse M4 (élément S) pour fixer le capuchon du panneau supérieur (élément J).



Vis autotaraudeuse M4 (élément S)

Étape 10. Préparez et utilisez des vis autotaraudeuses M4 (élément S) pour fixer les butées de porte (élément M). Pour les tailles 15U~27U (8 pcs), 32U~47U (12 pcs).



Vis autotaraudeuse M4
(élément S)

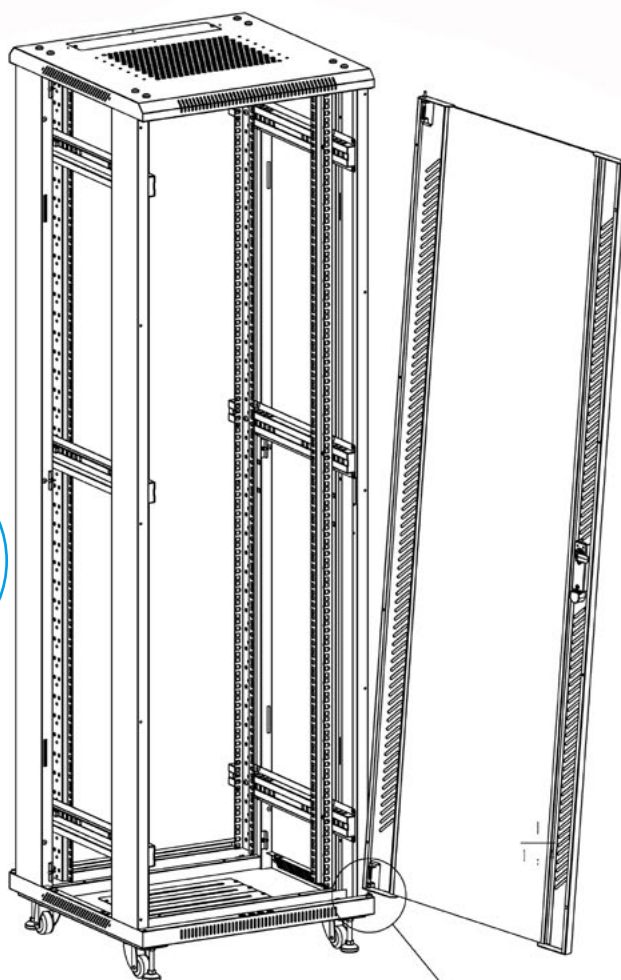
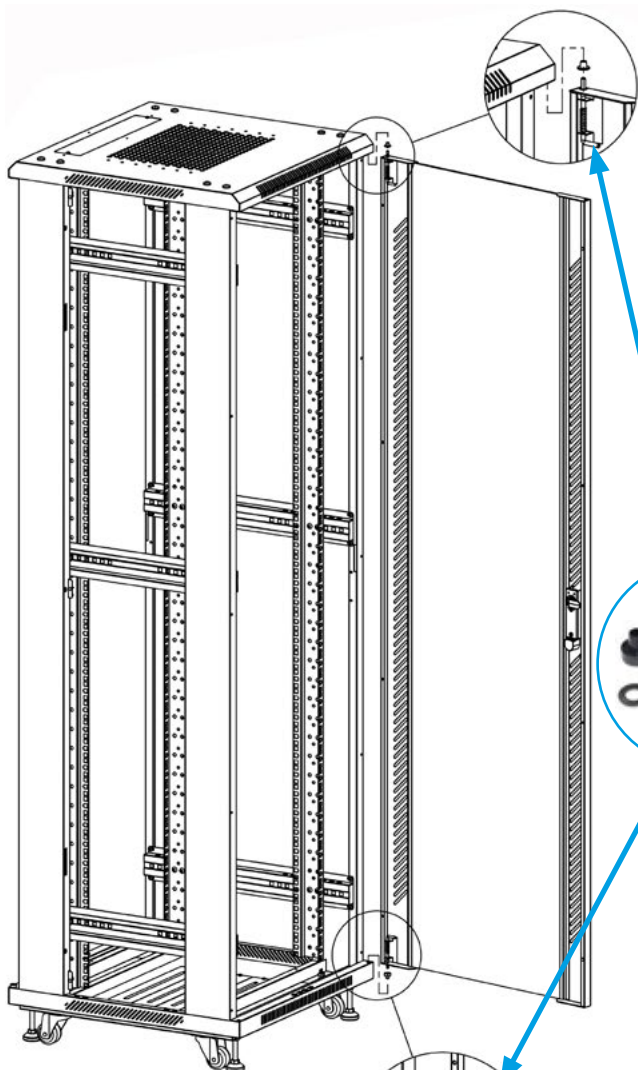
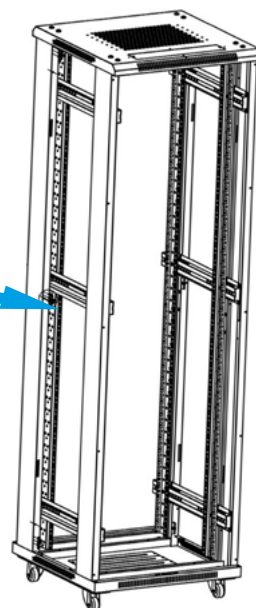
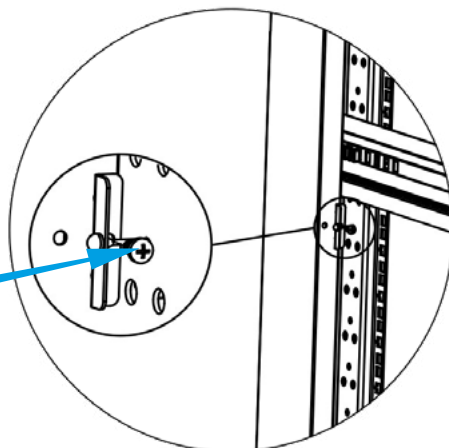

Étape 11. Préparez et placez les entretoises de porte (élément W) pour la porte avant et le panneau arrière (éléments A et B) aux emplacements appropriés. Installez les panneaux latéraux (élément C) tout à la fin.











1. Instrucciones de montaje





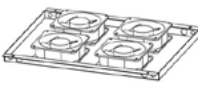

i **Asegúrese de seguir estrictamente las instrucciones de este manual.**

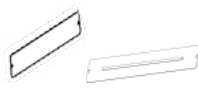
1.1 Preparación

Prepare el espacio libre adecuado en la superficie donde se realizará el montaje. Retire cuidadosamente todos los elementos de la caja de transporte. Las siguientes instrucciones de montaje se basarán en el diagrama proporcionado

1.1.1. Tabla de accesorios

| Piezas del armario | | | | |
|--------------------|---------------------------|---|----------------------------------|-------------------------|
| N.º de artículo | Nombre del artículo | Dibujo del artículo | Cantidad requerida | Cantidad en el conjunto |
| Artículo A | Puerta frontal de vidrio |  | 1 ud. | 1 ud. |
| Artículo B | Panel trasero |  | 1 ud. | 1 ud. |
| Artículo C | Paneles laterales |  | 2 uds. | 2 uds. |
| Artículo D | Marco |  | 2 uds. | 2 uds. |
| Artículo E | Tapa superior |  | 1 ud. | 1 ud. |
| Artículo F | Tapa inferior |  | 1 ud. | 1 ud. |
| Artículo G | Travesía |  | 15U~27U 4 uds. 32U~42U 6 uds. | |
| Artículo H | Bandeja para ventiladores |  | 1 ud. | 1 ud. |
| Artículo I | Rieles de montaje |  | 4 uds. | 4 uds. |
| Artículo J | Tapón del panel superior |  | Plano 3 uds. Ranurado 4 uds. | |

| | | | | |
|------------|--------------------------------|--|-----------------------------------|--------|
| Artículo K | Patas regulables |  | 4 uds. | 4 uds. |
| Artículo L | Ruedas con freno |  | 4 uds. | 4 uds. |
| Artículo M | Topes de puerta |  | 15U~27U 8 uds. 32U~42U 12 uds. | |
| Artículo N | Cerradura de la puerta frontal |  | 1 ud. | 1 ud. |
| Artículo O | Cerradura del panel trasero |  | 3 uds. | 3 uds. |
| Artículo W | Distanciadores de puerta |  | 2 uds. | 4 uds. |

| Tornillos | | | | |
|-----------------|----------------------------------|---|--------------------|-------------------------|
| N.º de artículo | Nombre del artículo | Dibujo del artículo | Cantidad requerida | Cantidad en el conjunto |
| Artículo Q | Tornillo Allen M8 |  | 16 uds. | 17 uds. |
| Artículo R | Tornillos autorroscantes M5*10 |  | 15U~27U 36 uds. | 40 uds. |
| | | | 32U~42U 44 uds. | 50 uds. |
| Artículo S | Tornillos autorroscantes M4*8 |  | 15U~27U 20 uds. | 23 uds. |
| | | | 32U~42U 26 uds. | 30 uds. |
| Artículo T | Tuerca de jaula M6 |  | 15U~27U 32 uds. | 35 uds. |
| | | | 32U~42U 48 uds. | 50 uds. |
| Artículo U | Tornillo Allen M6x12 |  | 15U~27U 32 uds. | 35 uds. |
| | | | 32U~42U 48 uds. | 52 uds. |
| Artículo V | Tornillo y tuerca adicionales M6 |  | 20 uds. | 20 uds. |

2. Etapas de montaje

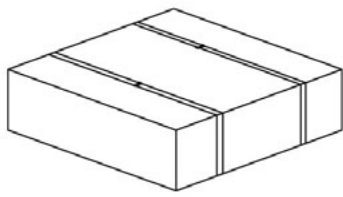

**PAQUETE SUPERIOR E
INFERIOR 1/3**

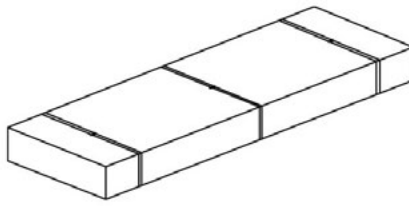

**PUERTA FRONTAL, PANEL
TRASERO Y PANELES
LATERALES 2/3**

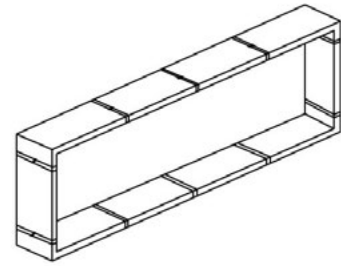

PAQUETE DEL MARCO 3/3

Paso 1. Retire la cerradura de la puerta frontal (elemento N), las cerraduras de los paneles laterales y la cerradura del panel trasero (elemento O); los componentes están en el paquete 1/3. Luego retire la puerta frontal de vidrio (elemento A), el panel trasero (elemento B) y los paneles laterales (elemento C) del paquete 2/3. En esta etapa comenzamos instalando las cerraduras en los componentes anteriores.

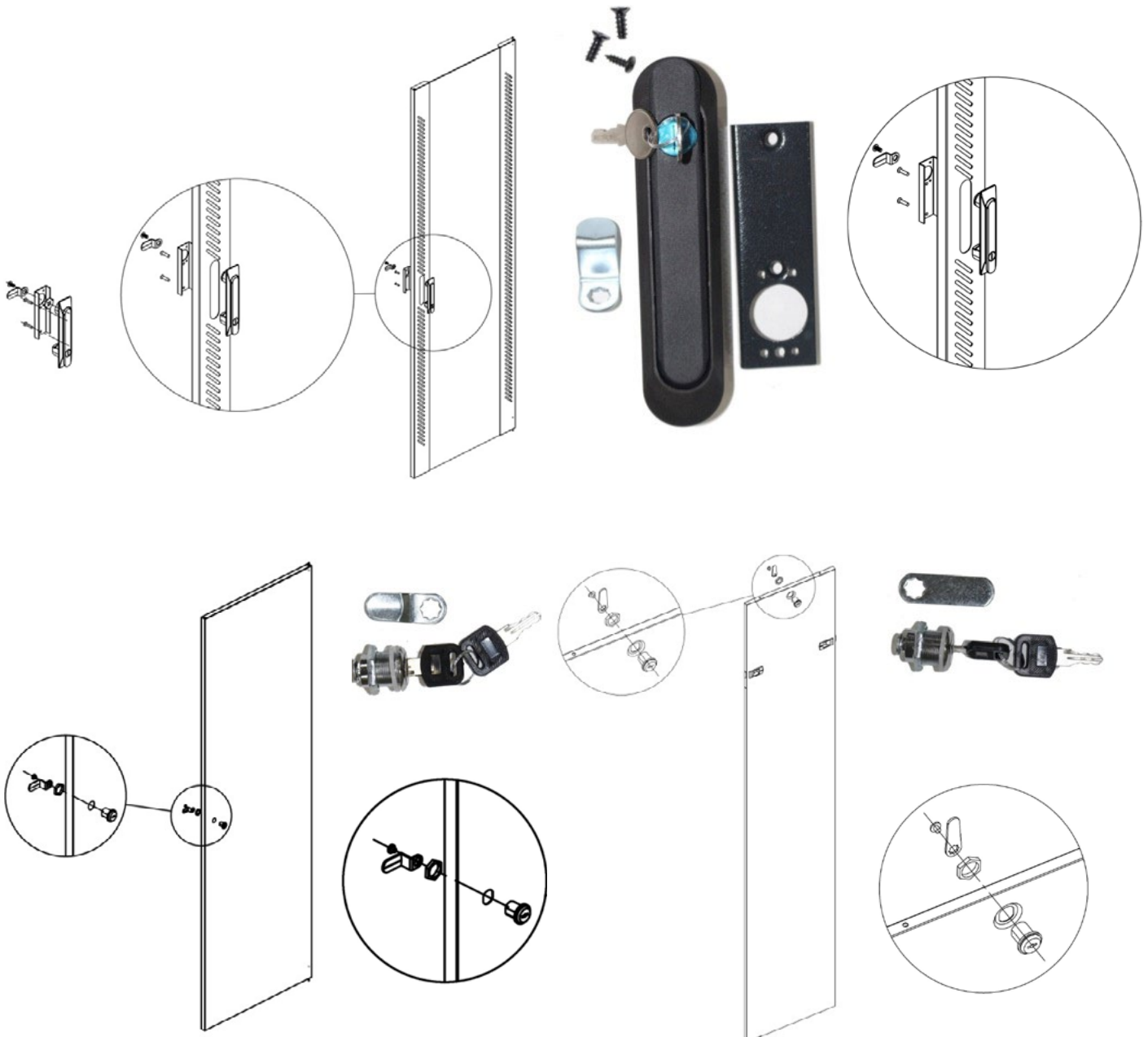

Paso 2. Desembale las piezas del marco (elemento J) del paquete 3/3. Luego coloque los marcos paralelos entre sí, con los orificios cuadrados orientados hacia el interior. Puede reconocer la parte inferior del marco por el elemento para instalar la puesta a tierra.

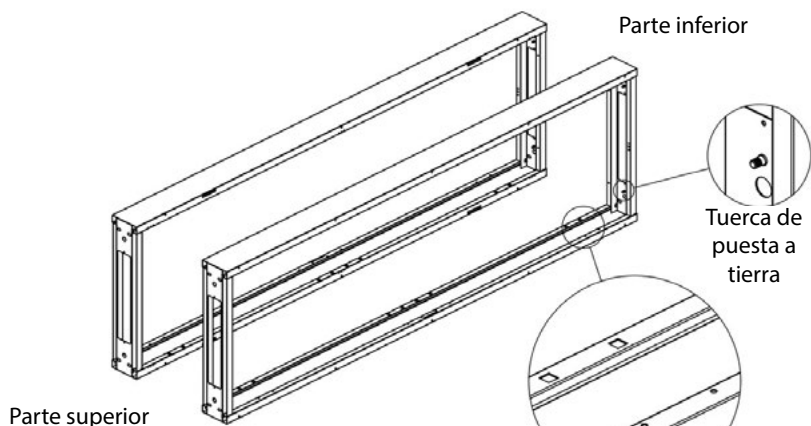

Paso 3. Coloque la tapa superior (elemento E) en la parte superior del marco (elemento D) y luego utilice un tornillo Allen M8 (elemento Q) para montarlas juntas.

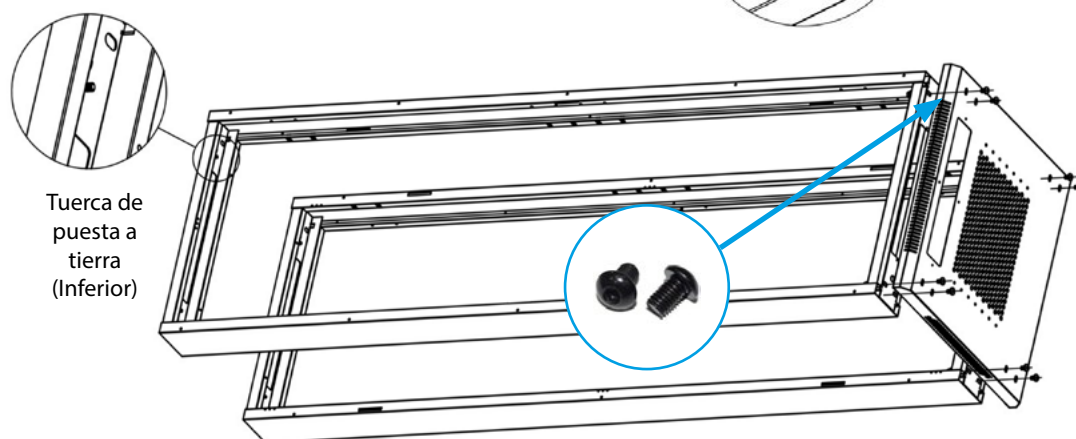

Paso 4. Coloque la tapa inferior (elemento F) en la parte inferior del marco (elemento D) y luego utilice un perno Allen M8 (elemento Q) para unirlos.

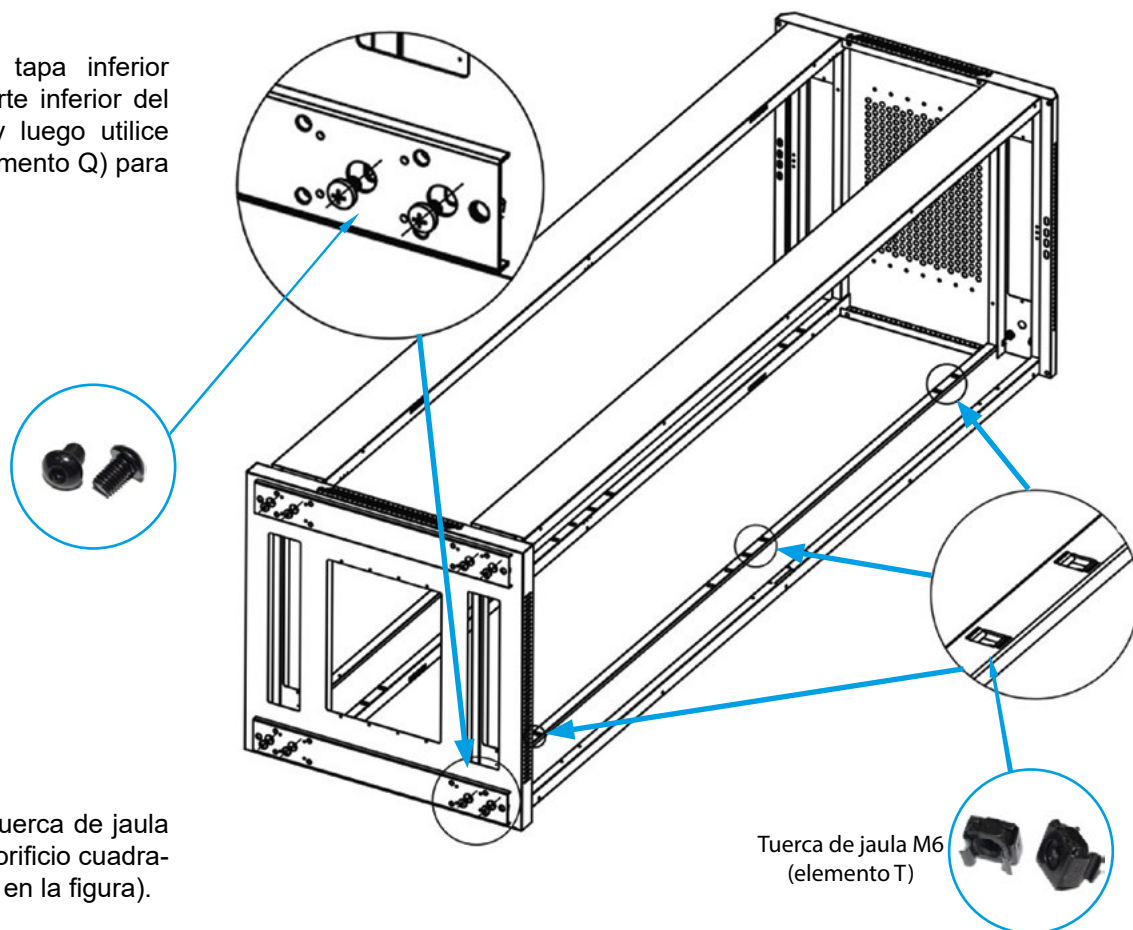

Paso 4a. Inserte una tuerca de jaula M6 (elemento T) en el orificio cuadrado del marco (indicado en la figura).

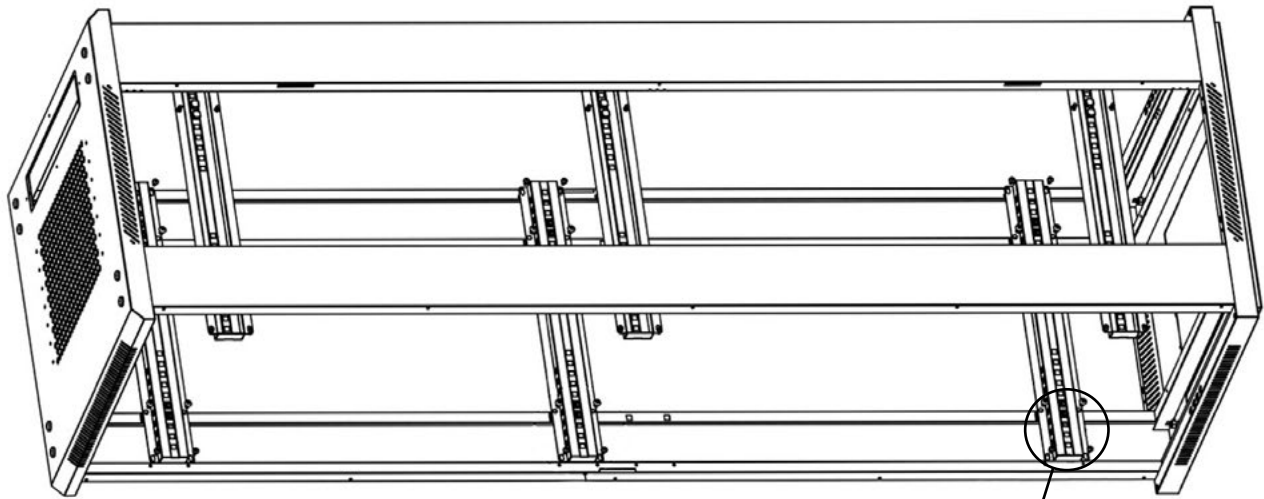

Perno Allen M6
(elemento U)

Paso 5. Prepare las tuercas de jaula M6 (elemento T) y fíjelas en la travesía (elemento G); a continuación, coloque la travesía en el marco (elemento D) evitando el orificio de bloqueo del marco. Use un tornillo Allen M6 (elemento U) y un tornillo autorroscante M5 (elemento R) para fijar la travesía.

Tornillo autorroscante
M5 (elemento R)

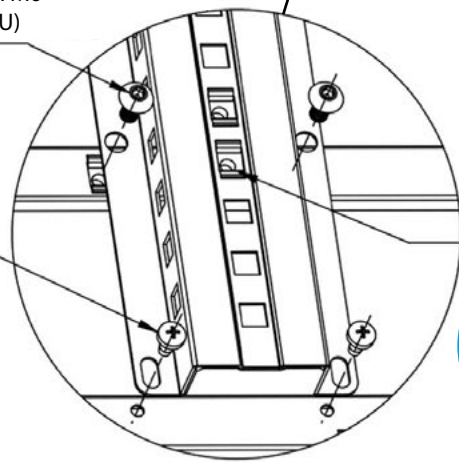

Tuerca de jaula M6
(elemento T)

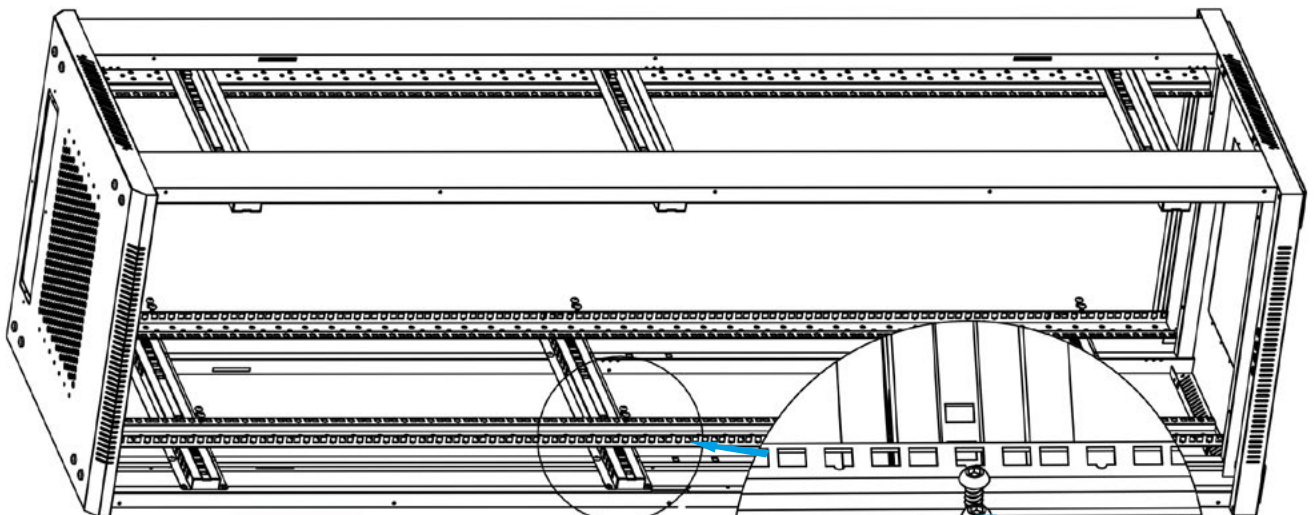

Perno Allen M6
(elemento U)

Paso 6. Prepare los tornillos de montaje M6 (elemento U). Utilice los tornillos para fijar los rieles de montaje verticales (elemento I) a las travesías horizontales (elemento G).

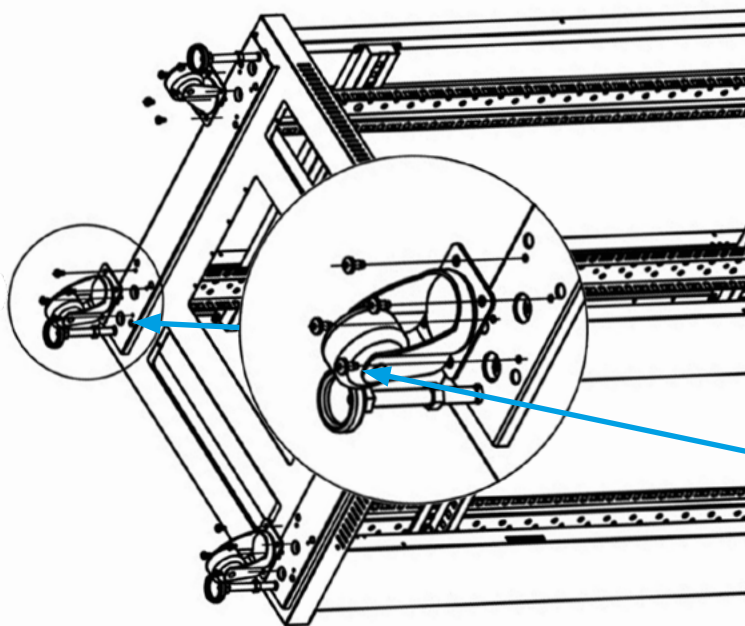

Paso 7. Prepare los tornillos autorroscantes M5 (elemento R) para fijar las cuatro ruedas con freno (elemento L) en la tapa inferior (elemento F). Luego monte las patas regulables (elemento K) en la tapa inferior.



Tornillo autorroscante M5 (elemento R)

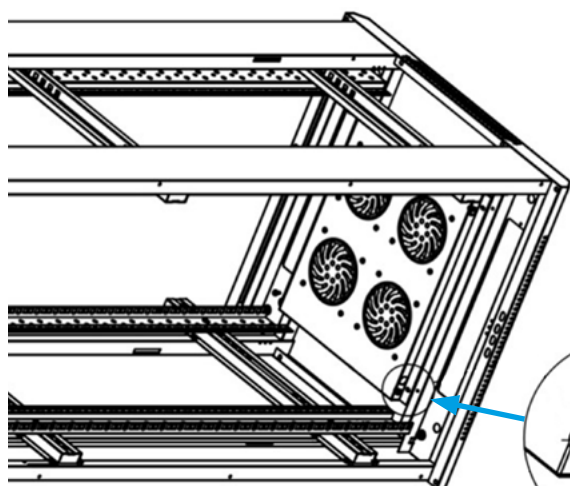

Paso 8. Prepare los tornillos autorroscantes M5 (elemento R) y úselos para fijar la bandeja para ventiladores (elemento H) al marco RACK (elemento D).



Tornillo autorroscante M5 (elemento R)

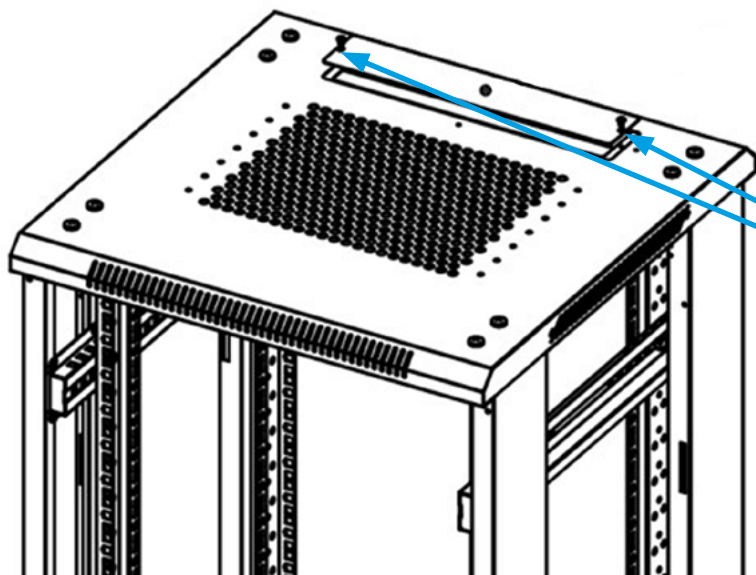

Paso 9. Prepare y utilice un tornillo autorroscante M4 (elemento S) para fijar el tapón del panel superior (elemento J).



Tornillo autorroscante M4 (elemento S)

Paso 10. Prepare y utilice los tornillos autorroscantes M4 (elemento S) para fijar los topos de puerta (elemento M). Para tamaños 15U~27U (8 uds.), 32U~47U (12 uds.).



Tornillo autorroscante M4 (elemento S)

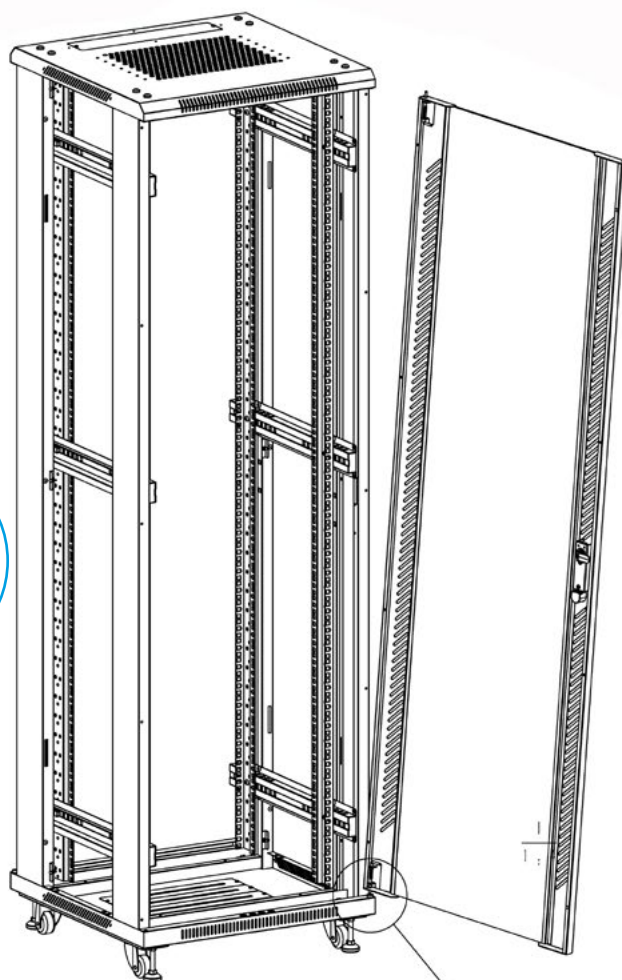
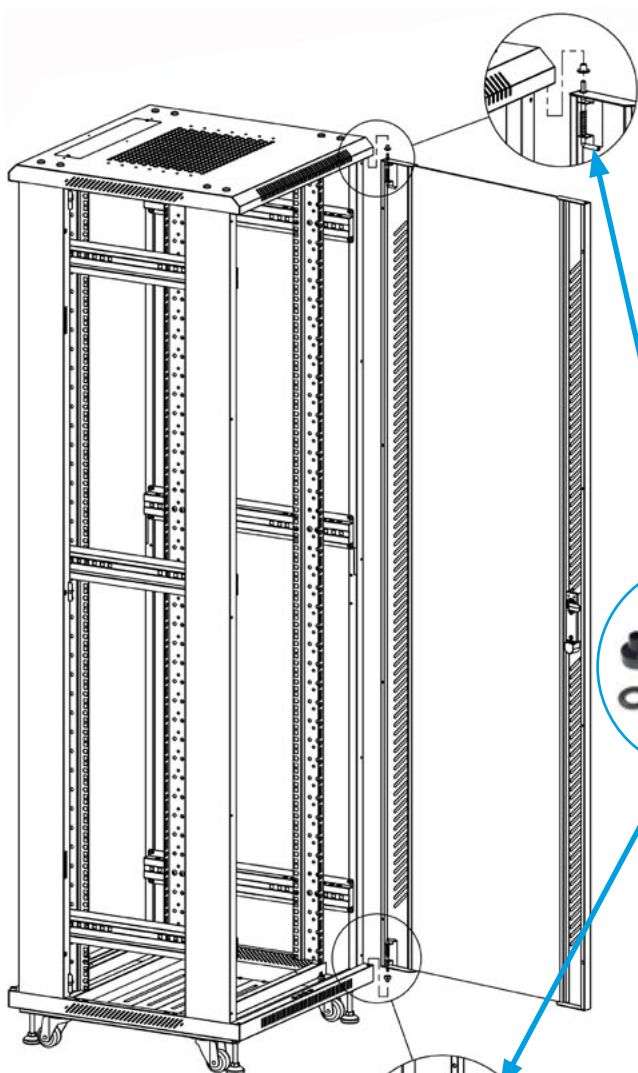
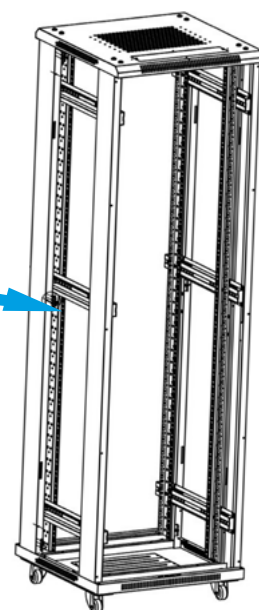
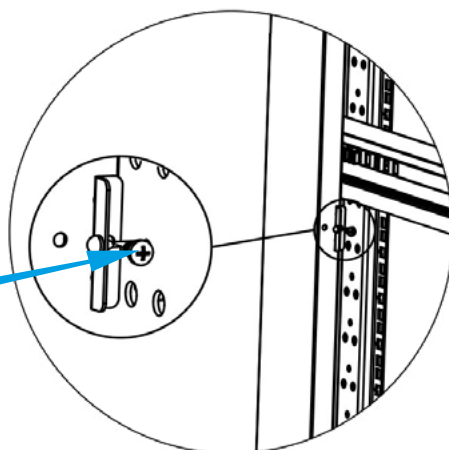

Paso 11. Prepare y coloque los distanciadores de puerta (elemento W) para la puerta frontal y el panel trasero (elementos A y B) en los lugares correspondientes. Monte los paneles laterales (elemento C) al final.



1. Instruções de montagem







i *Certifique-se de seguir rigorosamente as instruções deste manual.*

1.1 Preparação

Prepare espaço livre suficiente na superfície onde a montagem será realizada. Retire cuidadosamente todos os elementos da caixa de transporte. As instruções de montagem seguintes baseiam-se no diagrama fornecido

1.1.1. Tabela de acessórios

| Peças do armário | | | | |
|------------------|--------------------------|-----------------|--------------------------------|------------------------|
| Nº do item | Nome do item | Desenho do item | Quantidade necessária | Quantidade no conjunto |
| Item A | Porta frontal de vidro | | 1 un. | 1 un. |
| Item B | Painel traseiro | | 1 un. | 1 un. |
| Item C | Painéis laterais | | 2 un. | 2 un. |
| Item D | Estrutura | | 2 un. | 2 un. |
| Item E | Tampa superior | | 1 un. | 1 un. |
| Item F | Tampa inferior | | 1 un. | 1 un. |
| Item G | Travessa | | 15U~27U 4 un. 32U~42U 6 un. | |
| Item H | Prateleira de ventoinhas | | 1 un. | 1 un. |
| Item I | Trilhos de montagem | | 4 un. | 4 un. |
| Item J | Tampa do painel superior | | Plano 3 un. Ranhurado 4 un. | |

| | | | | |
|--------|------------------------------|--|---------------------------------|-------|
| Item K | Pés ajustáveis |  | 4 un. | 4 un. |
| Item L | Rodas com travão |  | 4 un. | 4 un. |
| Item M | Batentes de porta |  | 15U~27U 8 un. 32U~42U 12 un. | |
| Item N | Fechadura da porta frontal |  | 1 un. | 1 un. |
| Item O | Fechadura do painel traseiro |  | 3 un. | 3 un. |
| Item W | Espaçadores de porta |  | 2 un. | 4 un. |

| Parafusos | | | | |
|------------|--------------------------------|---|-----------------------|------------------------|
| Nº do item | Nome do item | Desenho do item | Quantidade necessária | Quantidade no conjunto |
| Item Q | Parafuso Allen M8 |  | 16 un. | 17 un. |
| Item R | Parafusos auto-roscantes M5*10 |  | 15U~27U 36 un. | 40 un. |
| | | | 32U~42U 44 un. | 50 un. |
| Item S | Parafusos auto-roscantes M4*8 |  | 15U~27U 20 un. | 23 un. |
| | | | 32U~42U 26 un. | 30 un. |
| Item T | Porca de gaiola M6 |  | 15U~27U 32 un. | 35 un. |
| | | | 32U~42U 48 un. | 50 un. |
| Item U | Parafuso Allen M6x12 |  | 15U~27U 32 un. | 35 un. |
| | | | 32U~42U 48 un. | 52 un. |
| Item V | Parafuso e porca adicionais M6 |  | 20 un. | 20 un. |

2. Etapas de montagem

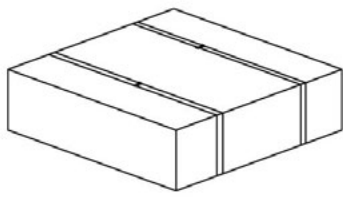

PACOTE SUPERIOR E INFERIOR 1/3

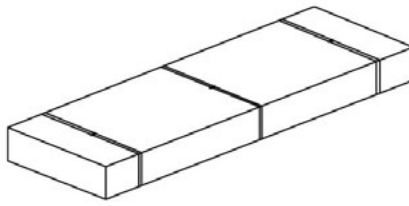

PORTA FRONTAL, PAINEL TRASEIRO E PAINÉIS LATERAIS 2/3

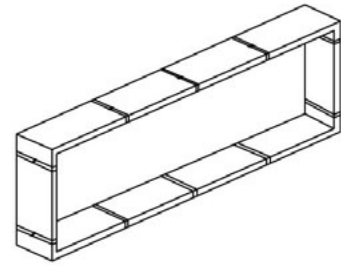

PACOTE DA ESTRUTURA 3/3

Passo 1. Remova a fechadura da porta frontal (item N), as fechaduras dos painéis laterais e a fechadura do painel traseiro (item O); os componentes estão no pacote 1/3. Em seguida, remova a porta frontal de vidro (item A), o painel traseiro (item B) e os painéis laterais (item C) do pacote 2/3. Nesta fase, começamos por instalar as fechaduras nos componentes acima.



Passo 2. Desembale as partes da estrutura (item J) do pacote 3/3. Em seguida, disponha as estruturas paralelamente umas às outras, com os orifícios quadrados voltados para o interior. Pode reconhecer a parte inferior da estrutura pelo elemento para instalar o aterramento.

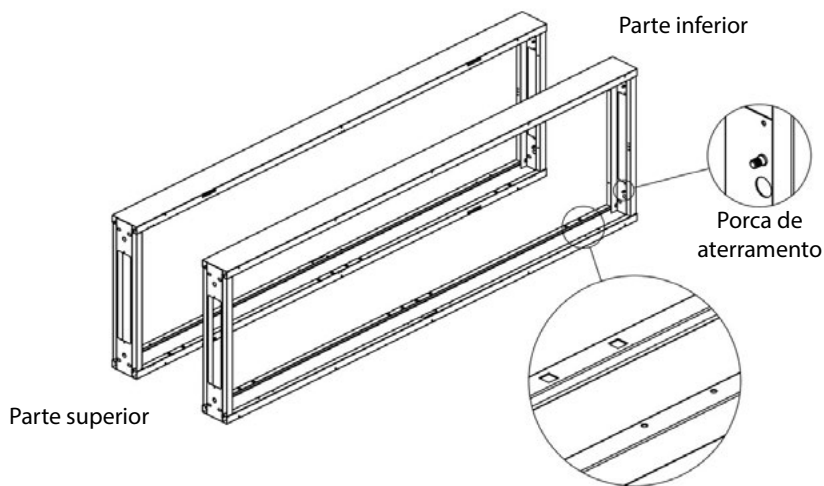

Passo 3. Encaixe a tampa superior (item E) na parte superior da estrutura (item D) e, em seguida, use um parafuso Allen M8 (item R) para montá-las juntas.

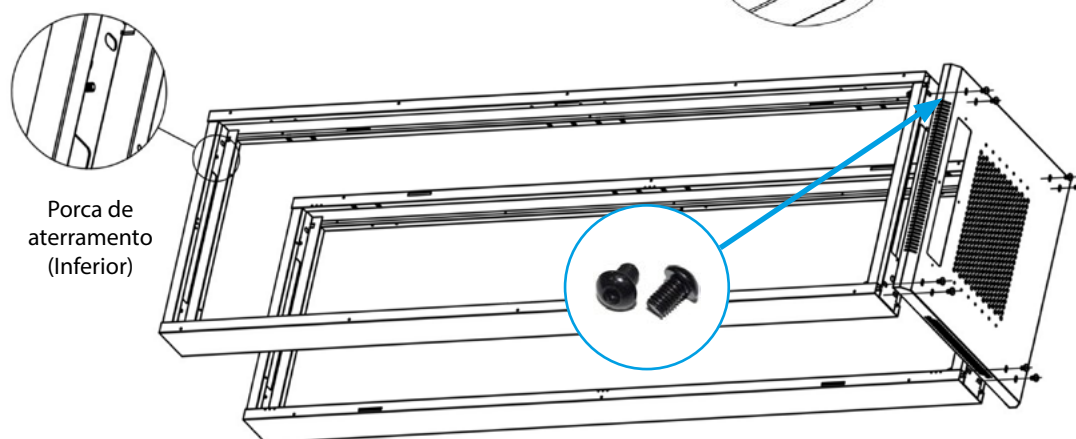

Passo 4. Encaixe a tampa inferior (item F) na parte inferior da estrutura (item D) e, em seguida, use um parafuso Allen M8 (item Q) para uni-las.

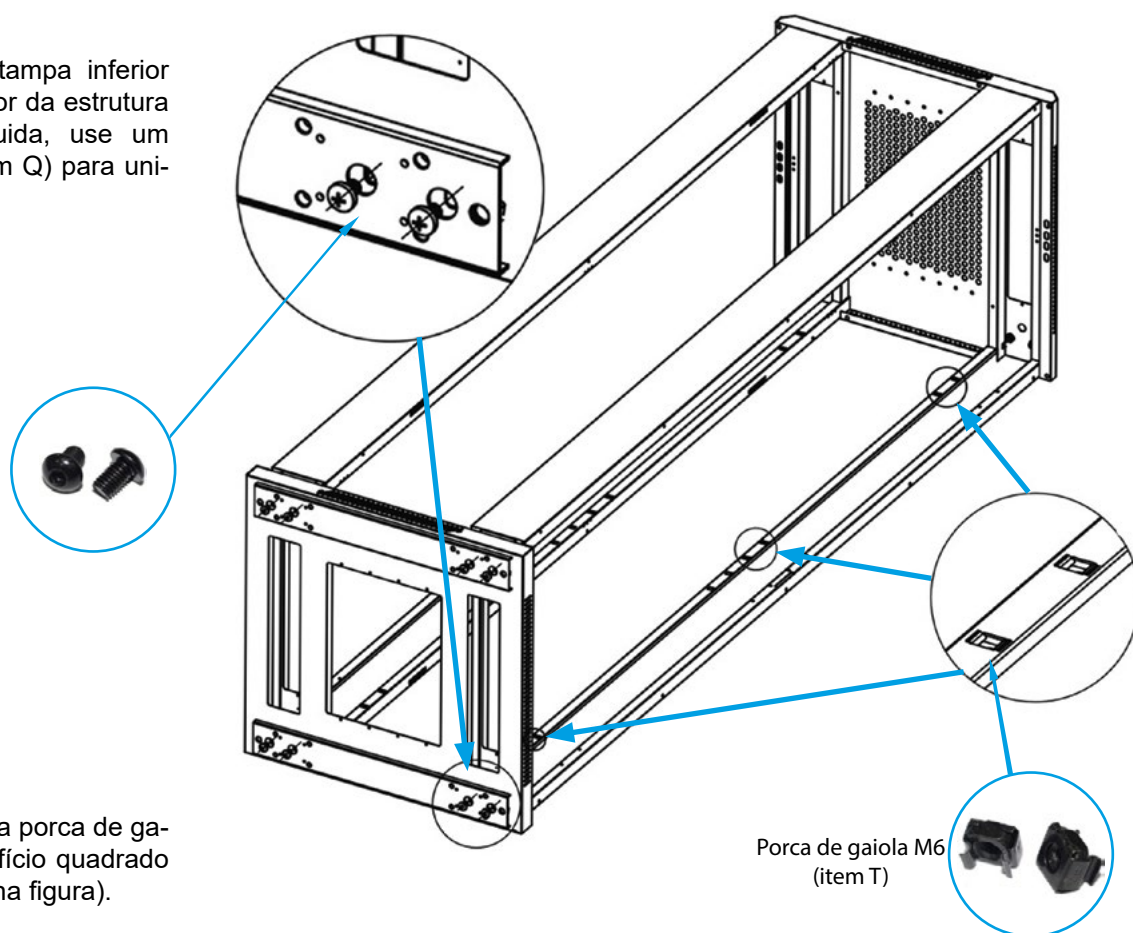

Passo 4a. Encaixe uma porca de gaiola M6 (item T) no orifício quadrado da estrutura (indicado na figura).

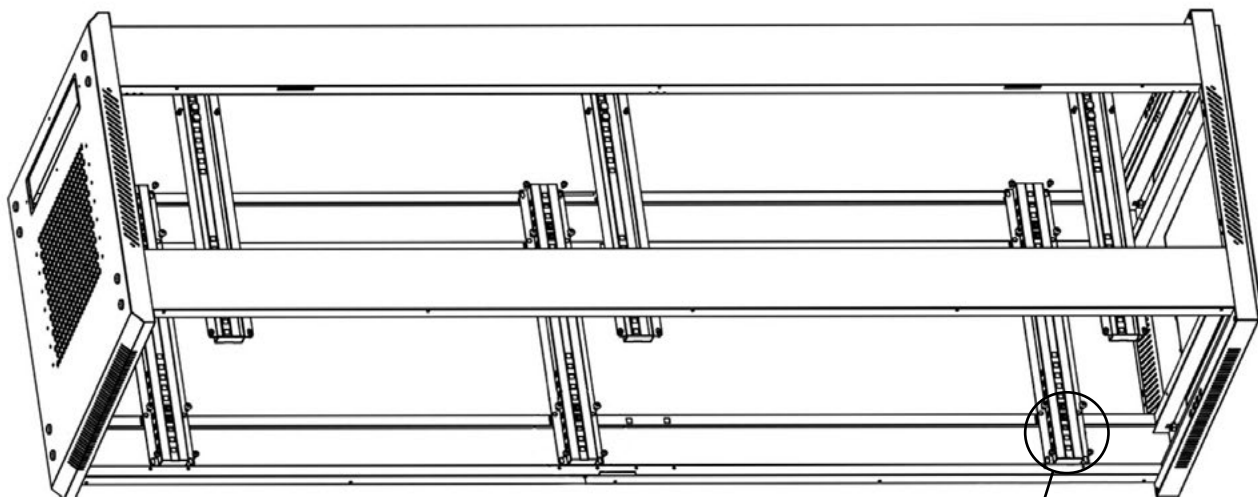

Parafuso Allen M6
(item U)

Passo 5. Prepare as porcas de gaiola M6 (item T) e fixe-as na travessa (item G); em seguida, coloque a travessa na estrutura (item D) evitando o orifício de bloqueio na estrutura. Utilize um parafuso Allen M6 (item U) e um parafuso auto-roscante M5 (item R) para fixar a travessa.

Parafuso auto-roscante
M5 (item R)

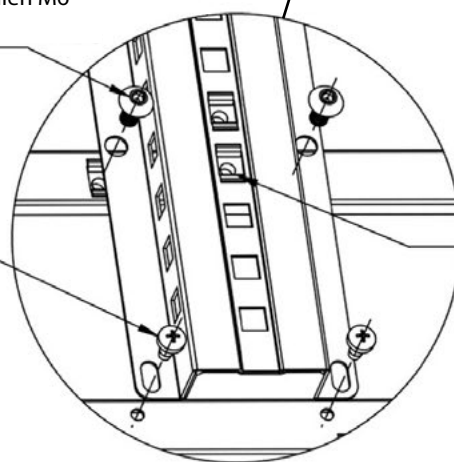

Porca de
gaiola M6
(item T)

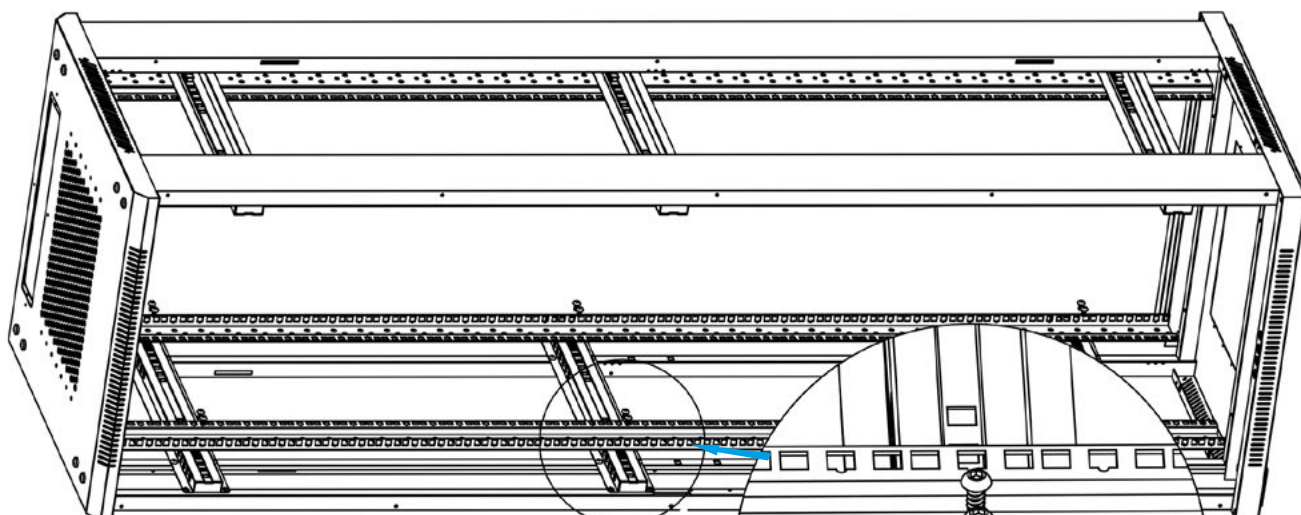

Parafuso Allen M6
(item U)

Passo 6. Prepare os parafusos de montagem M6 (item U). Utilize os parafusos para fixar os trilhos de montagem verticais (item I) às travessas horizontais (item G).

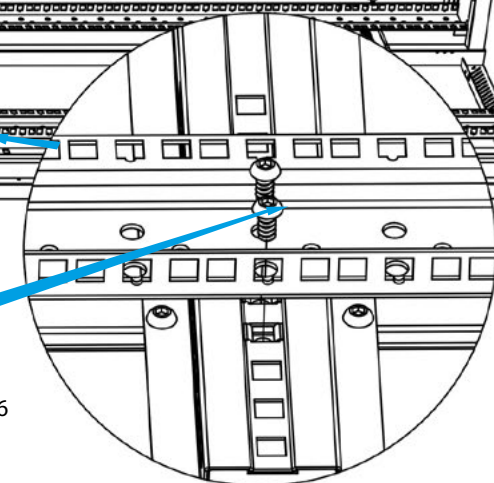

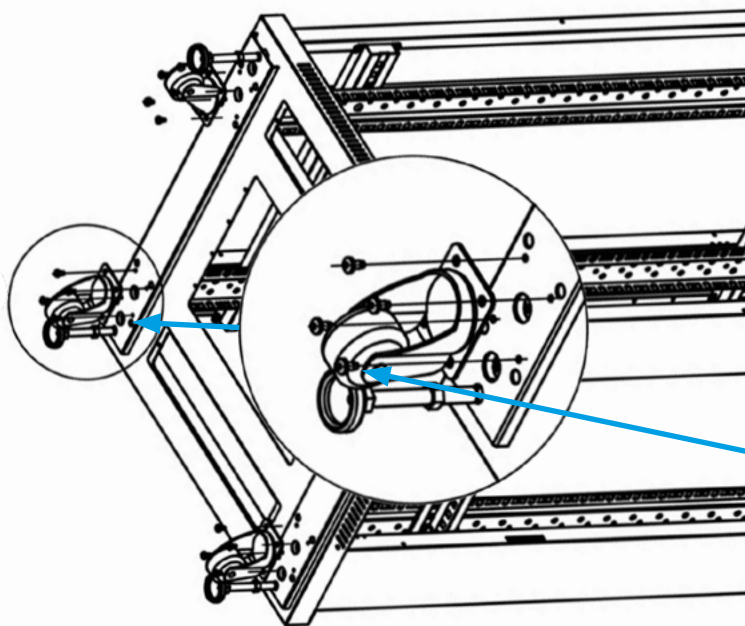

Passo 7. Prepare os parafusos auto-roscentes M5 (item R) para fixar as quatro rodas com travão (item L) na tampa inferior (item F). Em seguida, monte os pés ajustáveis (item K) na tampa inferior.



Parafuso auto-roscante M5 (item R)

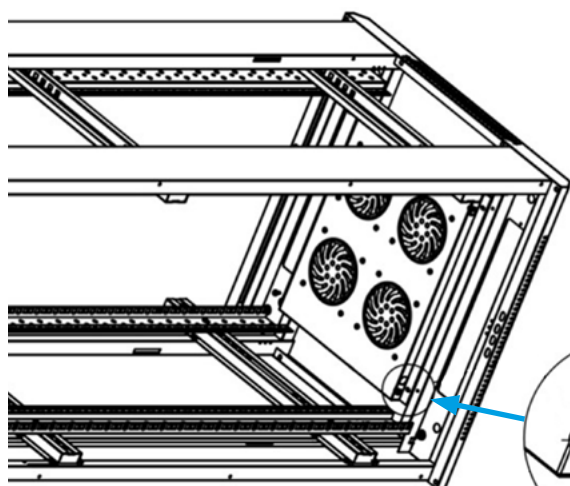

Passo 8. Prepare os parafusos auto-roscentes M5 (item R) e utilize-os para fixar a prateleira de ventoinhas (item H) à estrutura RACK (item D).



Parafuso auto-roscante M5 (item R)

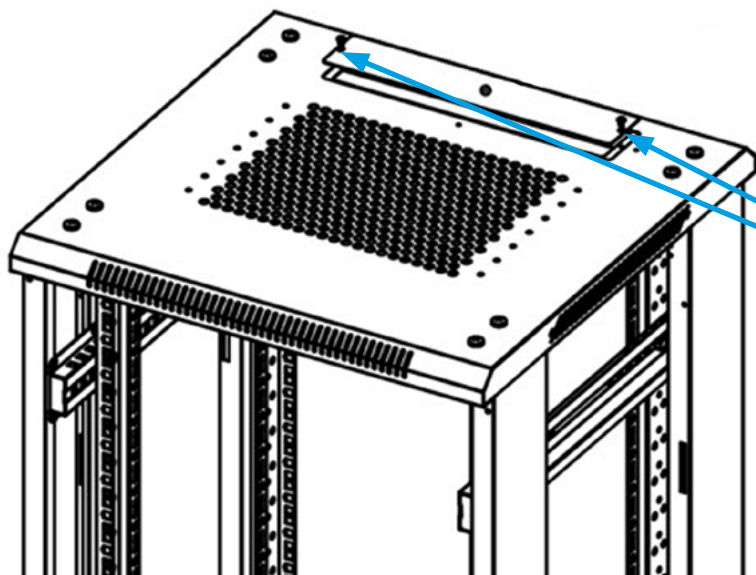

Passo 9. Prepare e utilize um parafuso auto-roscante M4 (item S) para fixar a tampa do painel superior (item J).



Parafuso auto-roscante M4 (item S)

Passo 10. Prepare e utilize os parafusos auto-roscantes M4 (item S) para fixar os batentes de porta (item M). Para tamanhos 15U~27U (8 un.), 32U~47U (12 un.).



Parafuso auto-roscante
M4 (item S)

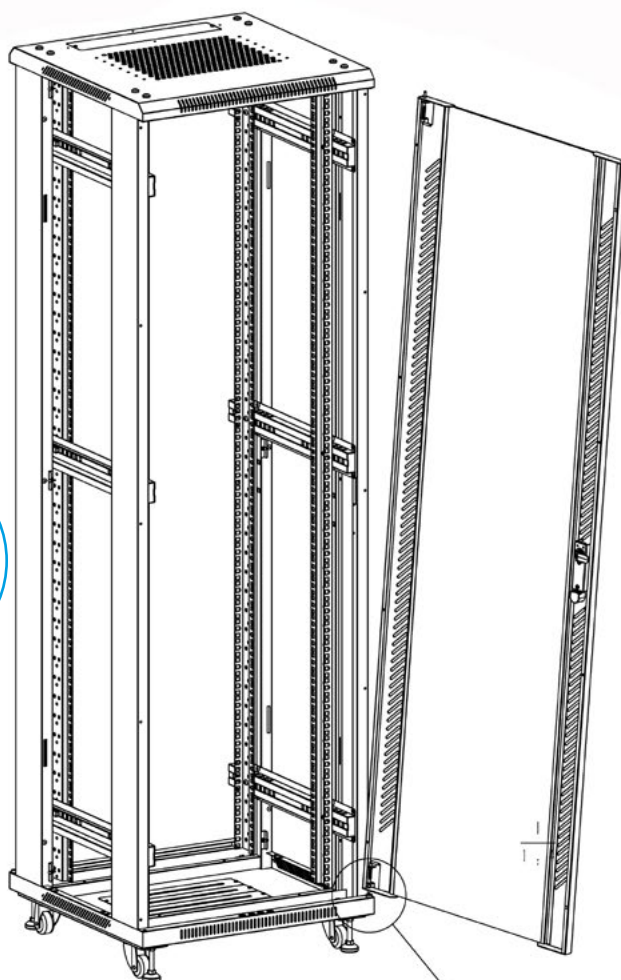
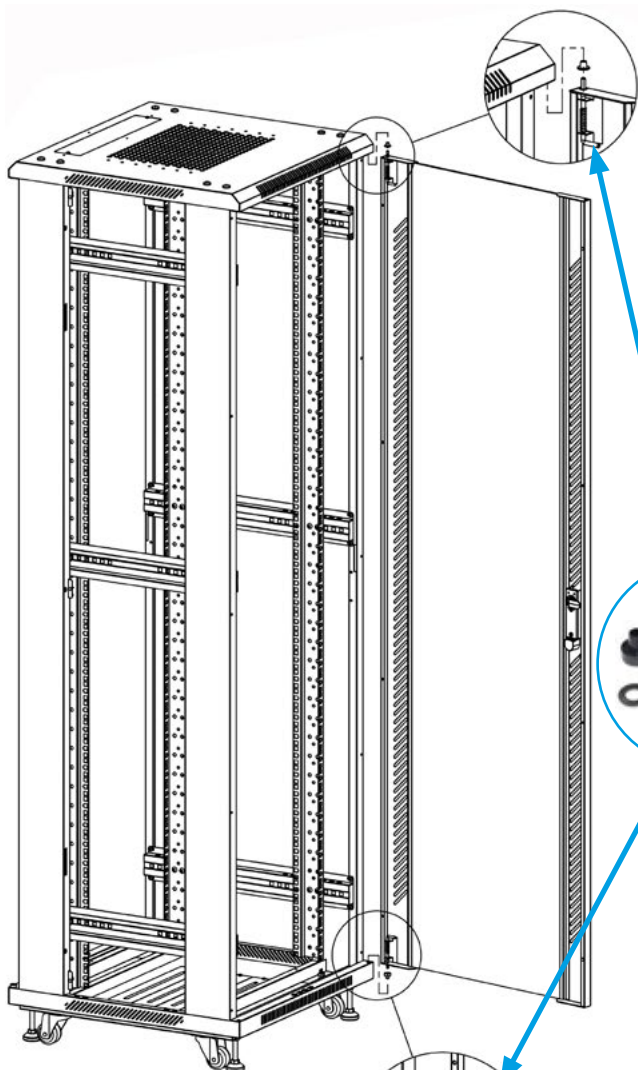
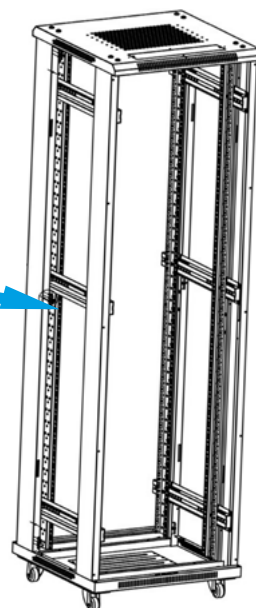
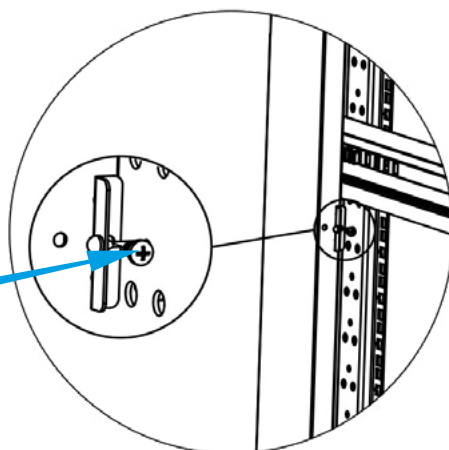

Passo 11. Prepare e coloque os espaçadores de porta (item W) para a porta frontal e o painel traseiro (itens A e B) nos locais adequados. Monte os painéis laterais (item C) apenas no final.











1. Montageanleitung





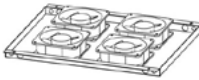

i **Befolgen Sie die Anweisungen in diesem Handbuch unbedingt genau.**





1.1 Vorbereitung

Sorgen Sie für ausreichend freie Fläche auf der Oberfläche, auf der die Montage stattfinden wird. Entfernen Sie alle Elemente vorsichtig aus der Transportbox. Die weiteren Montageanweisungen basieren auf der bereitgestellten Abbildung

1.1.1. Zubehörtabelle

| Schrankteile | | | | |
|--------------|-----------------------------|---|----------------------------------|---------------|
| Pos.-Nr. | Bezeichnung | Abbildung | Benötigte Anzahl | Anzahl im Set |
| Teil A | Fronttür aus Glas |  | 1 Stk. | 1 Stk. |
| Teil B | Rückwand |  | 1 Stk. | 1 Stk. |
| Teil C | Seitenpaneele |  | 2 Stk. | 2 Stk. |
| Teil D | Rahmen |  | 2 Stk. | 2 Stk. |
| Teil E | Obere Abdeckung |  | 1 Stk. | 1 Stk. |
| Teil F | Untere Abdeckung |  | 1 Stk. | 1 Stk. |
| Teil G | Querstrebe |  | 15U~27U 4 Stk. 32U~42U 6 Stk. | |
| Teil H | Lüfterablage |  | 1 Stk. | 1 Stk. |
| Teil I | Montageschienen |  | 4 Stk. | 4 Stk. |
| Teil J | Abdeckung des oberen Panels |  | Flach 3 Stk. Gerillt 4 Stk. | |

| | | | | |
|--------|--------------------|--|-----------------------------------|--------|
| Teil K | Verstellbare FüÙe |  | 4 Stk. | 4 Stk. |
| Teil L | Rollen mit Bremsen |  | 4 Stk. | 4 Stk. |
| Teil M | TüranschlÙge |  | 15U~27U 8 Stk. 32U~42U 12 Stk. | |
| Teil N | Fronttürschloss |  | 1 Stk. | 1 Stk. |
| Teil O | Rückwandschloss |  | 3 Stk. | 3 Stk. |
| Teil W | Türabstandshalter |  | 2 Stk. | 4 Stk. |

| Schrauben | | | | |
|-----------|------------------------------------|---|------------------|---------------|
| Pos.-Nr. | Bezeichnung | Abbildung | Benötigte Anzahl | Anzahl im Set |
| Teil Q | M8 Inbusschraube |  | 16 Stk. | 17 Stk. |
| Teil R | Selbstschneidende Schrauben M5*10 |  | 15U~27U 36 Stk. | 40 Stk. |
| | | | 32U~42U 44 Stk. | 50 Stk. |
| Teil S | Selbstschneidende Schrauben M4*8 |  | 15U~27U 20 Stk. | 23 Stk. |
| | | | 32U~42U 26 Stk. | 30 Stk. |
| Teil T | M6-Käfigmutter |  | 15U~27U 32 Stk. | 35 Stk. |
| | | | 32U~42U 48 Stk. | 50 Stk. |
| Teil U | M6x12 Inbusschraube |  | 15U~27U 32 Stk. | 35 Stk. |
| | | | 32U~42U 48 Stk. | 52 Stk. |
| Teil V | Zusätzliche Schraube und Mutter M6 |  | 20 Stk. | 20 Stk. |

2. Montageschritte

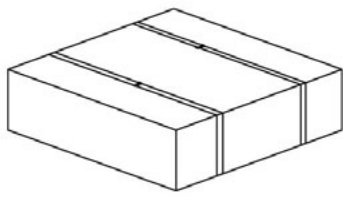

OBERES UND UNTERES
PAKET 1/3

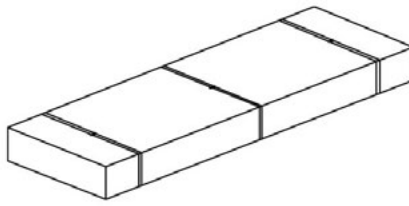

FRONTTÜR, RÜCKWAND UND
SEITENPANELE 2/3

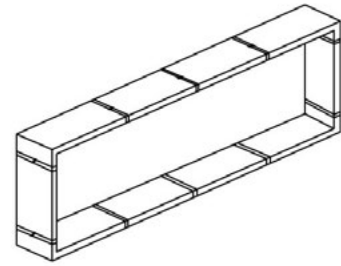

RAHMEN-PAKET 3/3

Schritt 1. Entfernen Sie das Fronttürschloss (Teil N), die Seitenpaneelschlösser und das Rückwandschloss (Teil O); die Komponenten befinden sich in Paket 1/3. Entfernen Sie dann die Fronttür aus Glas (Teil A), die Rückwand (Teil B) und die Seitenpaneelle (Teil C) aus Paket 2/3. In dieser Phase beginnen wir damit, die Schlösser an den oben genannten Komponenten anzubringen.



Schritt 2. Packen Sie die Rahmenteile (Teil J) aus Paket 3/3 aus. Richten Sie dann die Rahmen parallel zueinander aus, wobei die quadratischen Löcher nach innen zeigen. Den unteren Teil des Rahmens erkennen Sie an dem Element für die Erdung.

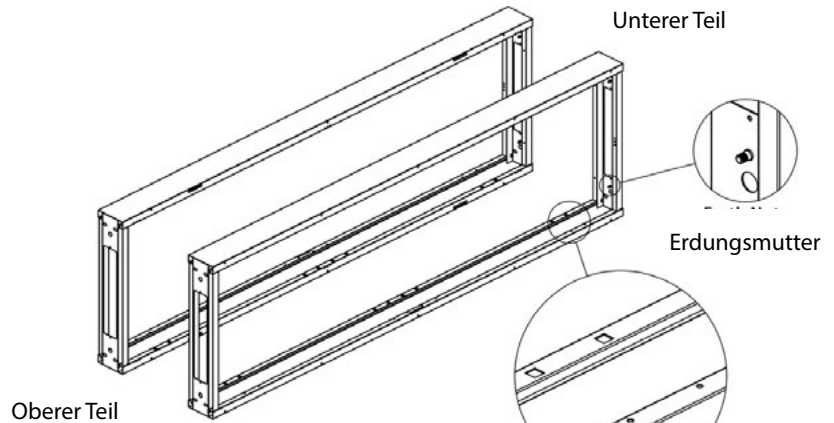

Schritt 3. Setzen Sie die obere Abdeckung (Teil E) auf den oberen Teil des Rahmens (Teil D) und verwenden Sie anschließend eine M8-Inbusschraube (Teil Q), um sie zu verbinden.

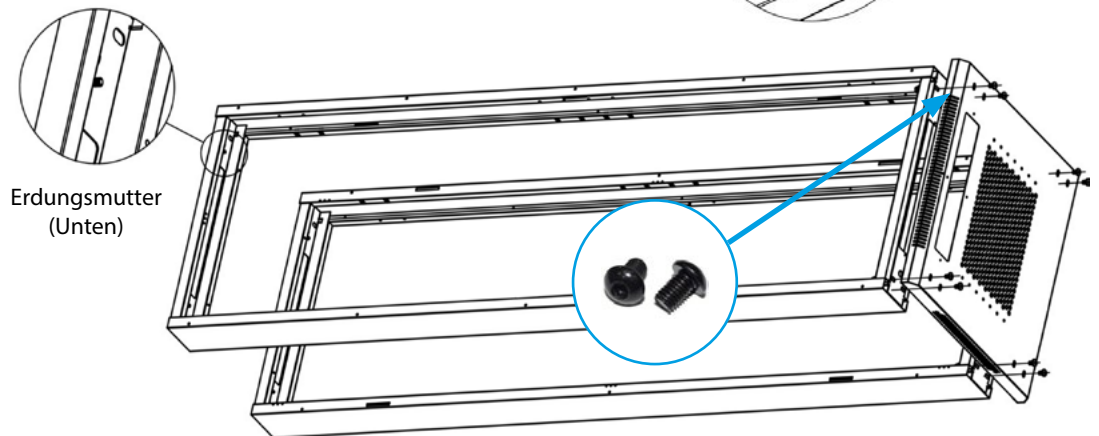

Schritt 4. Setzen Sie die untere Abdeckung (Teil F) auf den unteren Teil des Rahmens (Teil D) und verbinden Sie sie anschließend mit einem M8-Inbusbolzen (Teil Q).

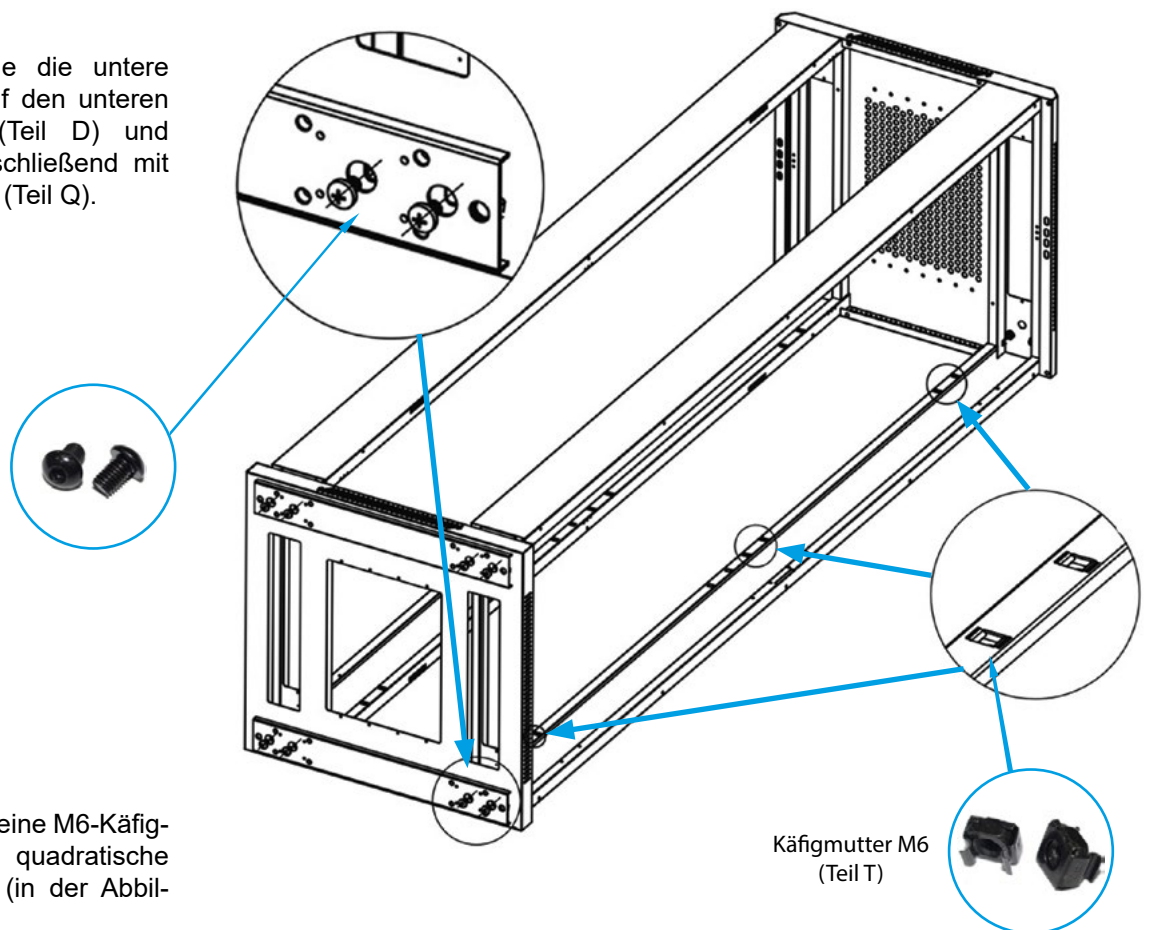

Schritt 4a. Setzen Sie eine M6-Käfigmutter (Teil T) in das quadratische Loch im Rahmen ein (in der Abbildung markiert).

Käfigmutter M6 (Teil T)

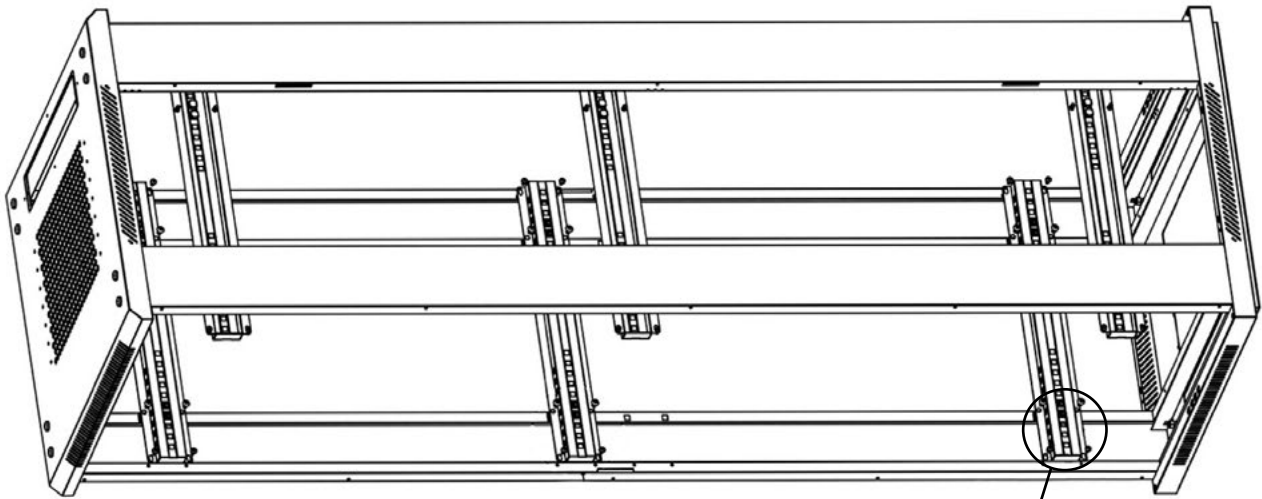

Inbusbolzen M6
(Teil U)

Schritt 5. Bereiten Sie M6-Käfigmuttern (Teil T) vor und befestigen Sie sie an der Querstrebe (Teil G). Setzen Sie anschließend die Querstrebe auf den Rahmen (Teil D), wobei Sie das Verriegelungsloch im Rahmen aussparen. Verwenden Sie eine M6-Inbusschraube (Teil U) und eine selbstschneidende M5-Schraube (Teil R), um die Querstrebe zu befestigen.

Selbstschneidende
Schraube M5 (Teil R)

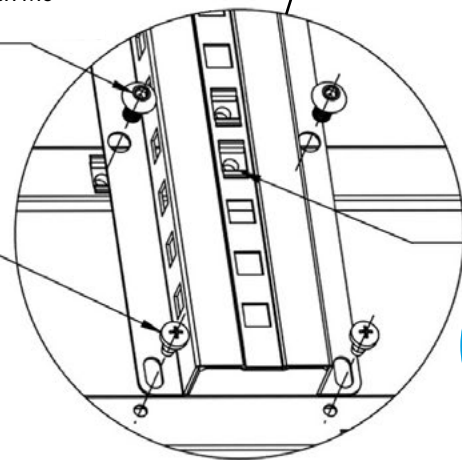

Käfigmutter
M6 (Teil T)

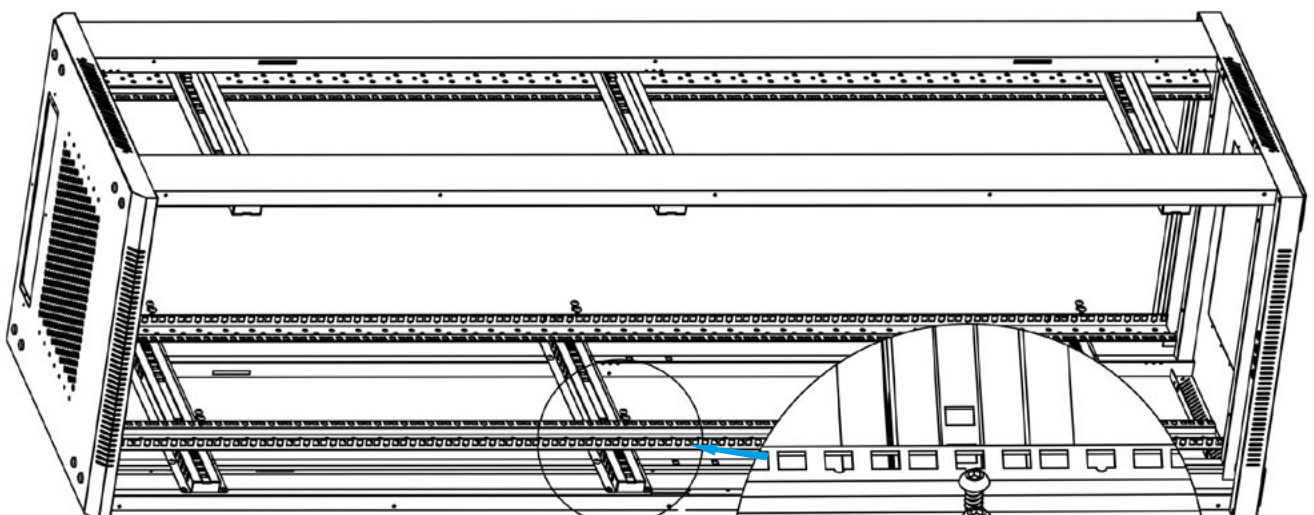

Schritt 6. Bereiten Sie M6-Montageschrauben (Teil U) vor. Verwenden Sie die Schrauben, um die vertikalen Montageschienen (Teil I) an den horizontalen Querstreben (Teil G) zu befestigen.



Inbusbolzen M6
(Teil U)

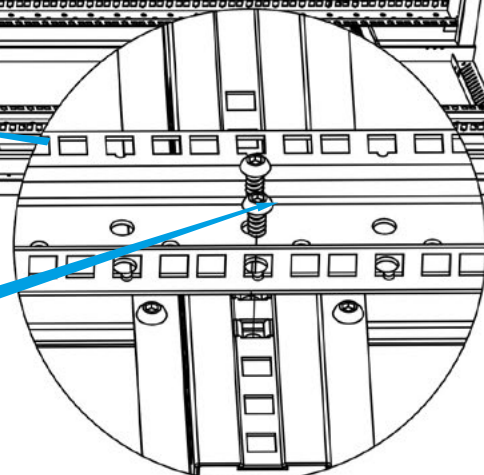

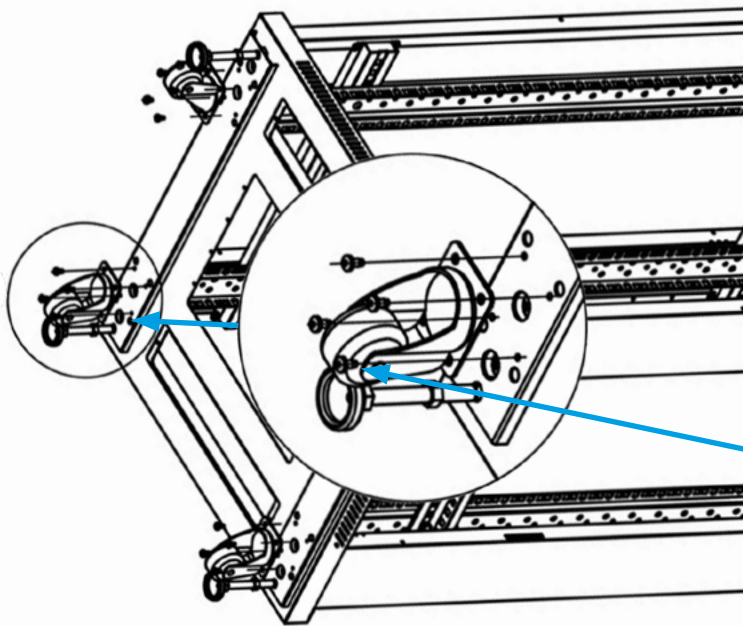

Schritt 7. Bereiten Sie selbstschneidende M5-Schrauben (Teil R) vor, um die vier Rollen mit Bremsen (Teil L) an der unteren Abdeckung (Teil F) zu befestigen. Montieren Sie anschließend die verstellbaren FüÙe (Teil K) an der unteren Abdeckung.



Selbstschneidende Schraube M5 (Teil R)

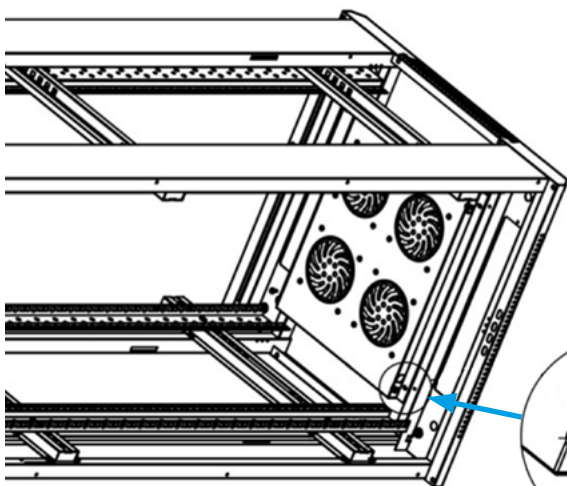

Schritt 8. Bereiten Sie selbstschneidende M5-Schrauben (Teil R) vor und verwenden Sie sie, um die Lüfterablage (Teil H) am RACK-Rahmen (Teil D) zu befestigen.



Selbstschneidende Schraube M5 (Teil R)

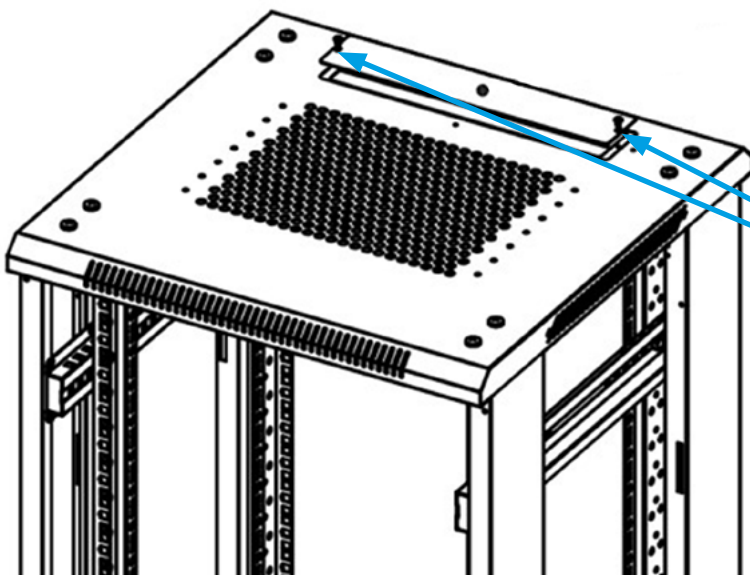

Schritt 9. Bereiten Sie eine selbstschneidende M4-Schraube (Teil S) vor und verwenden Sie sie, um die Abdeckung des oberen Panels (Teil J) zu befestigen.



Selbstschneidende Schraube M4 (Teil S)

Schritt 10. Bereiten Sie selbstschneidende M4-Schrauben (Teil S) vor und verwenden Sie sie, um die Türanschlüge (Teil M) zu befestigen. Für Größen 15U~27U (8 Stk.), 32U~47U (12 Stk.).



Selbstschneidende Schraube M4 (Teil S)

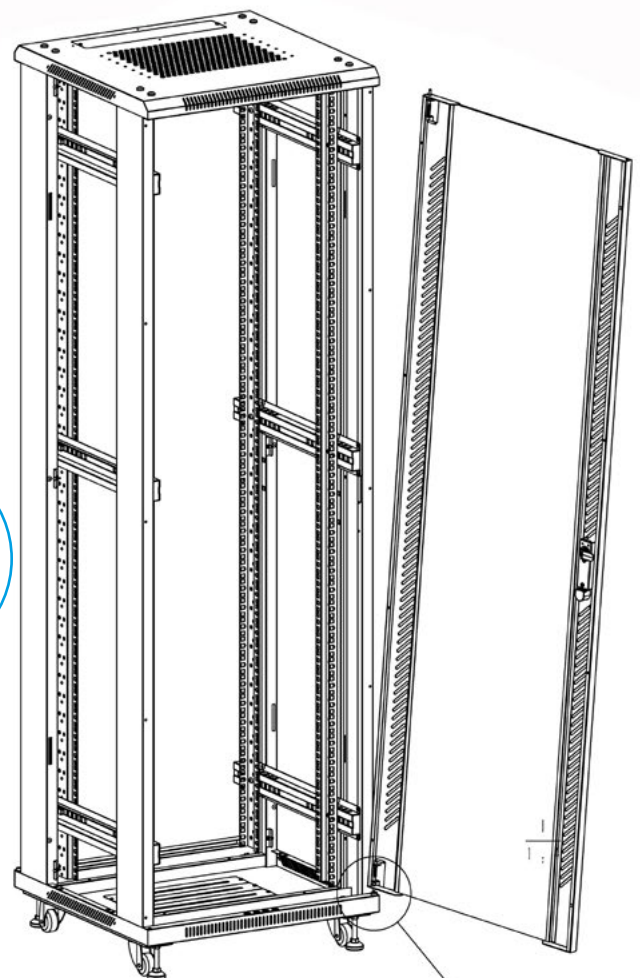
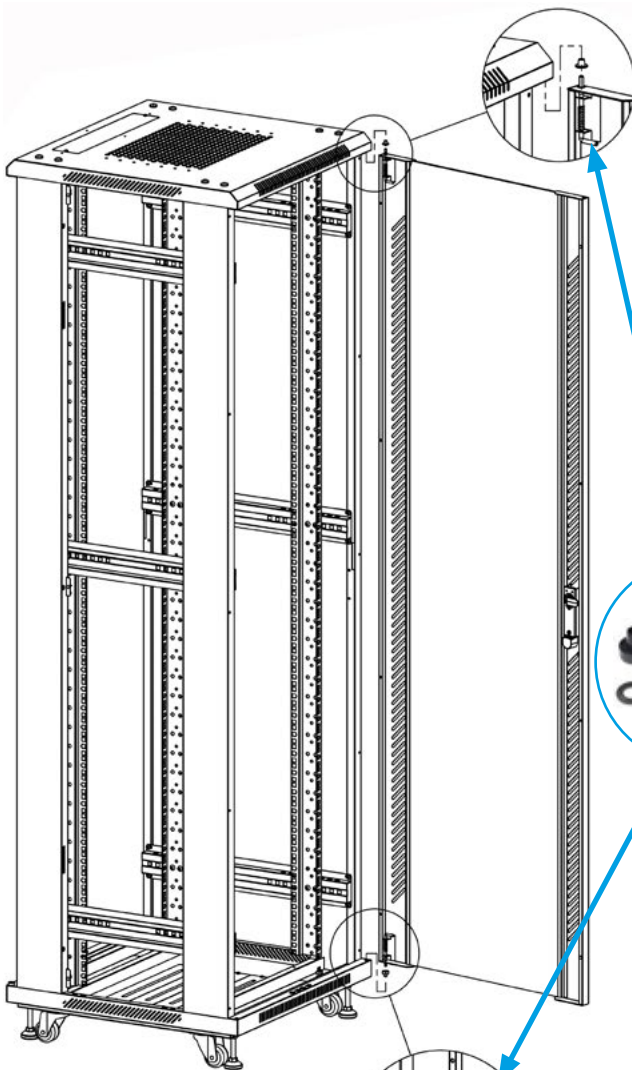
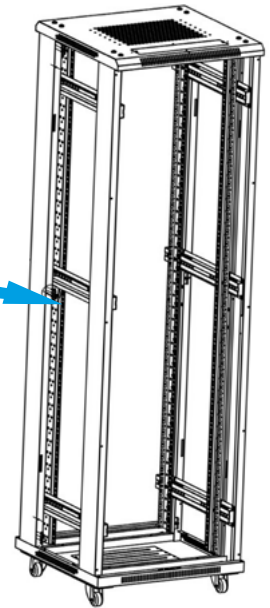
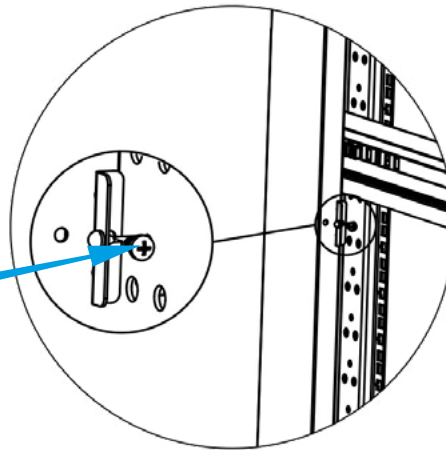

Schritt 11. Bereiten Sie die Türabstandshalter (Teil W) für die Fronttür und die Rückwand (Teile A und B) vor und setzen Sie sie an den entsprechenden Stellen ein. Montieren Sie die Seitenpaneele (Teil C) ganz zum Schluss.

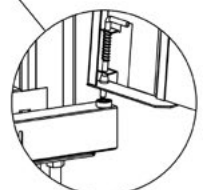









1. Monteringsanvisningar

i Se till att noggrant följa anvisningarna i denna manual.

1.1 Förberedelser

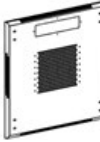
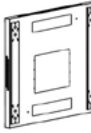
Förbered tillräckligt med fritt utrymme på ytan där monteringen ska ske. Ta försiktigt bort alla delar från transportlådan. De fortsatta monteringsanvisningarna baseras på det medföljande diagrammet

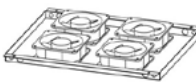
1.1.1. Tillbehörstabell

| Skåpdelar | | | | |
|------------|------------------|---|--------------------------------|---------------|
| Artikelnr. | Benämning | Illustration | Antal som behövs | Antal i setet |
| Del A | Glasfrontdörr |  | 1 st. | 1 st. |
| Del B | Bakpanel |  | 1 st. | 1 st. |
| Del C | Sidopaneler |  | 2 st. | 2 st. |
| Del D | Ram |  | 2 st. | 2 st. |
| Del E | Övre kåpa |  | 1 st. | 1 st. |
| Del F | Nedre kåpa |  | 1 st. | 1 st. |
| Del G | Tvärbalk |  | 15U~27U 4 st. 32U~42U 6 st. | |
| Del H | Fläkthylla |  | 1 st. | 1 st. |
| Del I | Monteringsskenor |  | 4 st. | 4 st. |
| Del J | Toppanelkåpa |  | Platt 3 st. Räfflad 4 st. | |

| | | | | |
|-------|-------------------|--|---------------------------------|-------|
| Del K | Justerbara fötter |  | 4 st. | 4 st. |
| Del L | Hjul med broms |  | 4 st. | 4 st. |
| Del M | Dörrstopp |  | 15U~27U 8 st. 32U~42U 12 st. | |
| Del N | Frontdörrlås |  | 1 st. | 1 st. |
| Del O | Bakpanellås |  | 3 st. | 3 st. |
| Del W | Dörrdistanser |  | 2 st. | 4 st. |

| Skrudar | | | | |
|------------|---------------------------|---|------------------|---------------|
| Artikelnr. | Benämning | Illustration | Antal som behövs | Antal i setet |
| Del Q | M8 insexskruv |  | 16 st. | 17 st. |
| Del R | M5*10 självgående skruvar |  | 15U~27U 36 st. | 40 st. |
| | | | 32U~42U 44 st. | 50 st. |
| Del S | M4*8 självgående skruvar |  | 15U~27U 20 st. | 23 st. |
| | | | 32U~42U 26 st. | 30 st. |
| Del T | M6 burmutter |  | 15U~27U 32 st. | 35 st. |
| | | | 32U~42U 48 st. | 50 st. |
| Del U | M6x12 insexskruv |  | 15U~27U 32 st. | 35 st. |
| | | | 32U~42U 48 st. | 52 st. |
| Del V | Extra skruv och mutter M6 |  | 20 st. | 20 st. |

2. Monteringssteg

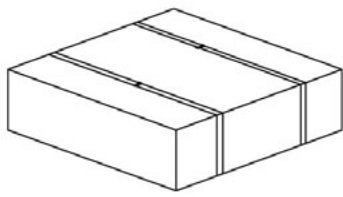

TOPP- OCH BOTTENPAKET 1/3

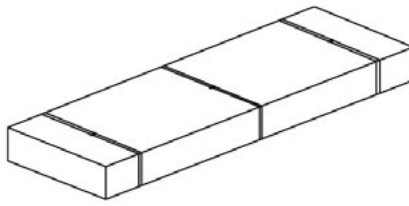

FRONTDÖRR, BAKPANEL OCH
SIDOPANELER 2/3

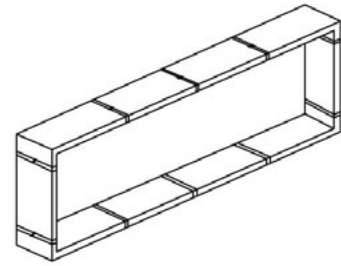

RAMPAKET 3/3

Steg 1. Ta bort frontdörrlåset (del N), sidopanellåsen och bakpanellåset (del O); komponenterna finns i paket 1/3. Ta sedan bort glasfrontdörren (del A), bakpanelen (del B) och sidopanelerna (del C) från paket 2/3. I detta skede börjar vi med att montera låsen på ovanstående komponenter.



Steg 2. Packa upp ramdelarna (del J) från paket 3/3. Placera sedan ramarna parallellt med varandra, med de fyrkantiga hålen vända inåt. Du kan känna igen den nedre delen av ramen genom elementet för jordning.

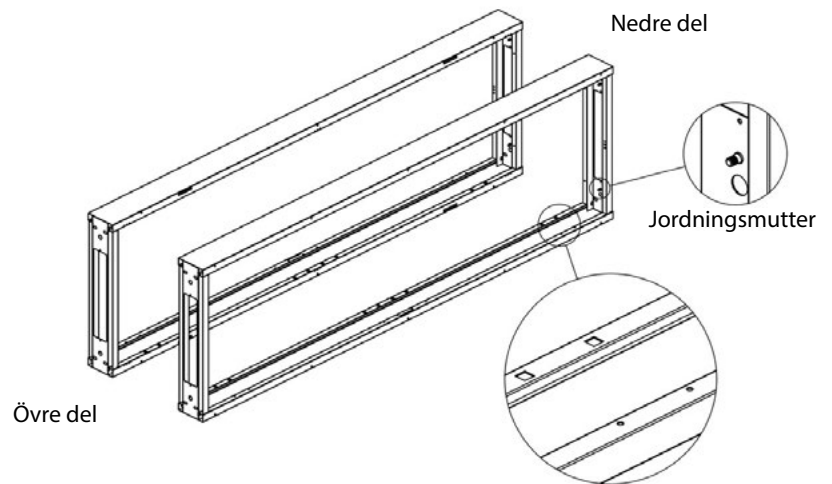

Steg 3. Montera den övre kåpan (del E) på den övre delen av ramen (del D) och använd sedan en M8 insexskruv (del Q) för att montera dem tillsammans.

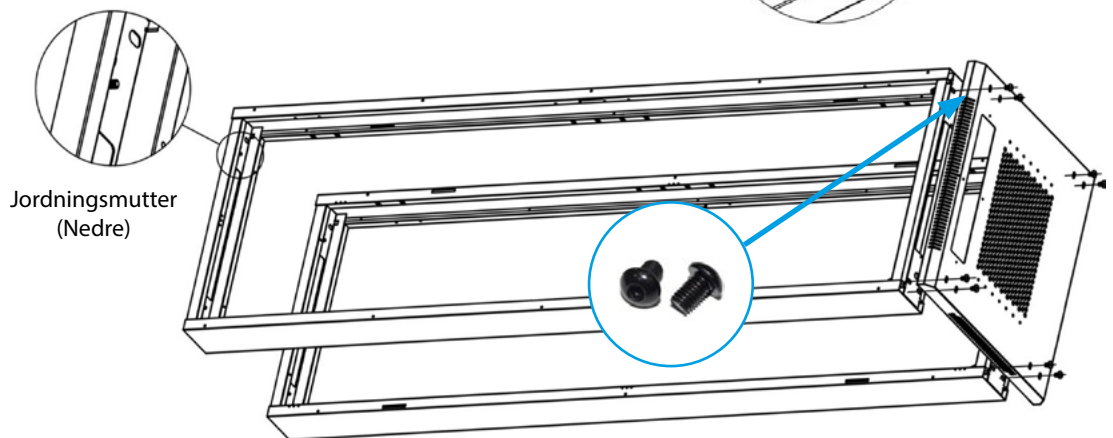

Steg 4. Montera den nedre kåpan (del F) på den nedre delen av ramen (del D) och använd sedan en M8 insexbult (del Q) för att sammanfoga dem.

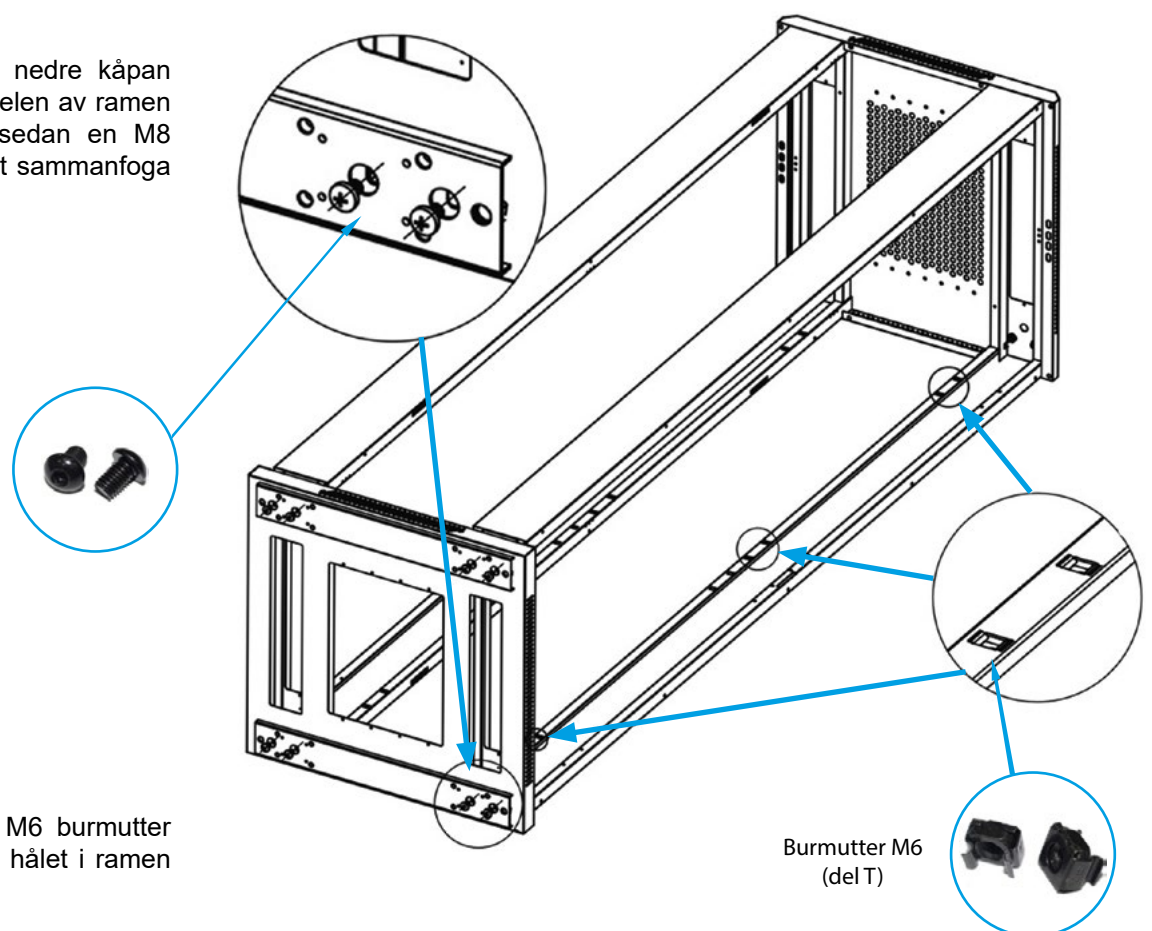

Steg 4a. Montera en M6 burmutter (del T) i det fyrkantiga hålet i ramen (markerat i figuren).

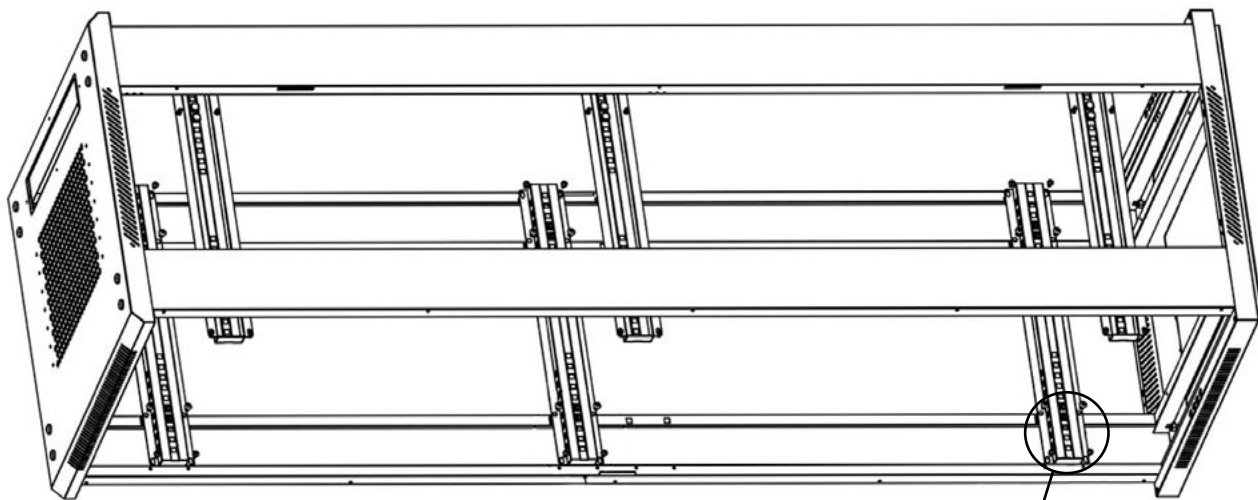

Steg 5. Förbered M6 burmuttrar (del T) och fäst dem på tvärbalken (del G); placera sedan tvärbalken på ramen (del D) och undvik låshålet i ramen. Använd en M6 insexskruv (del U) och en M5 självgående skruv (del R) för att fästa tvärbalken.

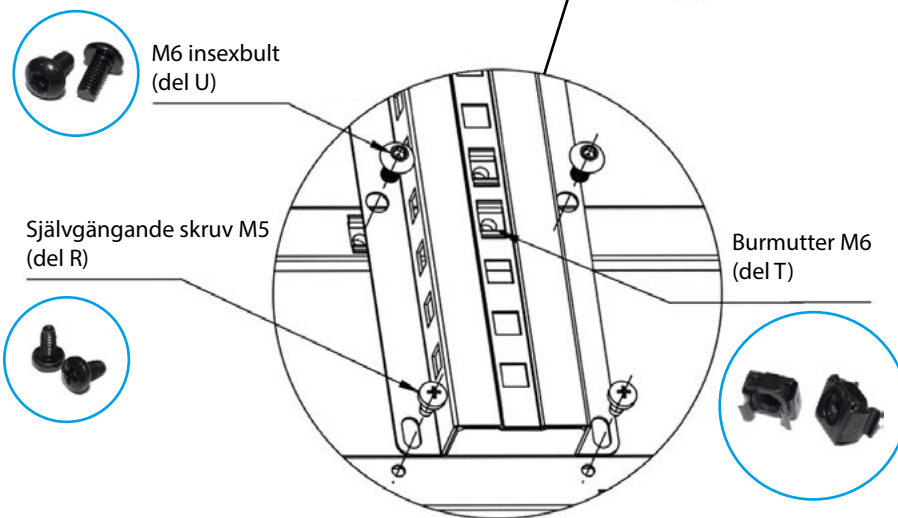

M6 insexbult (del U)



Självgående skruv M5 (del R)



Burmutter M6 (del T)

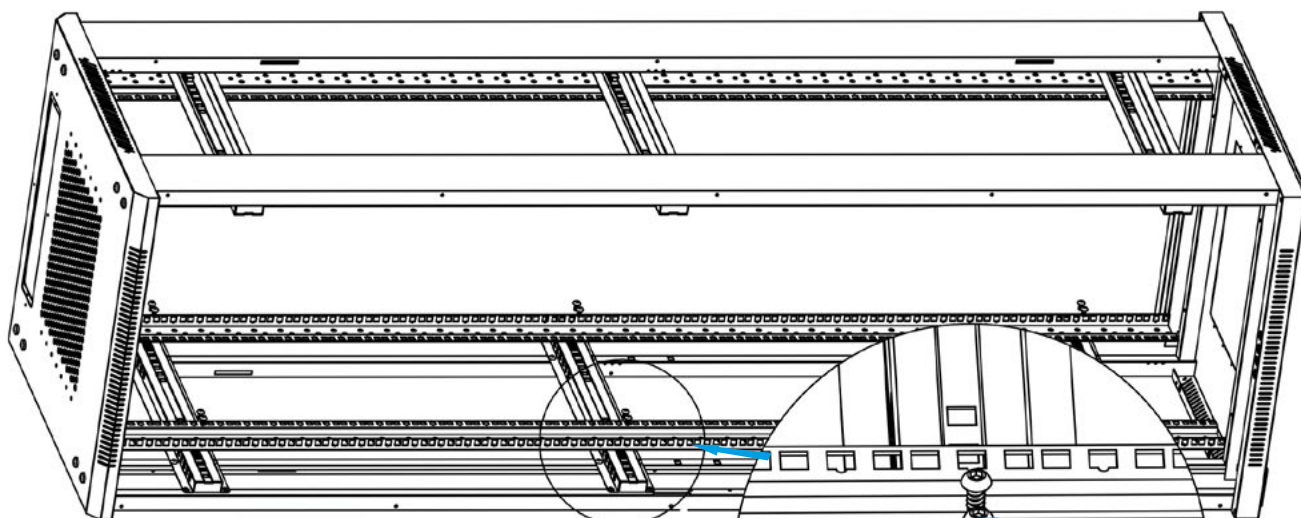

Steg 6. Förbered M6 monteringskruvar (del U). Använd skruvarna för att fästa de vertikala monteringskenorna (del I) på de horisontella tvärbalkarna (del G).



M6 insexbult (del U)

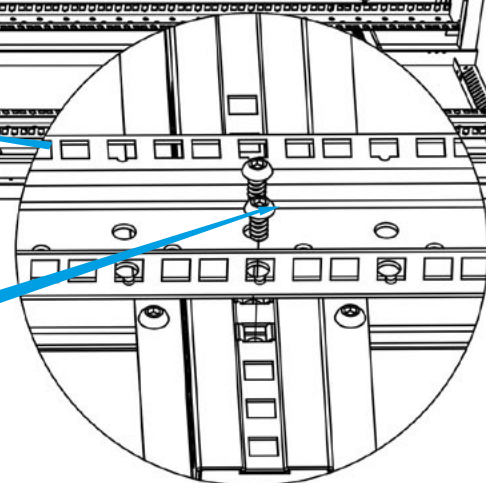

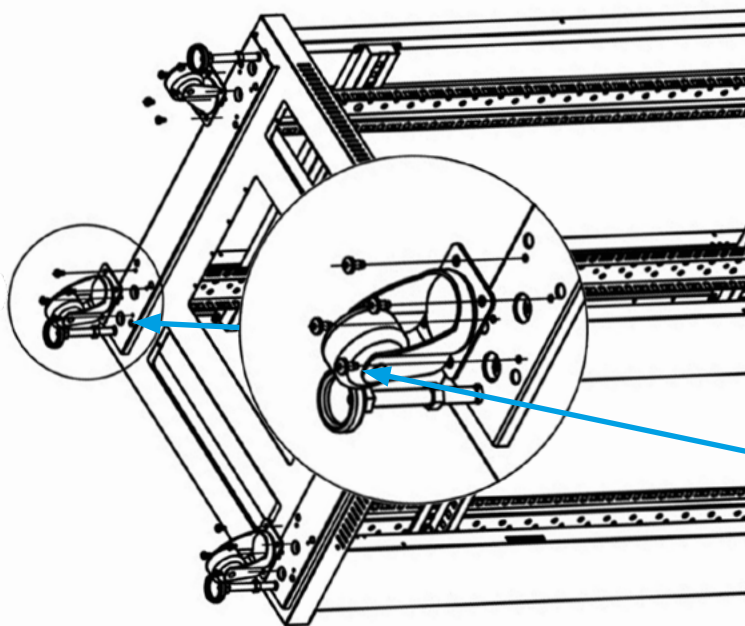

Steg 7. Förbered M5 självgående skruvar (del R) för att fästa de fyra hjulen med broms (del L) på den nedre kåpan (del F). Montera sedan de justerbara fötterna (del K) på den nedre kåpan.



Självgående skruv M5 (del R)

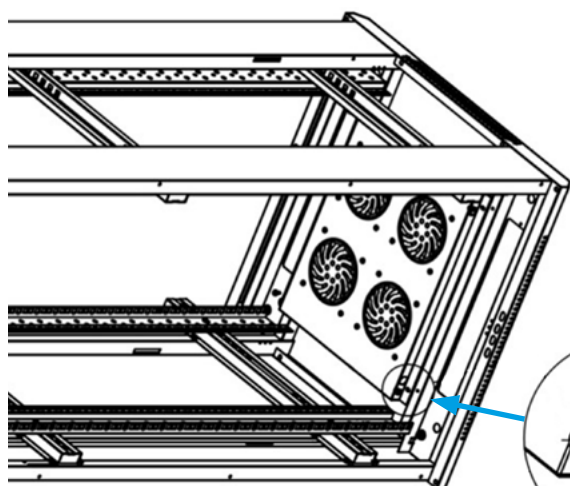

Steg 8. Förbered M5 självgående skruvar (del R) och använd dem för att fästa fläkthyllan (del H) på RACK-ramen (del D).



Självgående skruv M5 (del R)

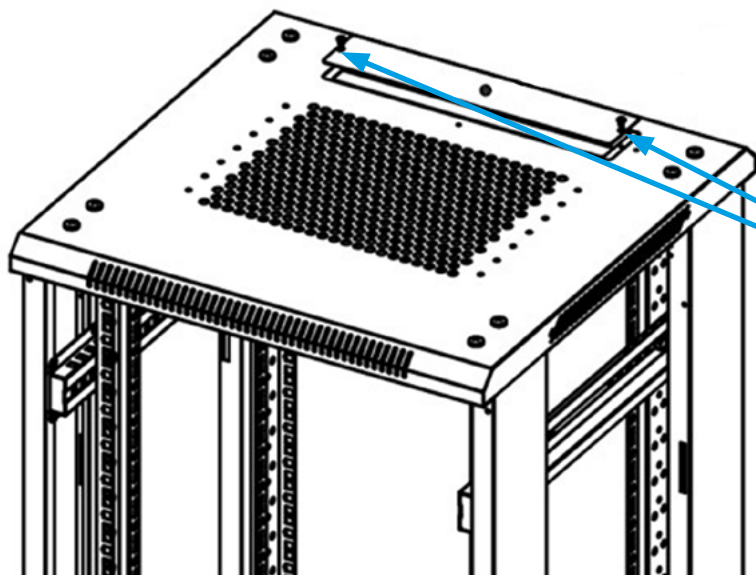

Steg 9. Förbered och använd en M4 självgående skruv (del S) för att fästa topppanelkåpan (del J).



Självgående skruv M4 (del S)

Steg 10. Förbered och använd M4 självgående skruvar (del S) för att fästa dörrstoppen (del M). För storlekar 15U~27U (8 st.), 32U~47U (12 st.).



Självgående skruv M4
(del S)

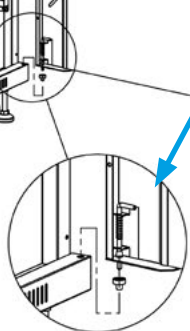
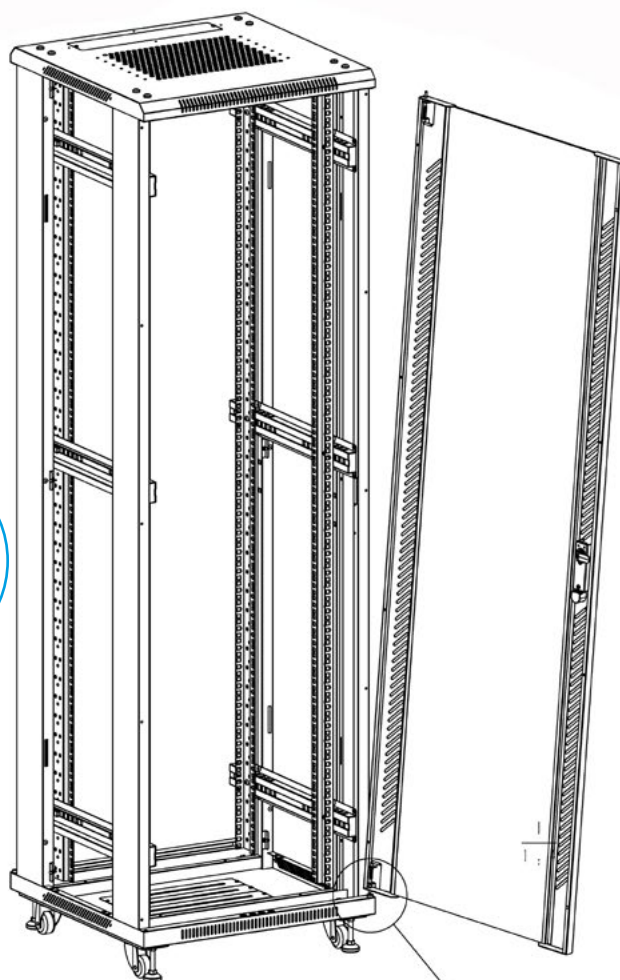
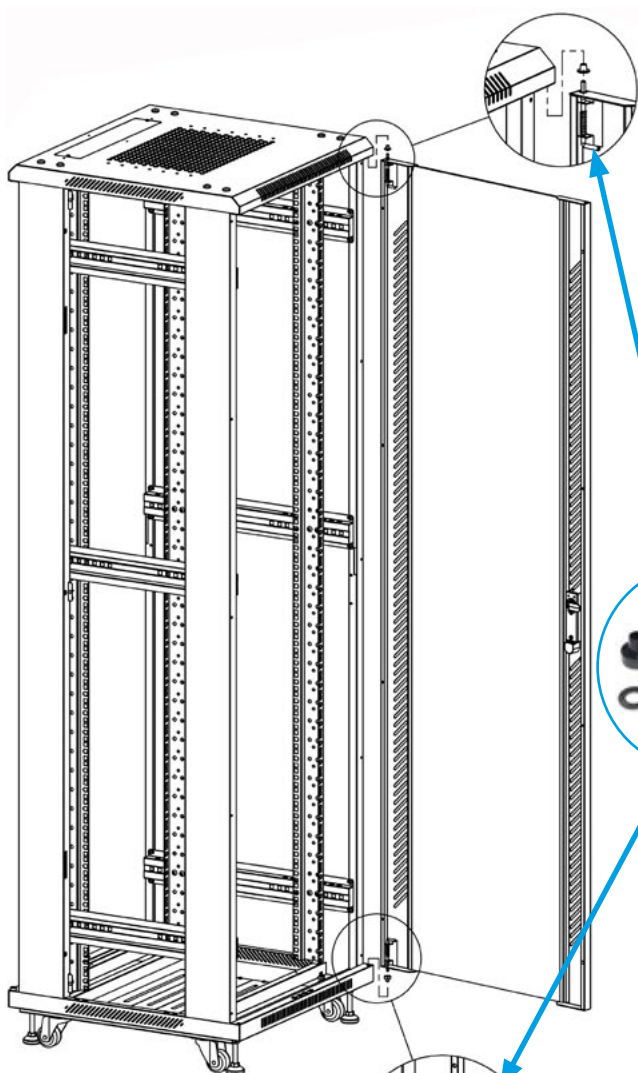
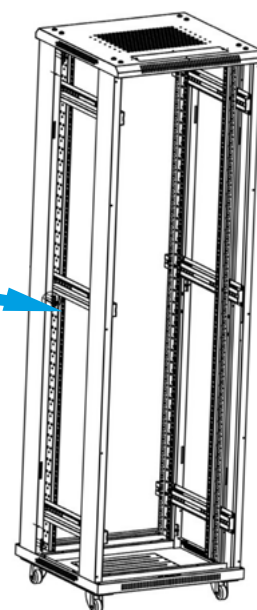
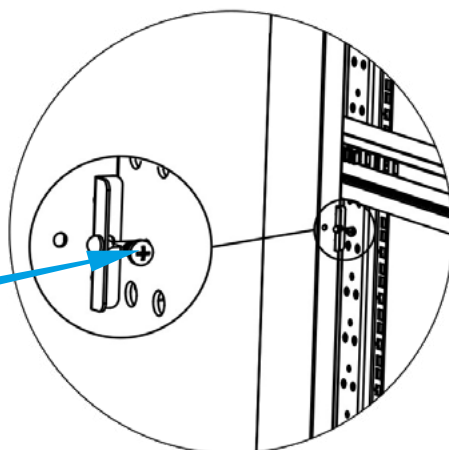

Steg 11. Förbered och placera dörrdistanserna (del W) för fröndörren och bakpanelen (delar A och B) på rätt ställen. Montera sidopanelerna (del C) allra sist.











1. Istruzioni di montaggio





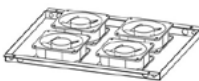

i Assicurarsi di seguire rigorosamente le istruzioni di questo manuale.

1.1 Preparazione

Preparare una quantità adeguata di spazio libero sulla superficie su cui avrà luogo il montaggio. Rimuovere con cura tutti gli elementi dalla scatola di trasporto. Le ulteriori istruzioni di montaggio si baseranno sul diagramma fornito

1.1.1. Tabella accessori

| Parti dell'armadio | | | | |
|--------------------|------------------------------|---|---------------------------------|------------------|
| N. articolo | Nome articolo | Disegno articolo | Quantità richiesta | Quantità nel set |
| Articolo A | Porta frontale in vetro |  | 1 pz. | 1 pz. |
| Articolo B | Pannello posteriore |  | 1 pz. | 1 pz. |
| Articolo C | Pannelli laterali |  | 2 pz. | 2 pz. |
| Articolo D | Telaio |  | 2 pz. | 2 pz. |
| Articolo E | Coperchio superiore |  | 1 pz. | 1 pz. |
| Articolo F | Coperchio inferiore |  | 1 pz. | 1 pz. |
| Articolo G | Traversa |  | 15U~27U 4 pz. 32U~42U 6 pz. | |
| Articolo H | Ripiano per ventole |  | 1 pz. | 1 pz. |
| Articolo I | Guide di montaggio |  | 4 pz. | 4 pz. |
| Articolo J | Tappo del pannello superiore |  | Piatto 3 pz. Scanalato 4 pz. | |

| | | | | |
|------------|-----------------------------------|--|---------------------------------|-------|
| Articolo K | Piedini regolabili |  | 4 pz. | 4 pz. |
| Articolo L | Ruote con freno |  | 4 pz. | 4 pz. |
| Articolo M | Fermiporta |  | 15U~27U 8 pz. 32U~42U 12 pz. | |
| Articolo N | Serratura della porta frontale |  | 1 pz. | 1 pz. |
| Articolo O | Serratura del pannello posteriore |  | 3 pz. | 3 pz. |
| Articolo W | Distanziatori porta |  | 2 pz. | 4 pz. |

| Viti | | | | |
|-------------|---------------------------|---|--------------------|------------------|
| N. articolo | Nome articolo | Disegno articolo | Quantità richiesta | Quantità nel set |
| Articolo Q | Vite a brugola M8 |  | 16 pz. | 17 pz. |
| Articolo R | Viti autofilettanti M5*10 |  | 15U~27U 36 pz. | 40 pz. |
| | | | 32U~42U 44 pz. | 50 pz. |
| Articolo S | Viti autofilettanti M4*8 |  | 15U~27U 20 pz. | 23 pz. |
| | | | 32U~42U 26 pz. | 30 pz. |
| Articolo T | Dado a gabbia M6 |  | 15U~27U 32 pz. | 35 pz. |
| | | | 32U~42U 48 pz. | 50 pz. |
| Articolo U | Vite a brugola M6x12 |  | 15U~27U 32 pz. | 35 pz. |
| | | | 32U~42U 48 pz. | 52 pz. |
| Articolo V | Vite e dado aggiuntivi M6 |  | 20 pz. | 20 pz. |

2. Fasi di montaggio

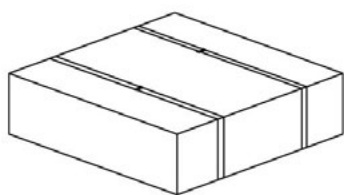

PACCHETTO SUPERIORE E INFERIORE 1/3

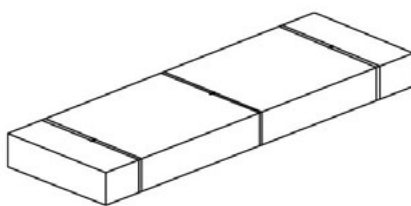

PORTA FRONTALE, PANNELLO POSTERIORE E PANNELLI LATERALI 2/3

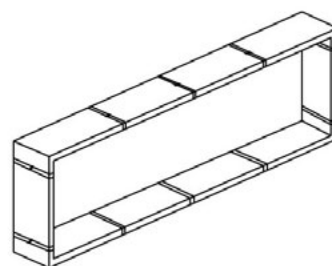

PACCHETTO TELAIO 3/3

Passo 1. Rimuovere la serratura della porta frontale (elemento N), le serrature dei pannelli laterali e la serratura del pannello posteriore (elemento O); i componenti sono nel pacco 1/3. Quindi rimuovere la porta frontale in vetro (elemento A), il pannello posteriore (elemento B) e i pannelli laterali (elemento C) dal pacco 2/3. In questa fase iniziamo installando le serrature sui componenti sopra indicati.

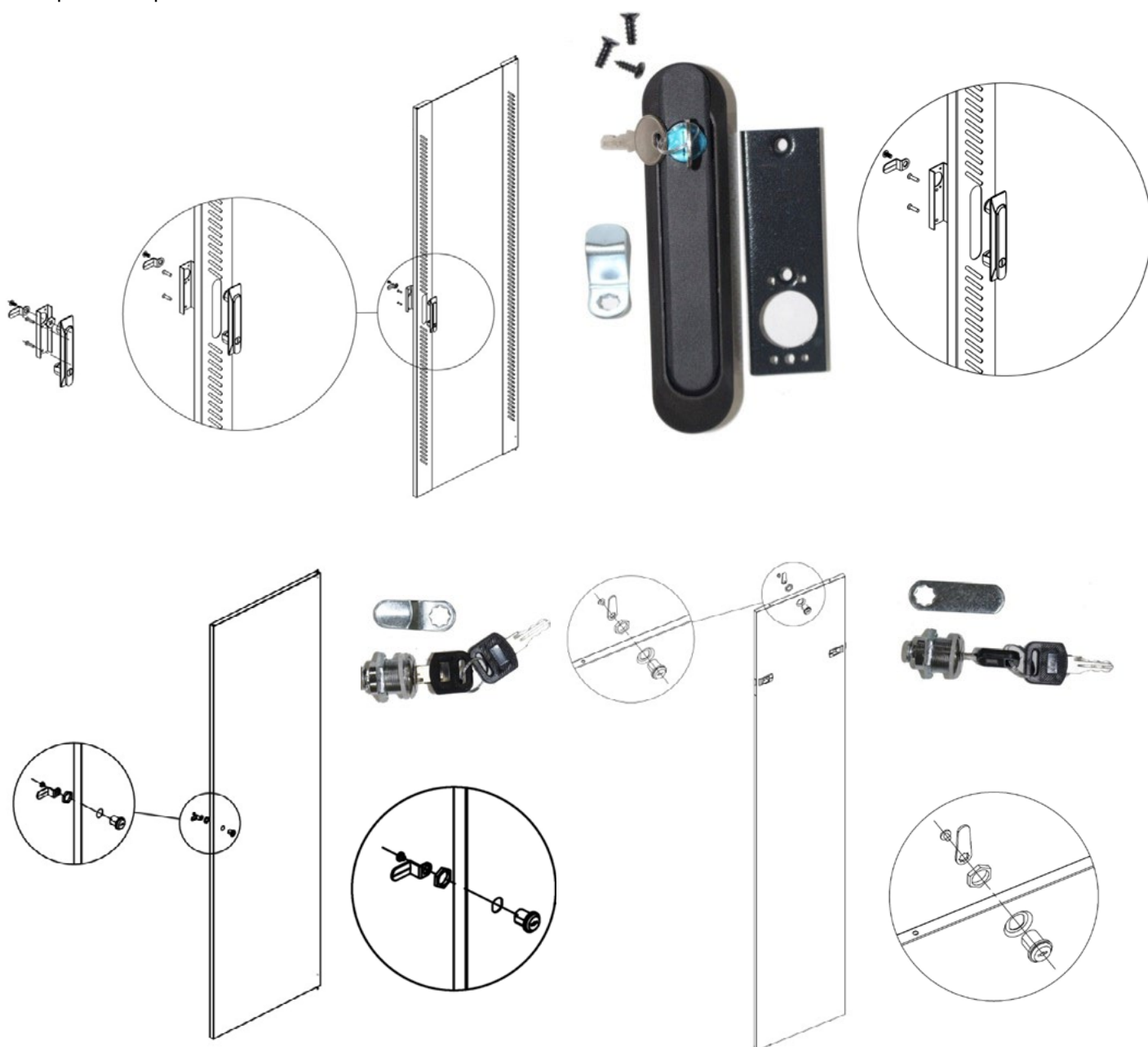

Passo 2. Disimballare le parti del telaio (elemento J) dal pacco 3/3. Quindi disporre i telai parallelamente tra loro, con i fori quadrati rivolti verso l'interno. È possibile riconoscere la parte inferiore del telaio dall'elemento per l'installazione della messa a terra.

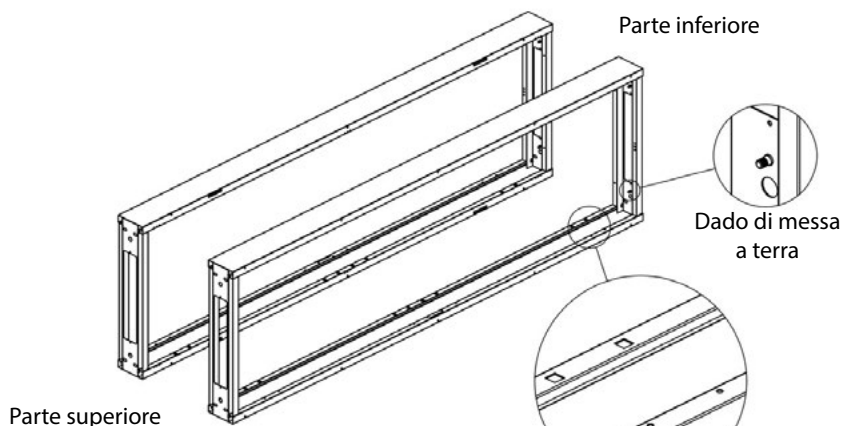

Passo 3. Montare il coperchio superiore (elemento E) sulla parte superiore del telaio (elemento D), quindi utilizzare una vite a brugola M8 (elemento Q) per assemblarli insieme.

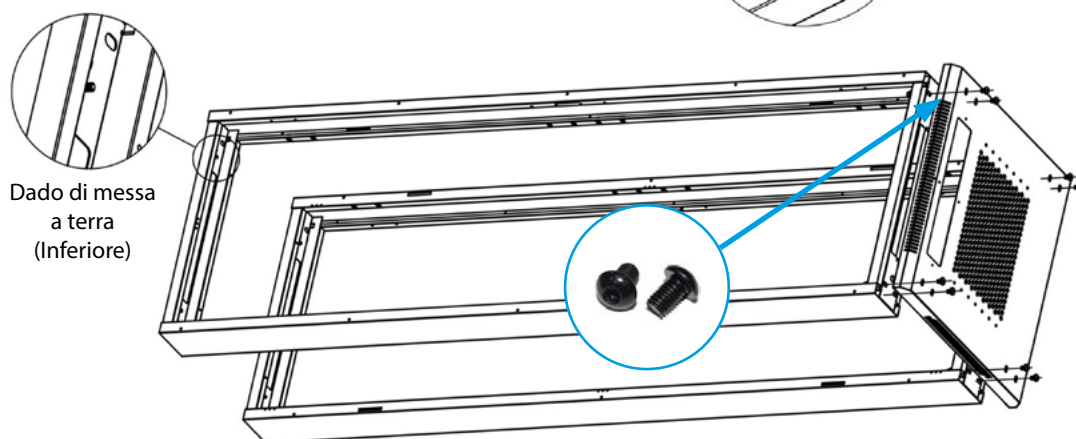

Passo 4. Montare il coperchio inferiore (elemento F) sulla parte inferiore del telaio (elemento D) e quindi utilizzare un bullone a brugola M8 (elemento Q) per unirli.

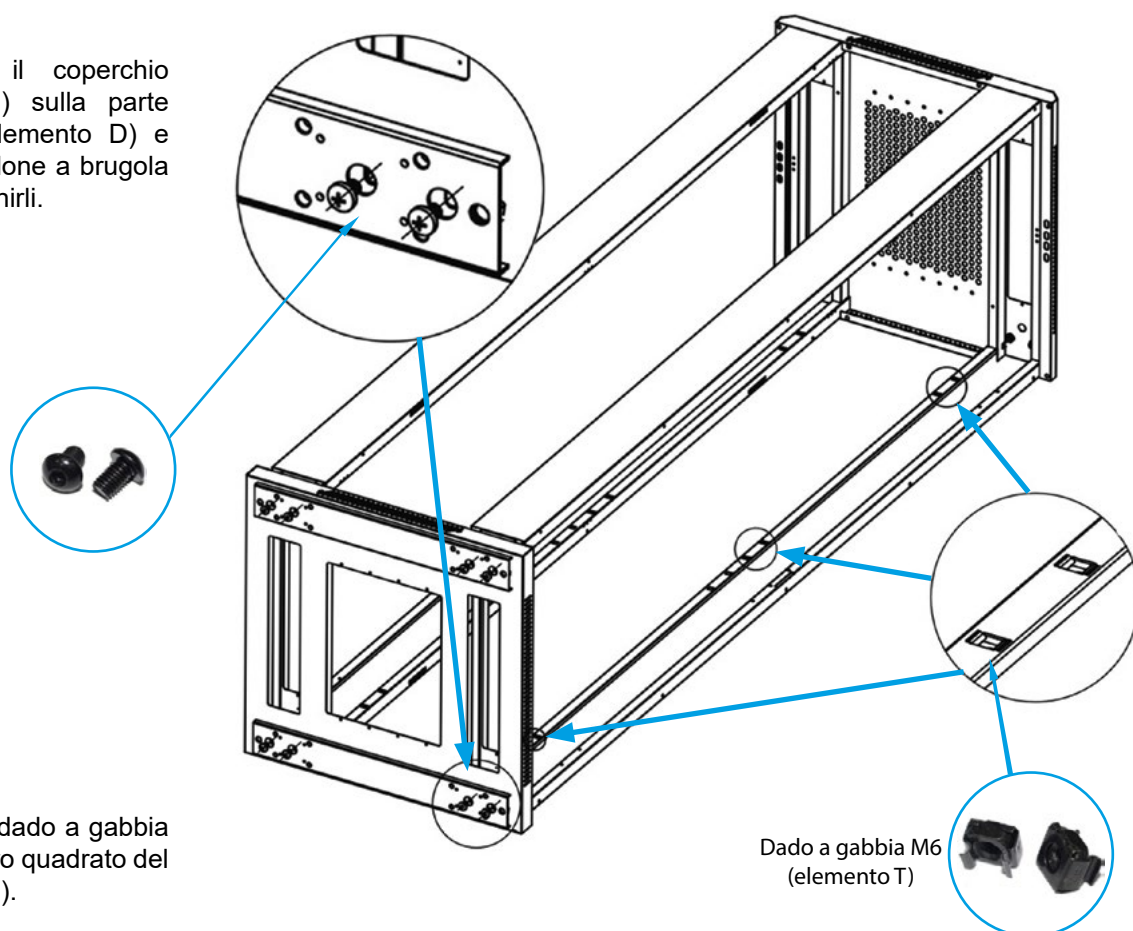

Passo 4a. Inserire un dado a gabbia M6 (elemento T) nel foro quadrato del telaio (indicato in figura).

Dado a gabbia M6 (elemento T)



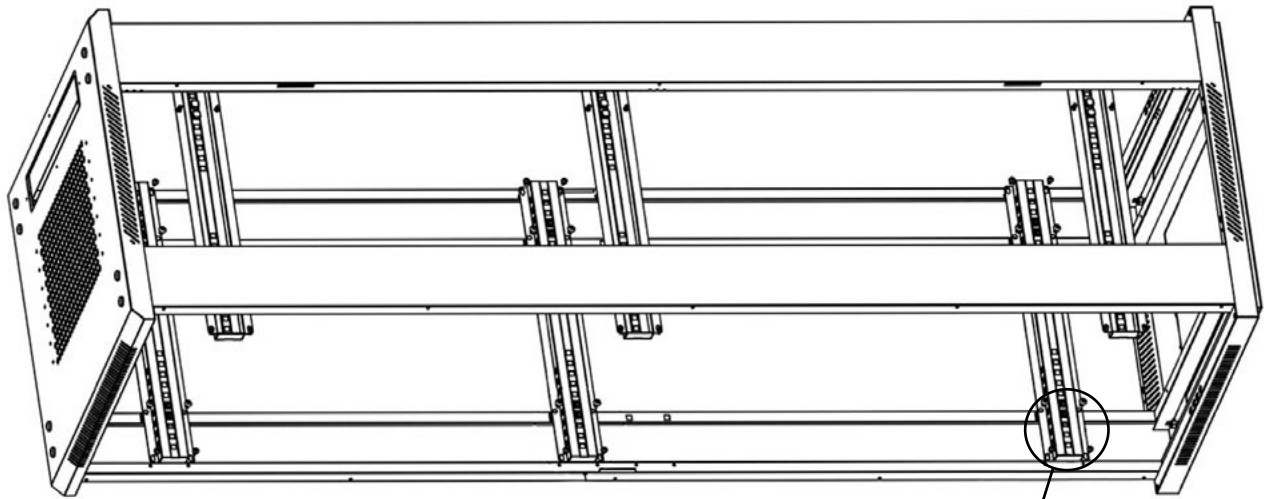

Bullone a brugola M6
(elemento U)

Passo 5. Preparare i dadi a gabbia M6 (elemento T) e fissarli alla traversa (elemento G), quindi posizionare la traversa sul telaio (elemento D) evitando il foro di bloccaggio nel telaio. Utilizzare una vite a brugola M6 (elemento U) e una vite autofilettante M5 (elemento R) per fissare la traversa.

Vite autofilettante M5
(elemento R)

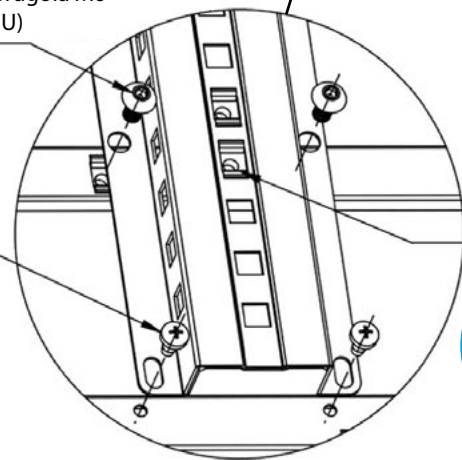

Dado a gabbia
M6 (elemento T)

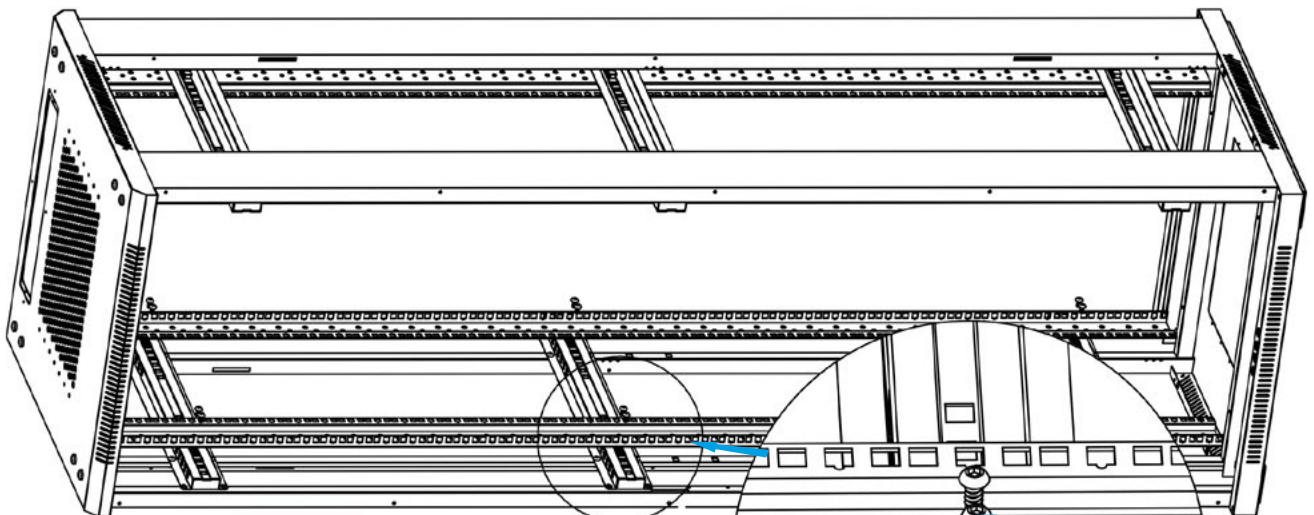

Passo 6. Preparare le viti di montaggio M6 (elemento U). Utilizzare le viti per fissare le guide di montaggio verticali (elemento I) alle traverse orizzontali (elemento G).



Bullone a brugola M6
(elemento U)

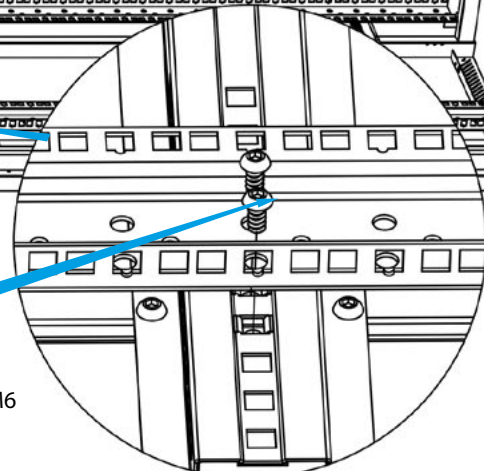

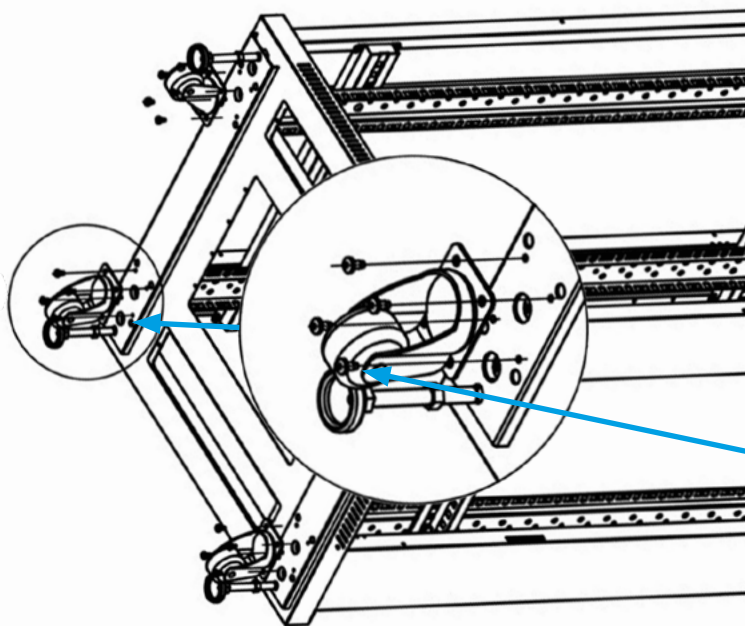

Passo 7. Preparare le viti autofilettanti M5 (elemento R) per fissare le quattro ruote con freno (elemento L) al coperchio inferiore (elemento F). Quindi montare i piedini regolabili (elemento K) al coperchio inferiore.



Vite autofilettante M5 (elemento R)

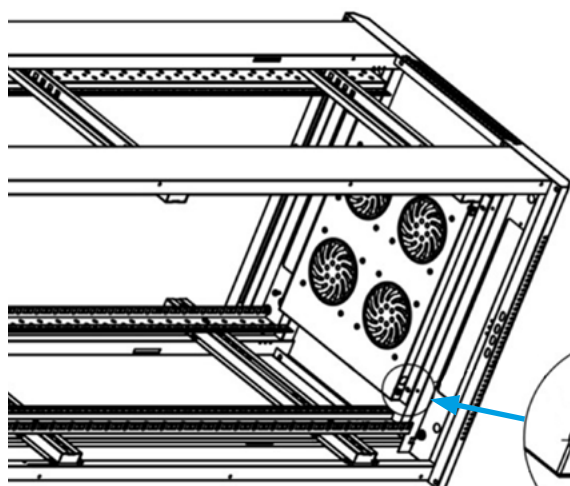

Passo 8. Preparare le viti autofilettanti M5 (elemento R), quindi usarle per fissare il ripiano per ventole (elemento H) al telaio RACK (elemento D).



Vite autofilettante M5 (elemento R)

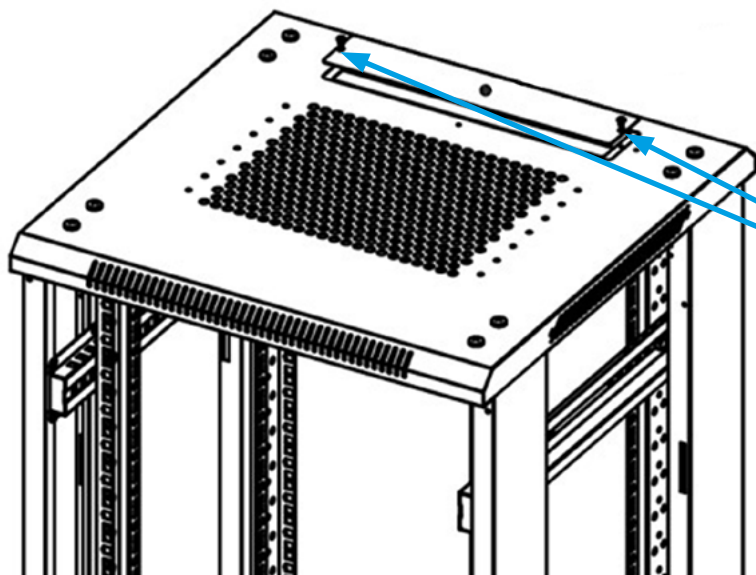

Passo 9. Preparare e utilizzare una vite autofilettante M4 (elemento S) per fissare il tappo del pannello superiore (elemento J).



Vite autofilettante M4 (elemento S)

Passo 10. Preparare e utilizzare le viti autofilettanti M4 (elemento S) per fissare i fermiporta (elemento M). Per le misure 15U~27U (8 pz.), 32U~47U (12 pz.).



Vite autofilettante M4
(elemento S)

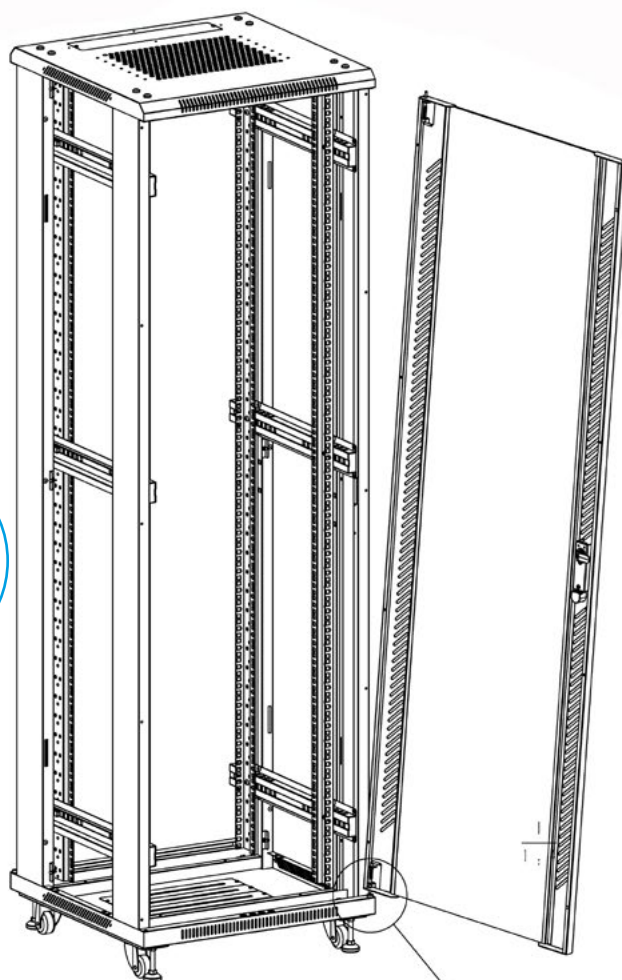
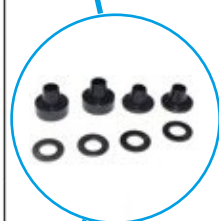
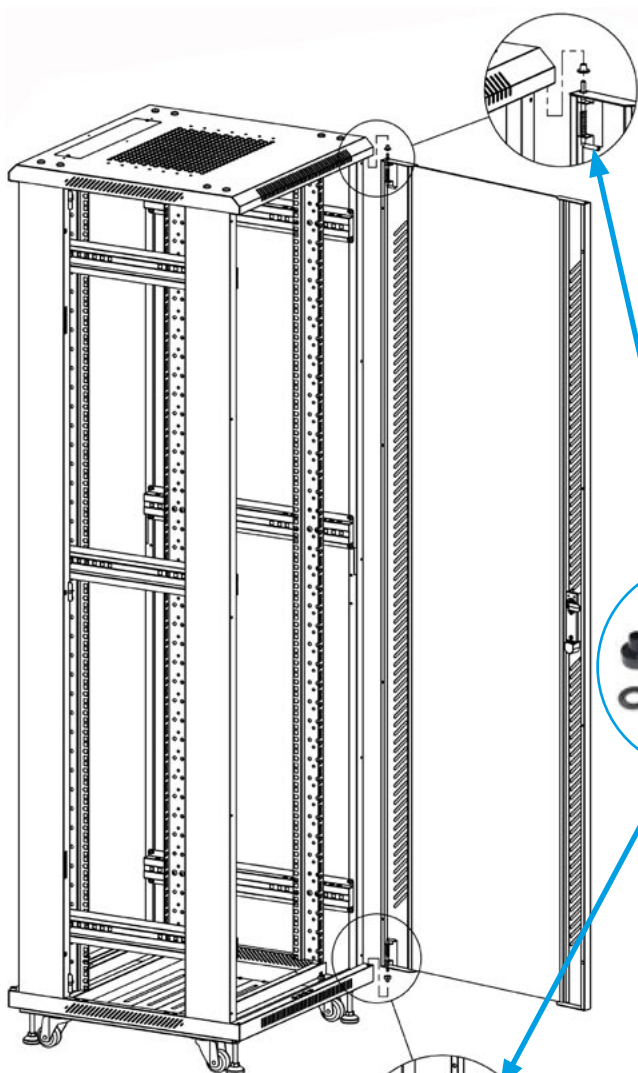
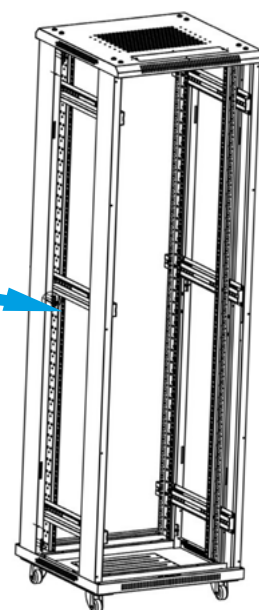
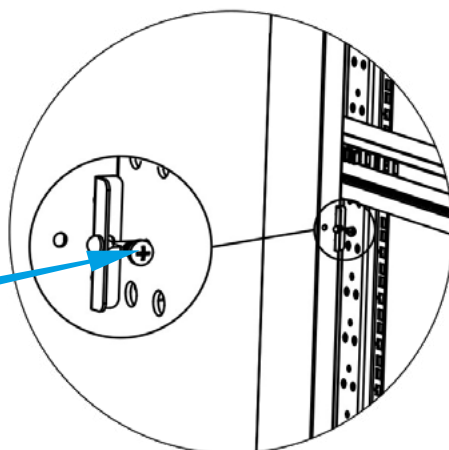

Passo 11. Preparare e posizionare i distanziatori porta (elemento W) per la porta frontale e il pannello posteriore (elementi A e B) nei punti appropriati. Montare i pannelli laterali (elemento C) solo alla fine.











1. Montaż





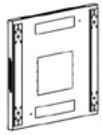

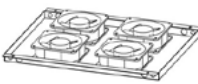
i **Należy ściśle przestrzegać zaleceń zawartych w tej instrukcji.**

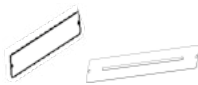
1.1 Przygotowanie

Przygotuj odpowiednią ilość miejsca na podłożu na którym odbędzie się montaż. Ostrożnie wyjmij wszystkie elementy z kartonu transportowego. Dalsze instrukcje montażu będą opierać się o zawarty schemat.

1.1.1. Zestawienie elementów

| Części szafy | | | | |
|--------------|------------------------|---|---------------------------------------|-------------------|
| Nr. elementu | Nazwa | Rysunek elementu | Wymagana liczba | Liczba w zestawie |
| Element A | Drzwi przednie szklane |  | 1 szt. | 1 szt. |
| Element B | Panel tylny |  | 1 szt. | 1 szt. |
| Element C | Panel boczny |  | 2 szt. | 2 szt. |
| Element D | Rama |  | 2 szt. | 2 szt. |
| Element E | Pokrywa górna |  | 1 szt. | 1 szt. |
| Element F | Dolna pokrywa |  | 1 szt. | 1 szt. |
| Element G | Listwa poprzeczna |  | 15U~27U 4 szt. 32U~42U 6 szt. | |
| Element H | Pokrywa wentylatora |  | 1 szt. | 1 szt. |
| Element I | Szyna montażowa |  | 4 szt. | 4 szt. |
| Element J | Zaślepka panelu |  | Płaska 3 szt. Z wyłobieniem 4 szt. | |

| | | | | |
|-----------|---------------------------------|--|-----------------------------------|--------|
| Element K | Nóżki szafy |  | 4 szt. | 4 szt. |
| Element L | Kółka z hamulcami |  | 4 szt. | 4 szt. |
| Element M | Ogranicznik do drzwi |  | 15U~27U 8 szt. 32U~42U 12 szt. | |
| Element N | Zamek drzwi przednich |  | 1 szt. | 1 szt. |
| Element O | Zamek panelu tylnego / bocznego |  | 3 szt. | 3 szt. |
| Element W | Dystanse drzwi przednich |  | 2 szt. | 4 szt. |

| Śruby | | | | |
|--------------|-------------------------------|---|-----------------|-------------------|
| Nr. elementu | Nazwa elementu | Rysunek elementu | Wymagana liczba | Liczba w zestawie |
| Element Q | M8 Śruba imbusowa |  | 16 szt. | 17 szt. |
| Element R | M5*10 Śruba samogwintująca |  | 15U~27U 36 szt. | 40 szt. |
| | | | 32U~42U 44 szt. | 50 szt. |
| Element S | M4*8 Śruba samogwintująca |  | 15U~27U 20 szt. | 23 szt. |
| | | | 32U~42U 26 szt. | 30 szt. |
| Element T | M6 Nakrętka zatrzaskowa |  | 15U~27U 32 szt. | 35 szt. |
| | | | 32U~42U 48 szt. | 50 szt. |
| Element U | M6x12 Śruba imbusowa |  | 15U~27U 32 szt. | 35 szt. |
| | | | 32U~42U 48 szt. | 52 szt. |
| Element V | M6 Dodatkowo śruba i nakrętka |  | 20 szt. | 20 szt. |

2. Etapy montażu

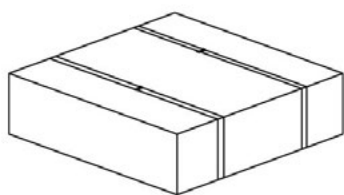

PAKIET GÓRA I DÓŁ 1/3

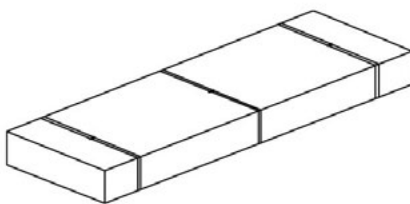

PAKIET DRZWI PRZEDNIE,
TYLNE I BOCZNE 2/3

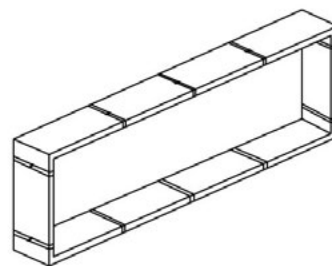

PAKIET RAMY 3/3

Krok 1. Wyjmij zamek drzwi przednich (element N), zamek paneli bocznych oraz panelu tylnego (element O), elementy znajdują się w opakowaniu 1/3. Następnie wyjmij przednie szklane drzwi (element A), tylne drzwi stalowe (element B) oraz panele boczne (element C) z opakowania 2/3. Na tym etapie zaczynamy montaż zamków do podanych elementów.



Krok 2. Rozpakuj elementy ramy (część J) z opakowania 3/3. Następnie ułóż ramy równoległe do siebie, kwadratowymi otworami do wewnątrz. Dolną część ramy rozpoznamy po elemencie do zamontowania uziemienia.

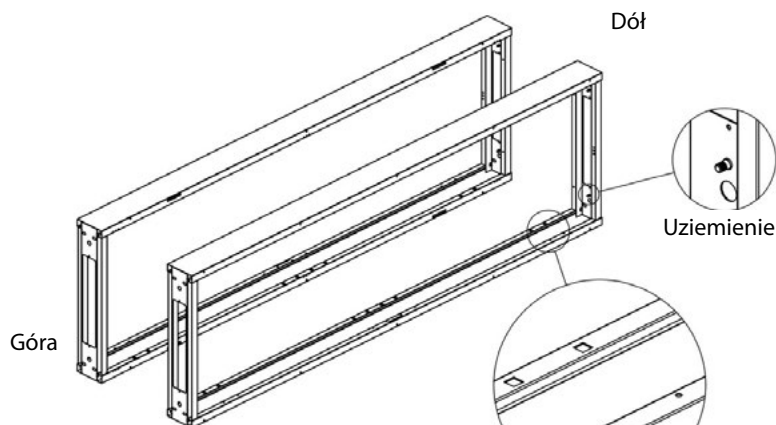

Krok 3. Załóż górną pokrywę (element E) na górną część ramy (część D), a następnie użyj śruby imbusowej M8 (część Q) aby zmontować je razem.

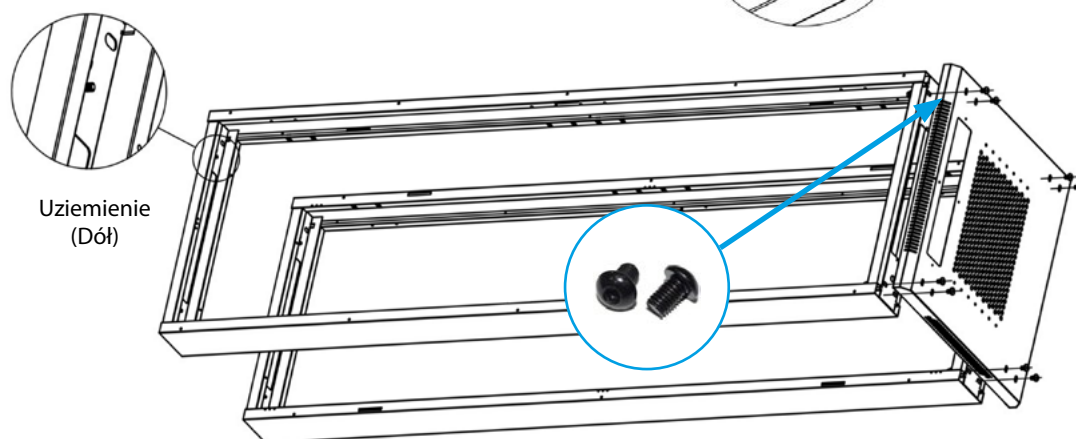

Krok 4. Załóż dolną pokrywę (element F) na dolny element ramy (element D) a następnie użyj śruby imbusowej M8 (element Q) aby je połączyć.

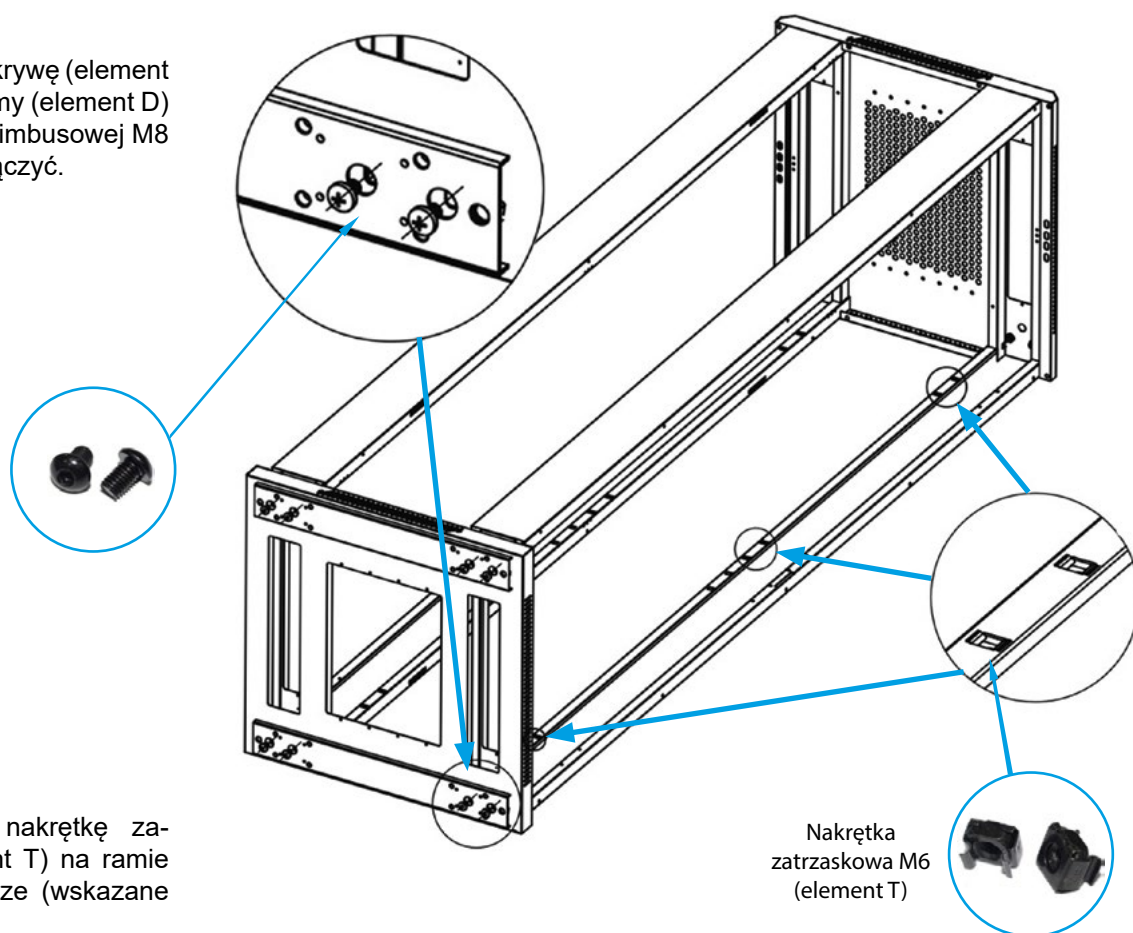

Krok 4a. Zamontuj nakrętkę zatrzaskową M6 (element T) na ramie w kwadratowym otworze (wskazane na rysunku).

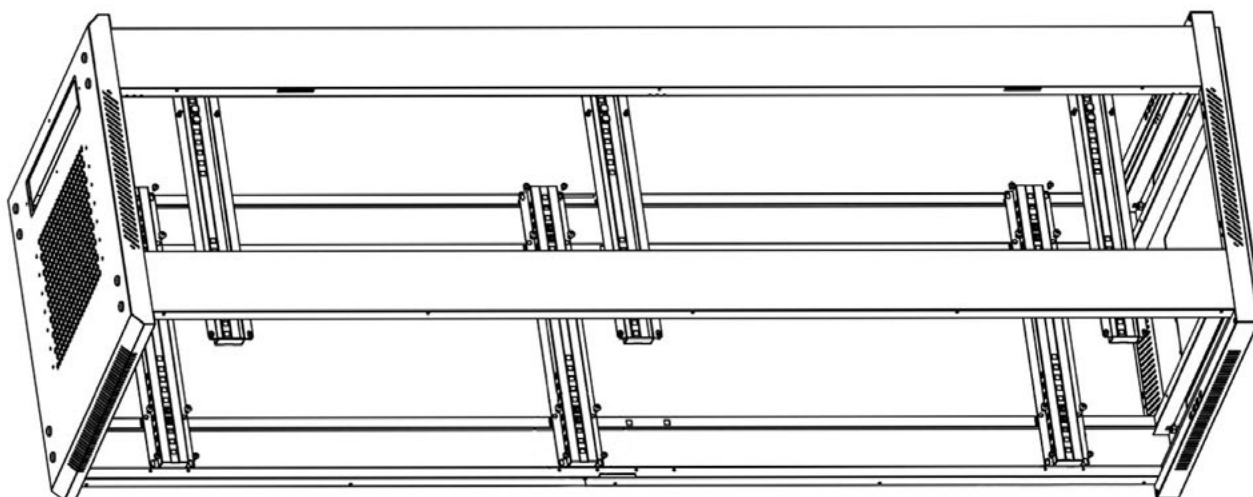

Śruba imbusowa M6
(element U)

Krok 5. Przygotuj nakrętki zatraskowe M6 (element T) i zamocuj je na listwie poprzecznej (element G), następnie umieść listwę poprzeczną na ramie (element D) unikając otworu blokującego w ramie. Do zamocowania listwy użyj śruby imbusowej M6 (element U) i wkrętu samogwintującego M5 (element R).

Śruba samogwintująca
M5 (element R)

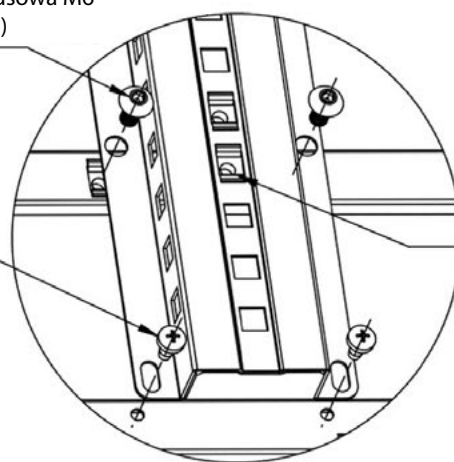

Nakrętki
zatraskowe M6
(element T)

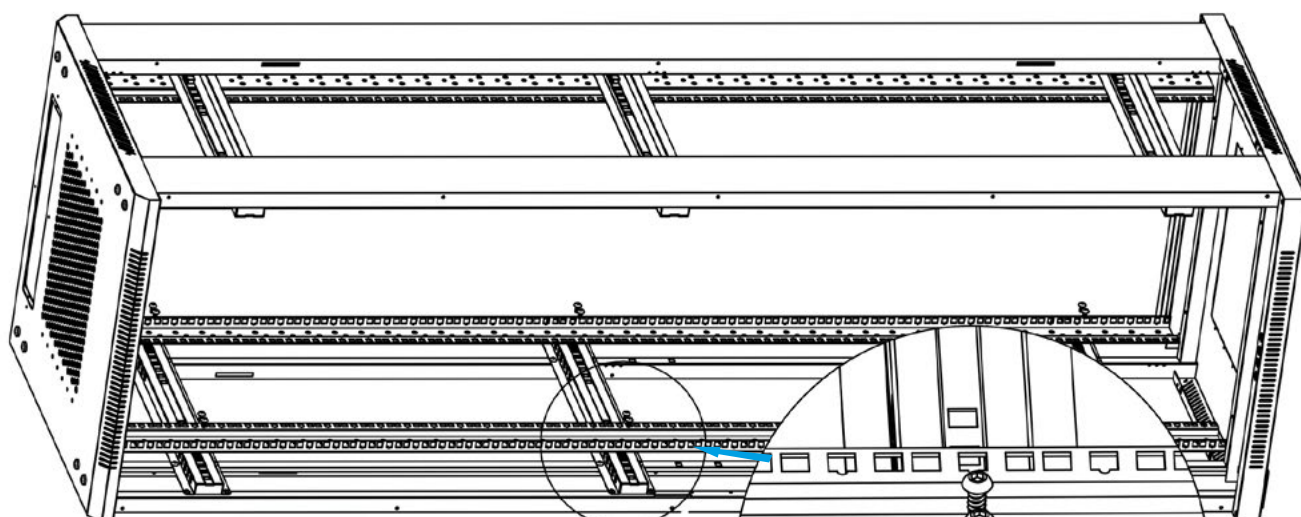

Śruba imbusowa M6
(element U)

Krok 6. Przygotuj śruby montażowe M6 (element U). Użyj śrub do zamocowania pionowych szyn montażowych (element I) do poziomych listew poprzecznych (element G).

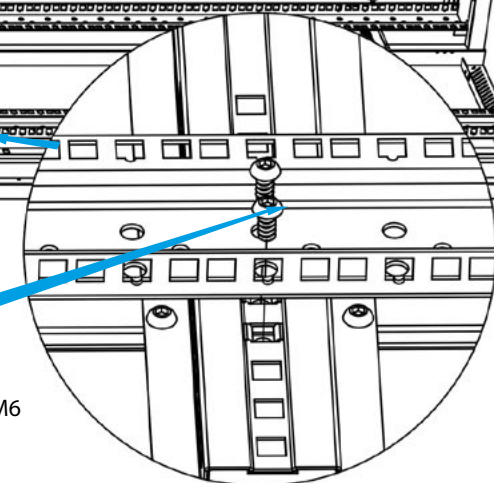

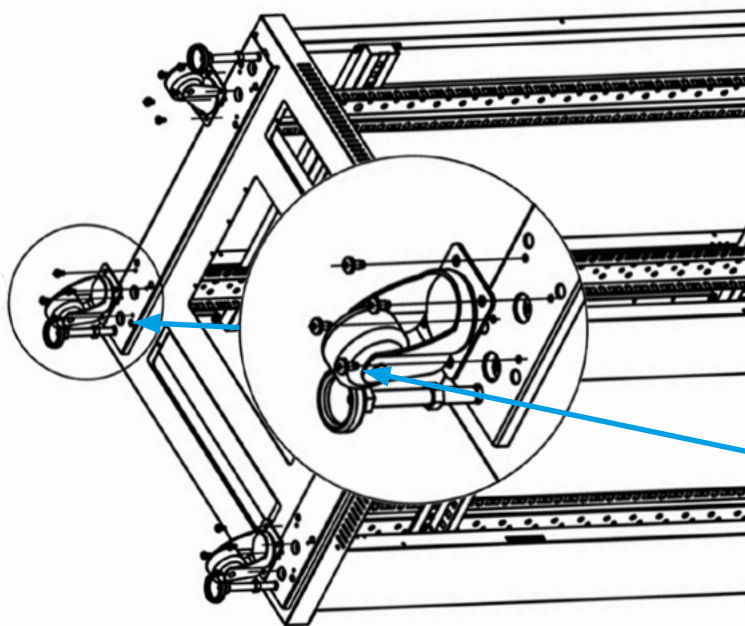

Krok 7. Przygotuj śruby samogwintujące M5 (element R), aby zamocować cztery kółka (element L) na pokrywie dolnej (element F). Również do tej samej pokrywy zamontuj regulowane nożki (element K).



Śruba samogwintująca M5 (element R)

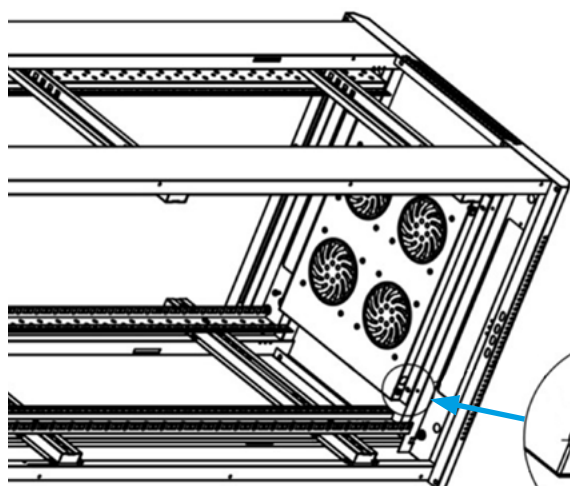

Krok 8. Do zamontowania półki wentylatora (element H) do ramy (część D), użyj wkrętu samogwintującego M5 (element R).



Śruba samogwintująca M5 (element R)

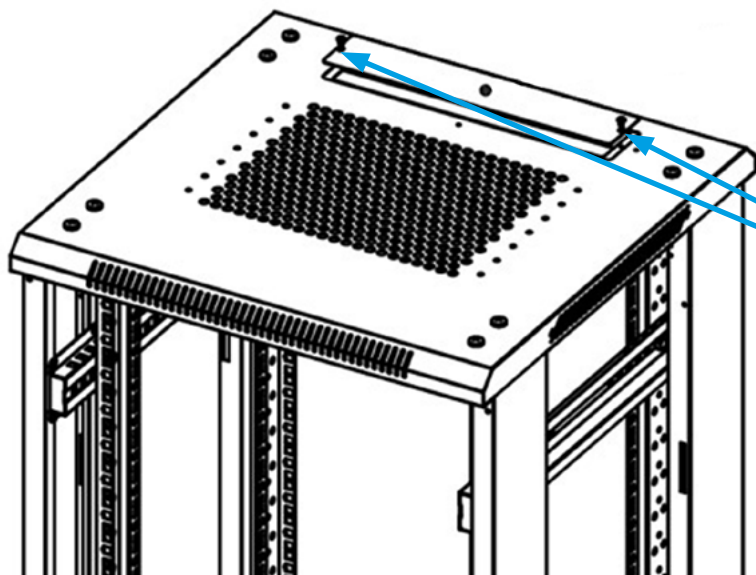

Krok 9. Przygotuj śruby samogwintujące M4 (element S) oraz użyj ich do zamocowania zaślepki panelu górnego (element J).



Śruba samogwintująca M4 (element S)

Krok 10. Przygotuj wkręty samogwintujące M4 (element S), za pomocą których zamocuj stopery do drzwi (element M). Dla rozmiarów 15U~27U (8 szt.), 32U~47U (12 szt.).



Śruba samogwintująca
M4 (element S)

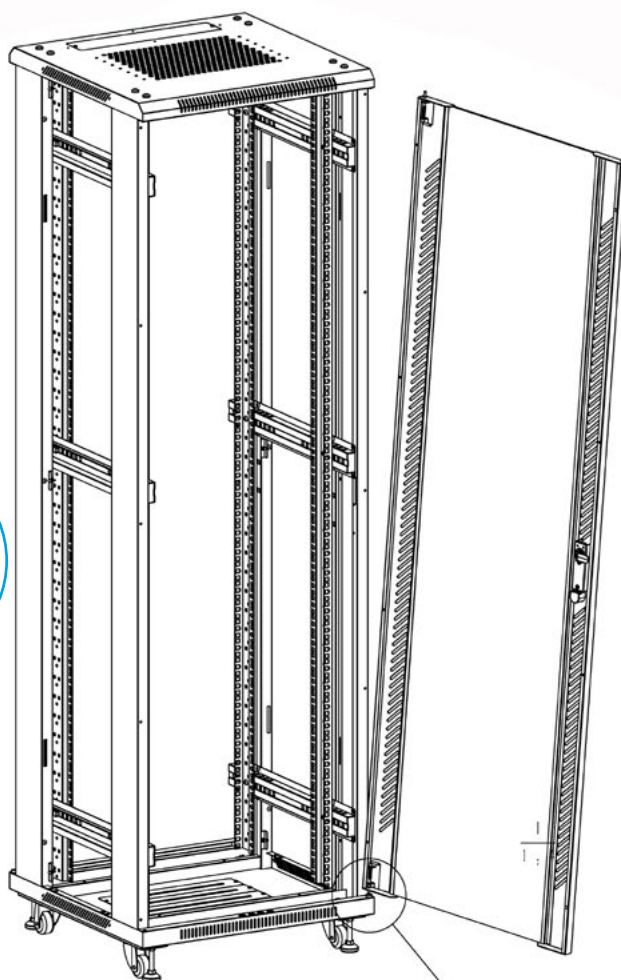
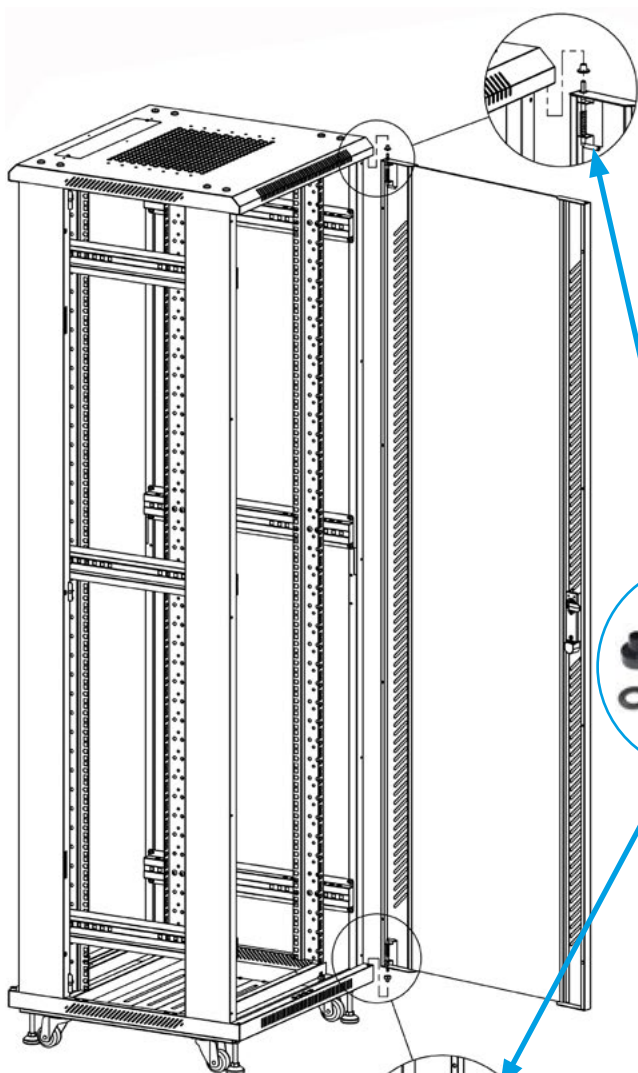
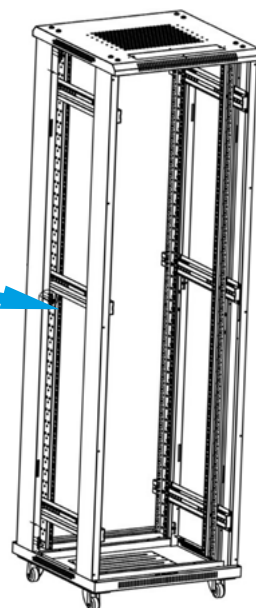
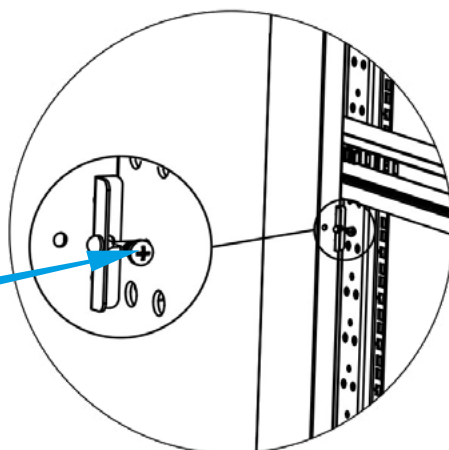

Krok 11. Przygotuj i umieść w odpowiednim miejscu dystanse (element W) dla drzwi przednich oraz panelu tylnego (element A i B). Boczne panele (element C) zamontuj w ostatnim etapie.











1. Návod k montáži





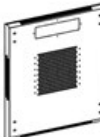
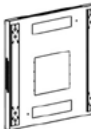

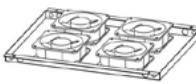
i Dbejte na důsledné dodržování pokynů v tomto manuálu.

1.1 Příprava

Připravte dostatek volného prostoru na povrchu, na kterém bude montáž probíhat. Opatrně vyjměte všechny součásti z přepravní krabice. Další montážní pokyny budou vycházet z uvedeného schématu

1.1.1. Tabulka příslušenství

| Díly rozvaděče | | | | |
|----------------|------------------------|---|--------------------------------|--------------|
| Č. položky | Název položky | Výkres položky | Požadovaný počet | Počet v sadě |
| Položka A | Přední skleněné dveře |  | 1 ks | 1 ks |
| Položka B | Zadní panel |  | 1 ks | 1 ks |
| Položka C | Boční panely |  | 2 ks | 2 ks |
| Položka D | Rám |  | 2 ks | 2 ks |
| Položka E | Horní kryt |  | 1 ks | 1 ks |
| Položka F | Spodní kryt |  | 1 ks | 1 ks |
| Položka G | Příčník |  | 15U~27U 4 ks 32U~42U 6 ks | |
| Položka H | Police pro ventilátory |  | 1 ks | 1 ks |
| Položka I | Montážní lišty |  | 4 ks | 4 ks |
| Položka J | Krytka horního panelu |  | Ploché 3 ks Drážkovaný 4 ks | |

| | | | | |
|-----------|--------------------------|--|-------------------------------|------|
| Položka K | Nastavitelné nožičky |  | 4 ks | 4 ks |
| Položka L | Kolečka s brzdou |  | 4 ks | 4 ks |
| Položka M | Dveřní dorazy |  | 15U~27U 8 ks 32U~42U 12 ks | |
| Položka N | Zámek předních dveří |  | 1 ks | 1 ks |
| Položka O | Zámek zadního panelu |  | 3 ks | 3 ks |
| Položka W | Distanční podložky dveří |  | 2 ks | 4 ks |

| Šrouby | | | | |
|------------|----------------------------|---|------------------|--------------|
| Č. položky | Název položky | Výkres položky | Požadovaný počet | Počet v sadě |
| Položka Q | Imbusový šroub M8 |  | 16 ks | 17 ks |
| Položka R | Samořezné šrouby M5*10 |  | 15U~27U 36 ks | 40 ks |
| | | | 32U~42U 44 ks | 50 ks |
| Položka S | Samořezné šrouby M4*8 |  | 15U~27U 20 ks | 23 ks |
| | | | 32U~42U 26 ks | 30 ks |
| Položka T | Klecová matice M6 |  | 15U~27U 32 ks | 35 ks |
| | | | 32U~42U 48 ks | 50 ks |
| Položka U | Imbusový šroub M6x12 |  | 15U~27U 32 ks | 35 ks |
| | | | 32U~42U 48 ks | 52 ks |
| Položka V | Přídavný šroub a matice M6 |  | 20 ks | 20 ks |

2. Etapy montáže

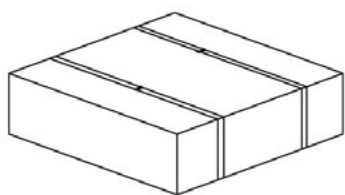

HORNÍ A SPODNÍ BALENÍ 1/3

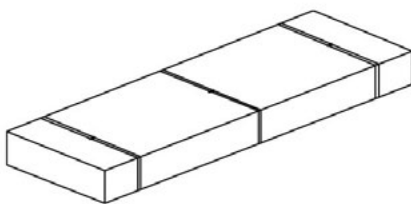

PŘEDNÍ DVEŘE, ZADNÍ PANEĽ
A BOČNÍ PANEĽY 2/3

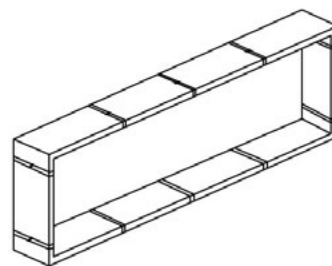

BALENÍ RÁMU 3/3

Krok 1. Vyměte zámek předních dveří (položka N), zámky bočních panelů a zámek zadního panelu (položka O); komponenty jsou v balení 1/3. Poté vyjměte přední skleněné dveře (položka A), zadní panel (položka B) a boční panely (položka C) z balení 2/3. V této fázi začneme montáží zámků na výše uvedené komponenty.



Krok 2. Vybalte části rámu (položka J) z balení 3/3. Poté uspořádejte rámy rovnoběžně vedle sebe tak, aby čtvercové otvory směřovaly dovnitř. Spodní část rámu poznáte podle prvku pro instalaci uzemnění.

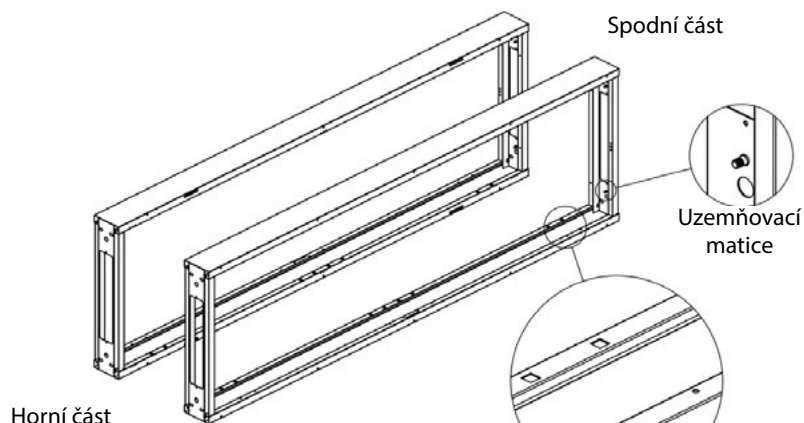

Krok 3. Nasadte horní kryt (položka E) na horní část rámu (položka D) a poté je spojte imbusovým šroubem M8 (položka Q) dohromady.

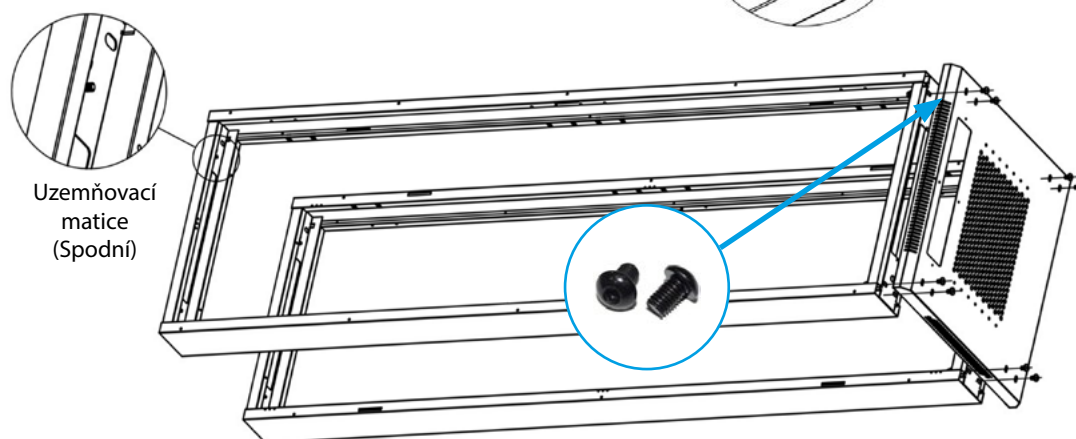

Krok 4. Nasadte spodní kryt (položka F) na spodní část rámu (položka D) a poté je spojte imbusovým šroubem M8 (položka Q).

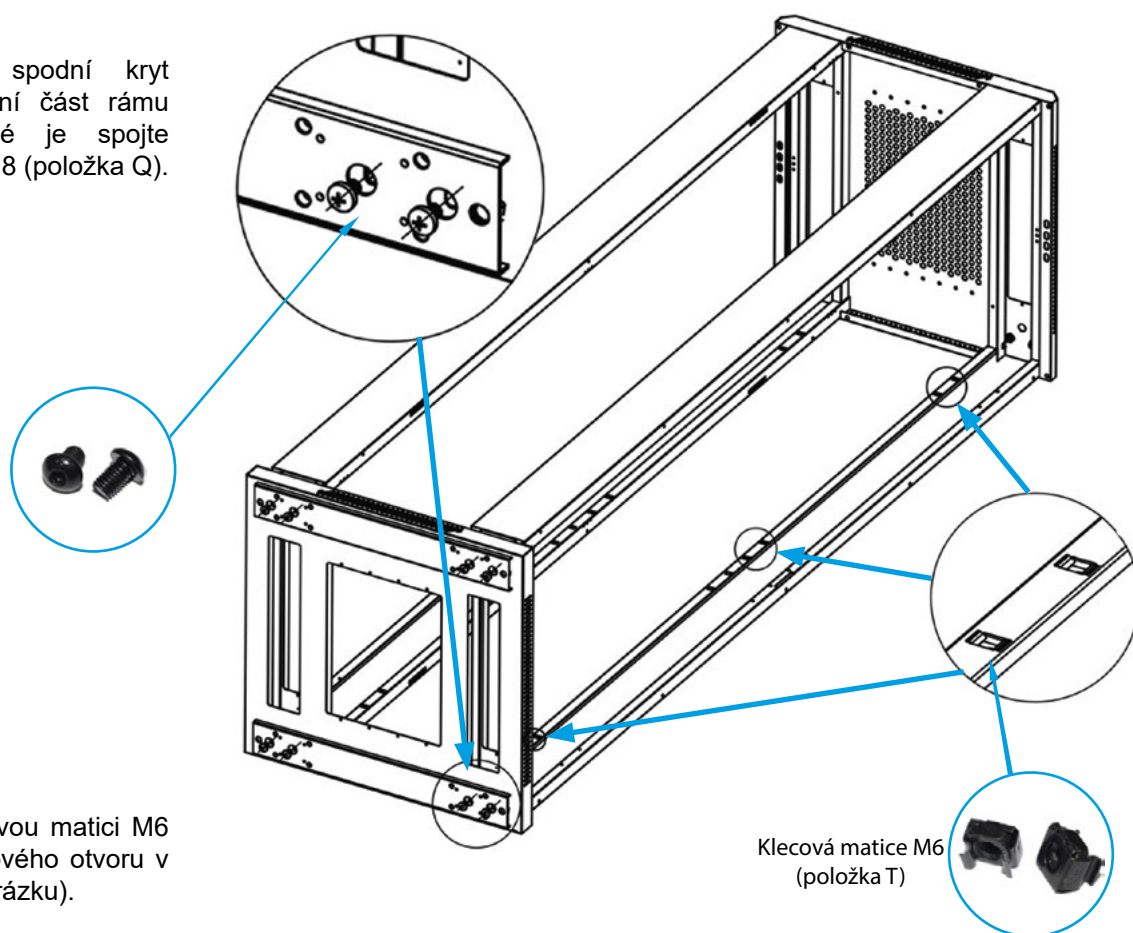

Krok 4a. Vložte klecovou matici M6 (položka T) do čtvercového otvoru v rámu (označeno na obrázku).

Klecová matice M6 (položka T)

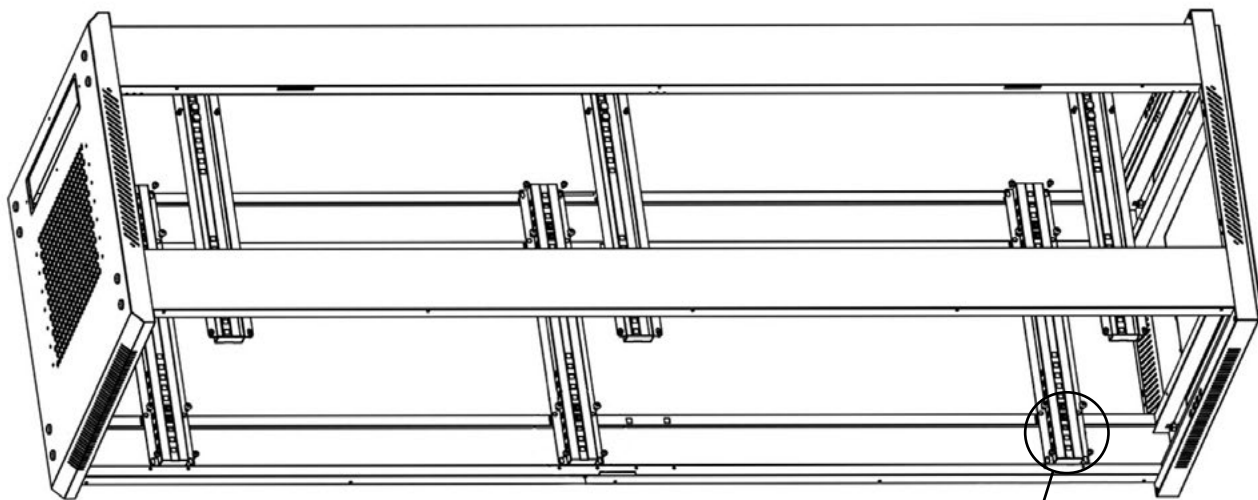

Imbusový šroub M6
(položka U)

Samořezný šroub M5
(položka R)

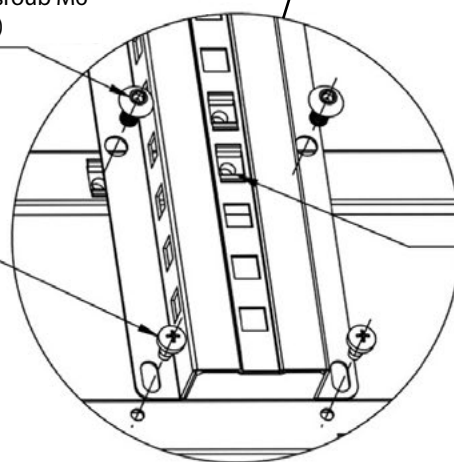

Klecová matice M6
(položka T)

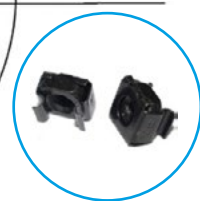

Krok 5. Připravte klecové matice M6 (položka T) a upevněte je na příčník (položka G), poté umístěte příčník na rám (položka D) tak, aby se vyhnul uzamykacímu otvoru v rámu. K upevnění příčníku použijte imbusový šroub M6 (položka U) a samořezný šroub M5 (položka R).

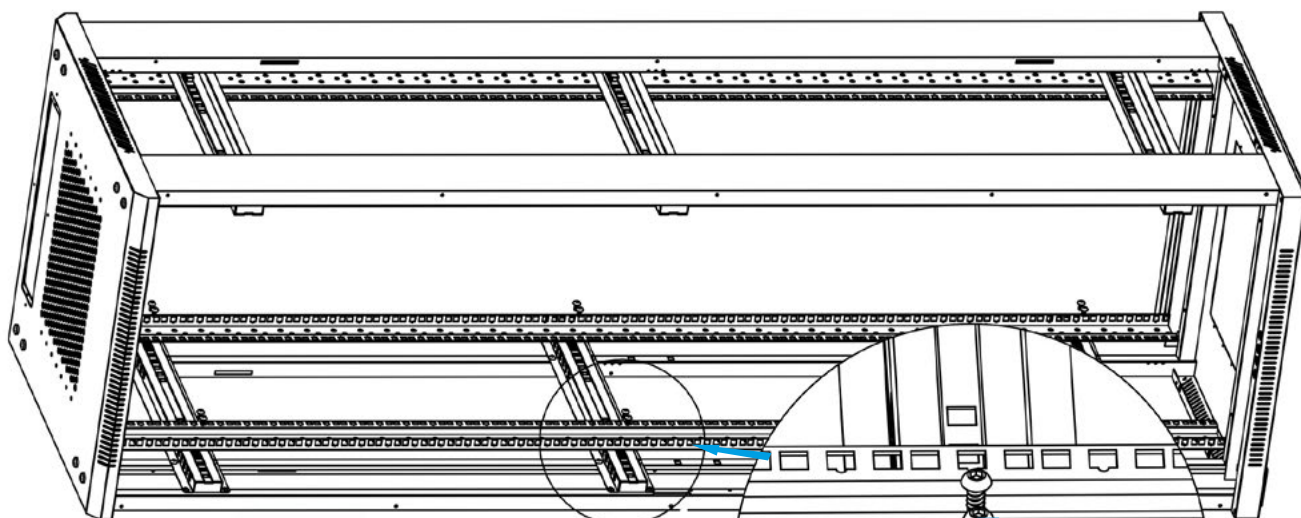

Imbusový šroub M6
(položka U)

Krok 6. Připravte montážní šrouby M6 (položka U). Pomocí šroubů připevněte svislé montážní lišty (položka I) k vodorovným příčníkům (položka G).

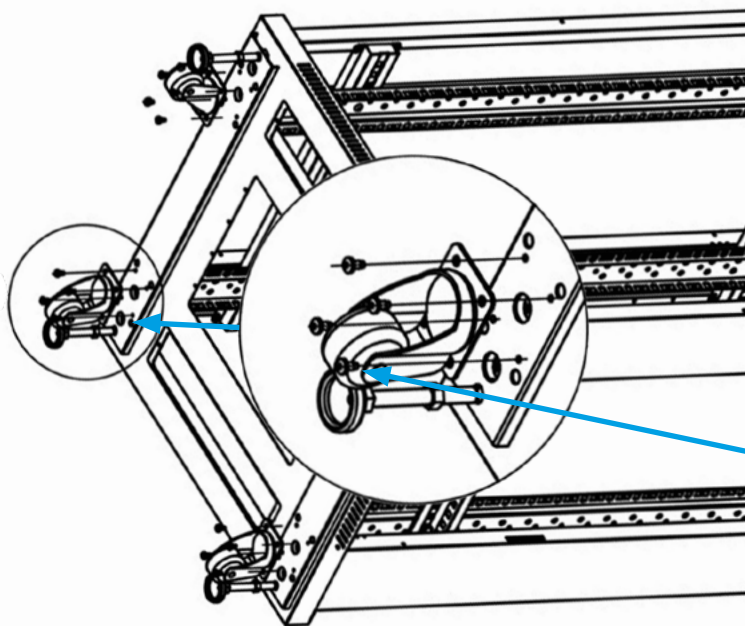

Krok 7. Připravte samořezné šrouby M5 (položka R) k upevnění čtyř koleček s brzdou (položka L) na spodní kryt (položka F). Poté připevněte nastavitelné nožičky (položka K) na spodní kryt.



Samořezný šroub M5 (položka R)

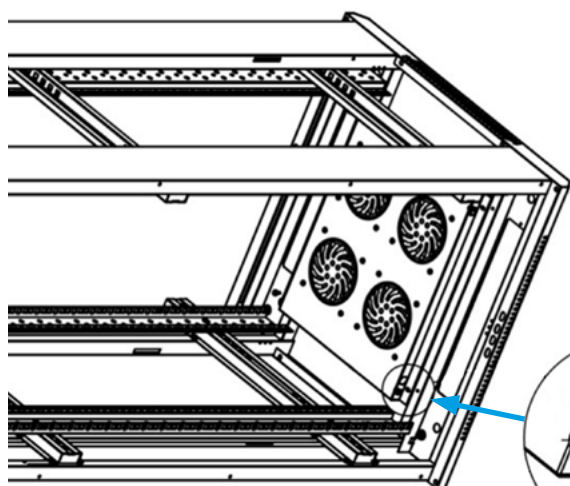

Krok 8. Připravte samořezné šrouby M5 (položka R) a použijte je k připevnění police pro ventilátory (položka H) k rámu RACK (položka D).



Samořezný šroub M5 (položka R)

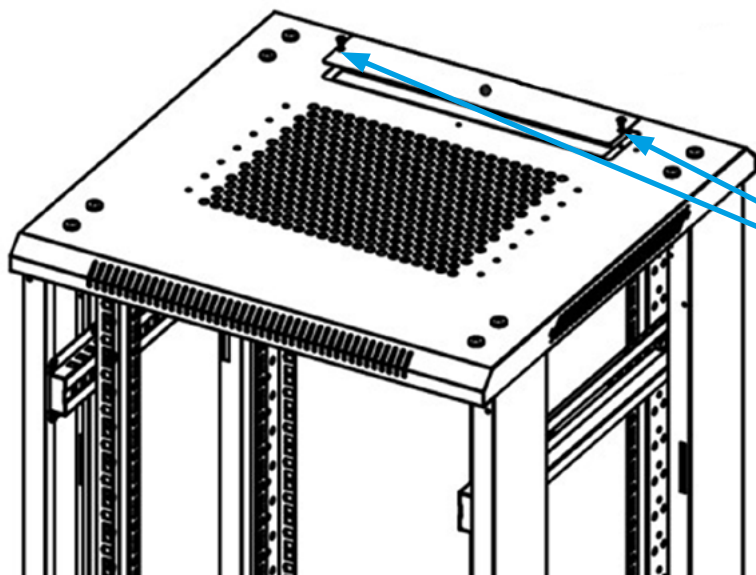

Krok 9. Připravte a použijte samořezný šroub M4 (položka S) k připevnění krytky horního panelu (položka J).



Samořezný šroub M4 (položka S)

Krok 10. Připravte a použijte samořezné šrouby M4 (položka S) k upevnění dveřních dorazů (položka M). Pro velikosti 15U~27U (8 ks), 32U~47U (12 ks).



Samořezný šroub M4
(položka S)

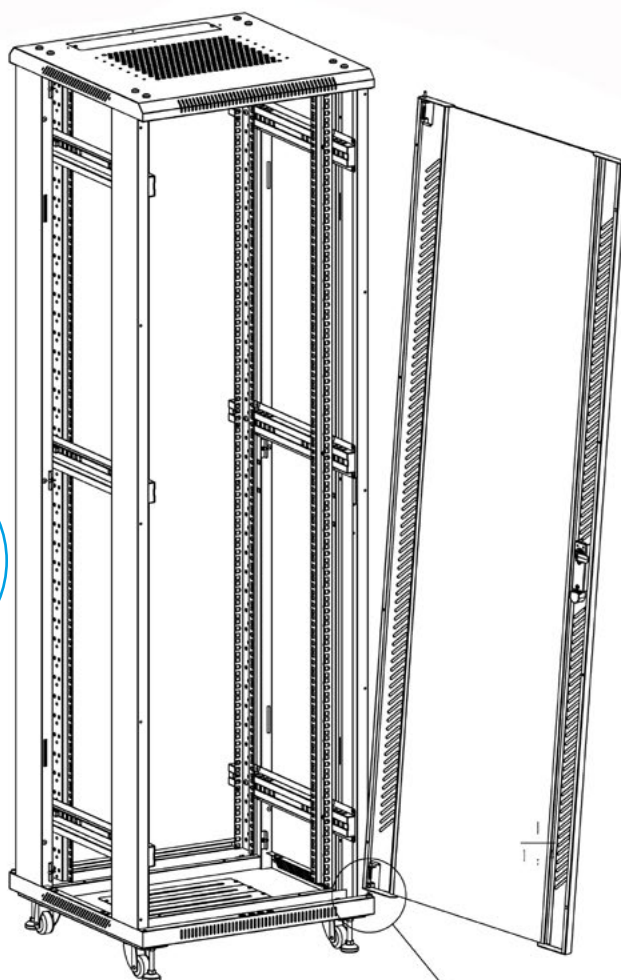
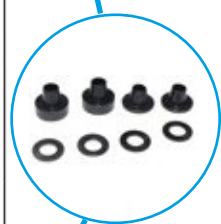
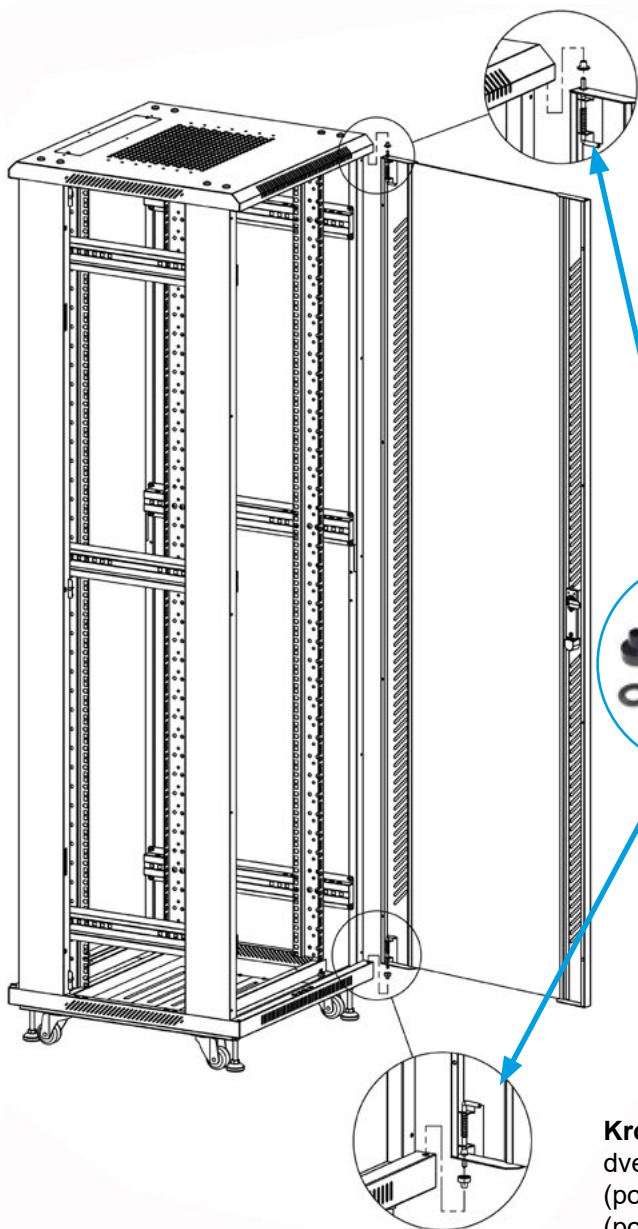
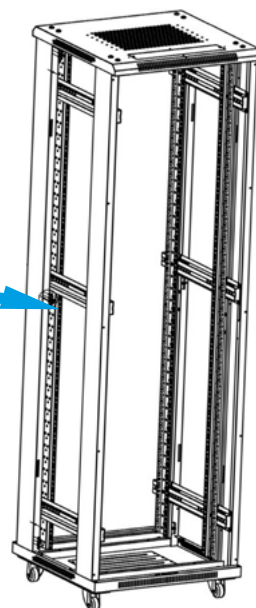
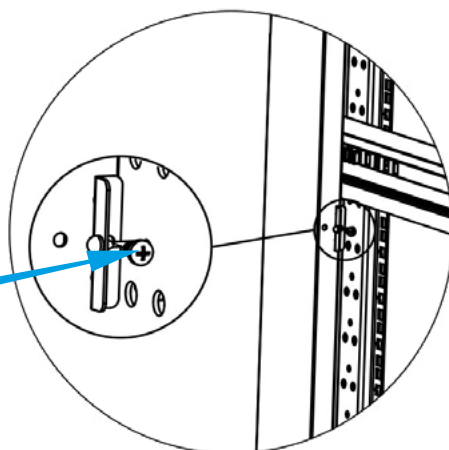

Krok 11. Připravte a umístěte distanční podložky dveří (položka W) pro přední dveře a zadní panel (položky A a B) na příslušná místa. Boční panely (položka C) namontujte až úplně nakonec.











1. Návod na montáž





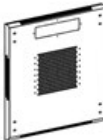
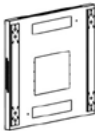

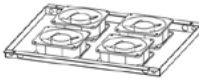
i Dbajte na dôsledné dodržiavanie pokynov v tomto manuáli.





1.1 Príprava

Prípravte dostatočné množstvo voľného priestoru na povrchu, na ktorom bude prebiehať montáž. Opatrne vyberte všetky súčasti z prepravnej krabice. Ďalšie montážne pokyny budú vychádzať z uvedeného diagramu

1.1.1. Tabuľka príslušenstva

| Časti skrine | | | | |
|--------------|------------------------|---|--------------------------------|--------------|
| Č. položky | Názov položky | Výkres položky | Požadovaný počet | Počet v sade |
| Položka A | Predné sklenené dvere |  | 1 ks | 1 ks |
| Položka B | Zadný panel |  | 1 ks | 1 ks |
| Položka C | Bočné panely |  | 2 ks | 2 ks |
| Položka D | Rám |  | 2 ks | 2 ks |
| Položka E | Horný kryt |  | 1 ks | 1 ks |
| Položka F | Spodný kryt |  | 1 ks | 1 ks |
| Položka G | Priečnik |  | 15U~27U 4 ks 32U~42U 6 ks | |
| Položka H | Polica pre ventilátory |  | 1 ks | 1 ks |
| Položka I | Montážne lišty |  | 4 ks | 4 ks |
| Položka J | Krytka horného panelu |  | Plochý 3 ks Drážkovaný 4 ks | |

| | | | | |
|-----------|--------------------------|--|-------------------------------|------|
| Položka K | Nastavitelné nožičky |  | 4 ks | 4 ks |
| Položka L | Kolieska s brzdou |  | 4 ks | 4 ks |
| Položka M | Dorazy dveří |  | 15U~27U 8 ks 32U~42U 12 ks | |
| Položka N | Zámek předných dveří |  | 1 ks | 1 ks |
| Položka O | Zámek zadného panelu |  | 3 ks | 3 ks |
| Položka W | Dištančné podložky dveří |  | 2 ks | 4 ks |

| Skrutky | | | | |
|------------|-------------------------------|---|------------------|--------------|
| Č. položky | Název položky | Výkres položky | Požadovaný počet | Počet v sade |
| Položka Q | Imbusová skrutka M8 |  | 16 ks | 17 ks |
| Položka R | Samorezné skrutky M5*10 |  | 15U~27U 36 ks | 40 ks |
| | | | 32U~42U 44 ks | 50 ks |
| Položka S | Samorezné skrutky M4*8 |  | 15U~27U 20 ks | 23 ks |
| | | | 32U~42U 26 ks | 30 ks |
| Položka T | Klietková matica M6 |  | 15U~27U 32 ks | 35 ks |
| | | | 32U~42U 48 ks | 50 ks |
| Položka U | Imbusová skrutka M6x12 |  | 15U~27U 32 ks | 35 ks |
| | | | 32U~42U 48 ks | 52 ks |
| Položka V | Doplňková skrutka a matica M6 |  | 20 ks | 20 ks |

2. Etapy montáže

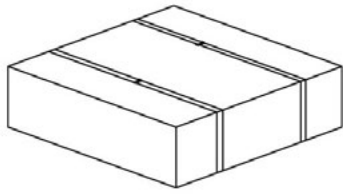

**HORNÉ A SPODNÉ
BALENIE 1/3**

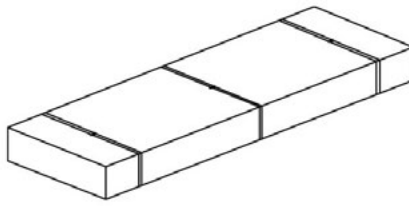

**PREDNÉ DVIERKA, ZADNÝ
PANEL A BOČNÉ PANELE 2/3**

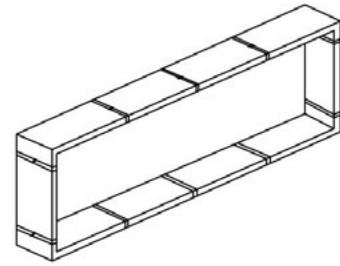

BALENIE RÁMU 3/3

Krok 1. Vyberte zámok predných dverí (položka N), zámky bočných panelov a zámok zadného panelu (položka O); komponenty sú v balení 1/3. Potom vyberte predné sklenené dvere (položka A), zadný panel (položka B) a bočné panely (položka C) z balenia 2/3. V tejto fáze začneme montážou zámkov na vyššie uvedené komponenty.



Krok 2. Vybalte časti rámu (položka J) z balenia 3/3. Potom usporiadajte rámy rovnobežne vedľa seba tak, aby štvorcové otvory smerovali dovnútra. Spodnú časť rámu spoznáte podľa prvku na inštaláciu uzemnenia.

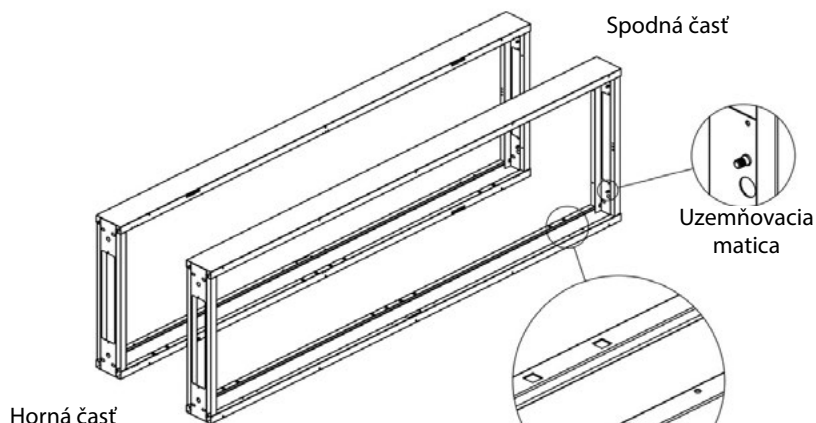

Krok 3. Nasadte horný kryt (položka E) na hornú časť rámu (položka D) a potom ich spojte imbusovou skrutkou M8 (položka Q) dohromady.

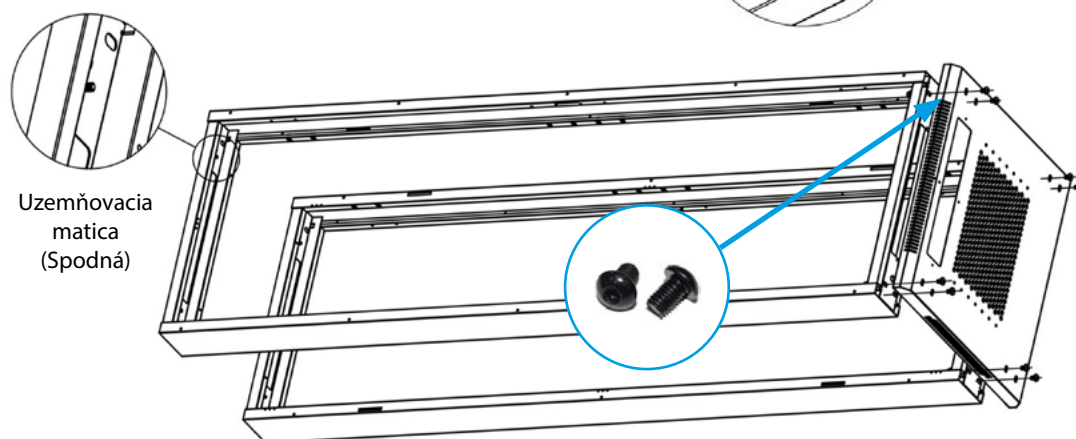

Krok 4. Nasadte spodný kryt (položka F) na spodnú časť rámu (položka D) a potom ich spojte imbusovou skrutkou M8 (položka Q).

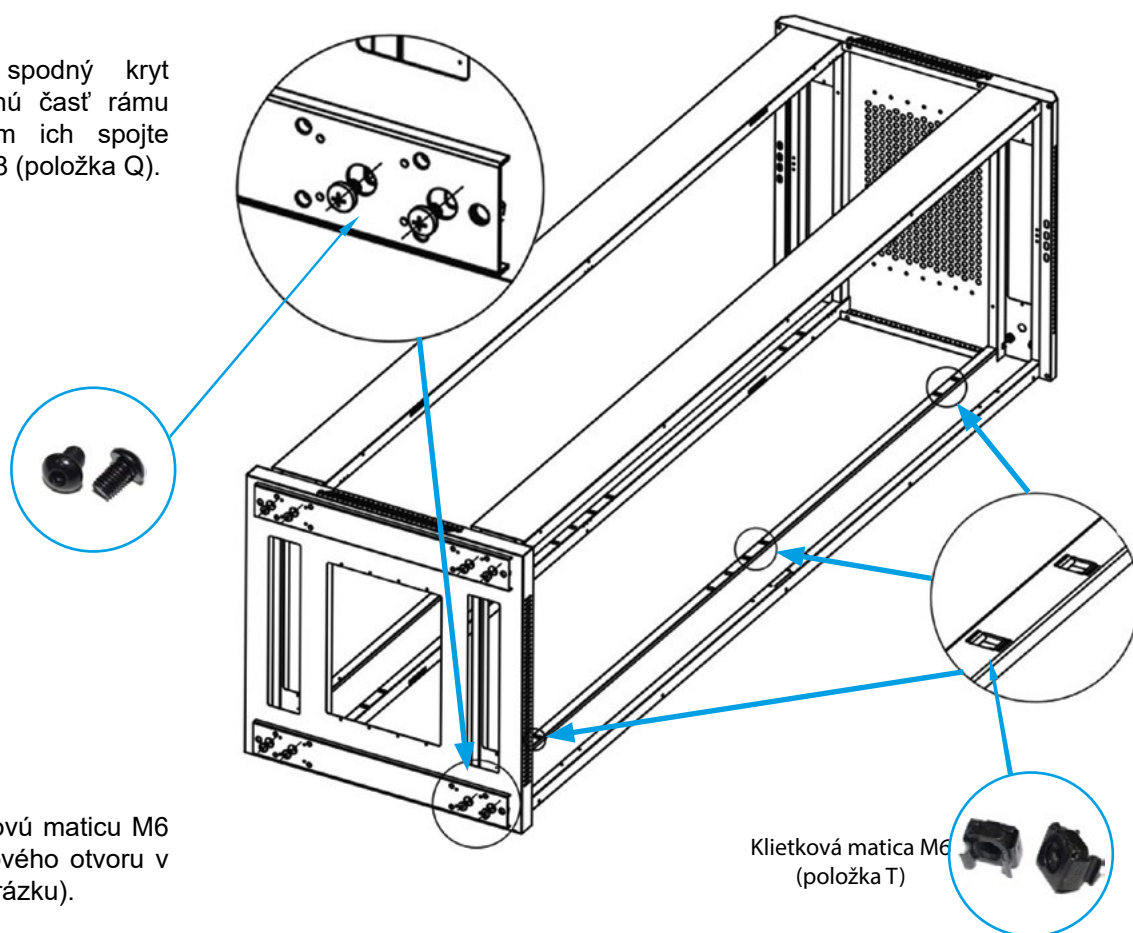

Krok 4a. Vložte klietkovú maticu M6 (položka T) do štvorcového otvoru v ráme (označené na obrázku).

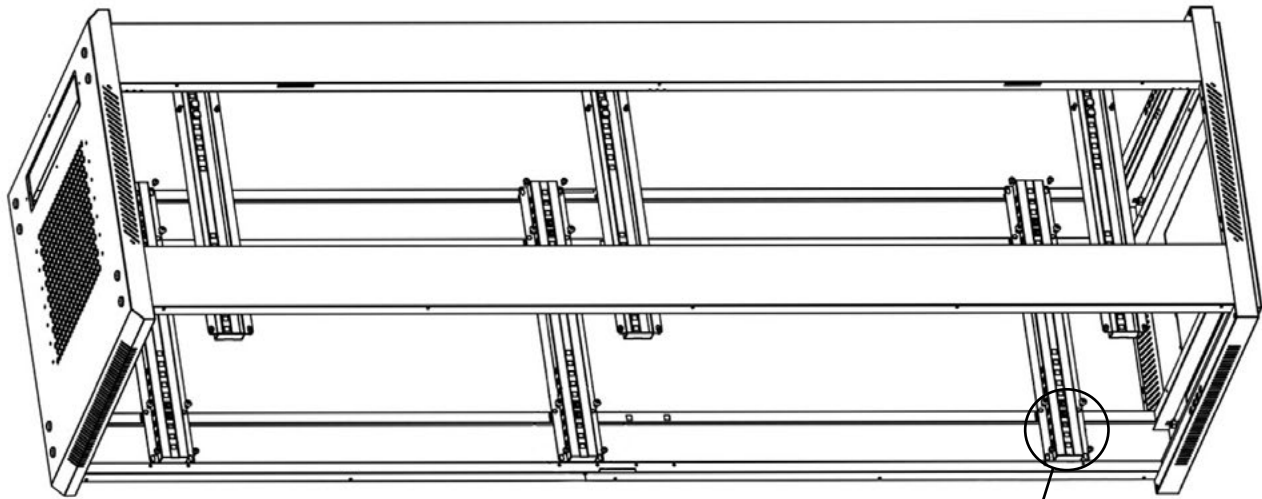

Krok 5. Pripravte klieťkové matice M6 (položka T) a upevnite ich na priečnik (položka G), potom umiestnite priečnik na rám (položka D) tak, aby ste sa vyhli uzamykaciemu otvoru v ráme. Na upevnenie priečnika použite imbusovú skrutku M6 (položka U) a samoreznú skrutku M5 (položka R).



Imbusová skrutka M6 (položka U)

Samorezná skrutka M5 (položka R)

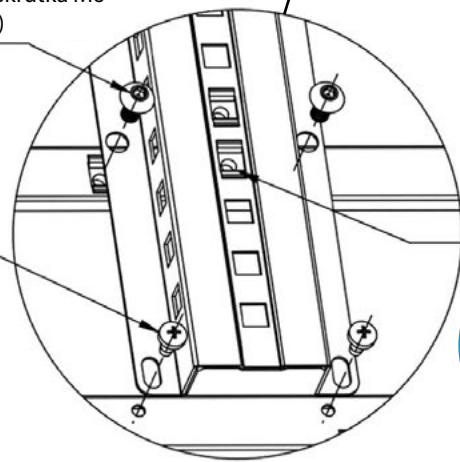

Klieťková matica M6 (položka T)

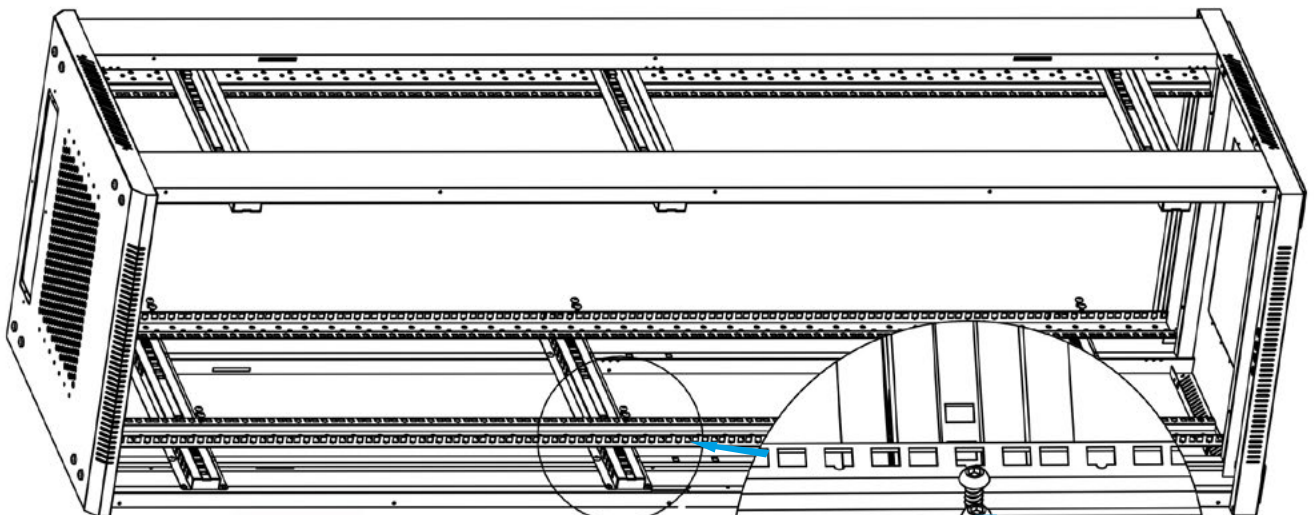

Krok 6. Pripravte montážne skrutky M6 (položka U). Pomocou skrutiek pripevnite zvislé montážne lišty (položka I) k vodorovným priečnikom (položka G).



Imbusová skrutka M6 (položka U)

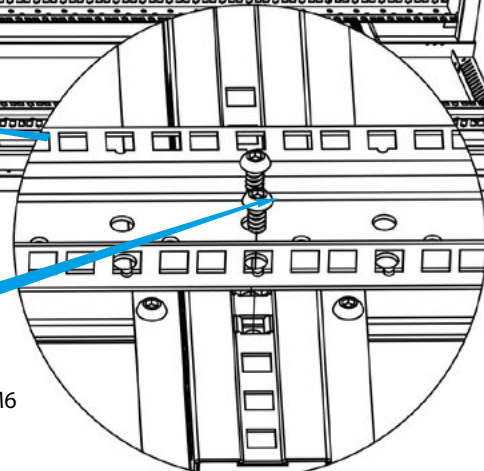

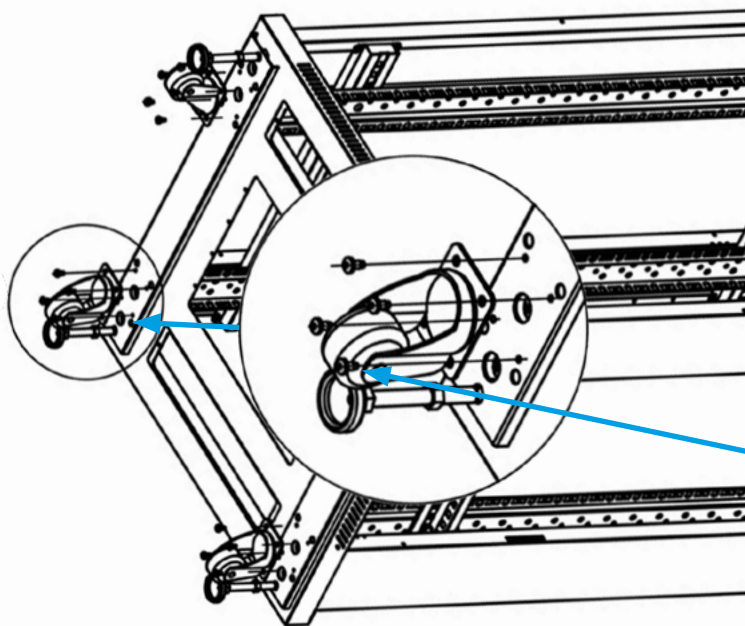

Krok 7. Pripravte samorezné skrutky M5 (položka R) na upevnenie štyroch koliesok s brzdou (položka L) na spodný kryt (položka F). Potom pripevnite nastaviteľné nožičky (položka K) na spodný kryt.



Samorezná skrutka M5 (položka R)

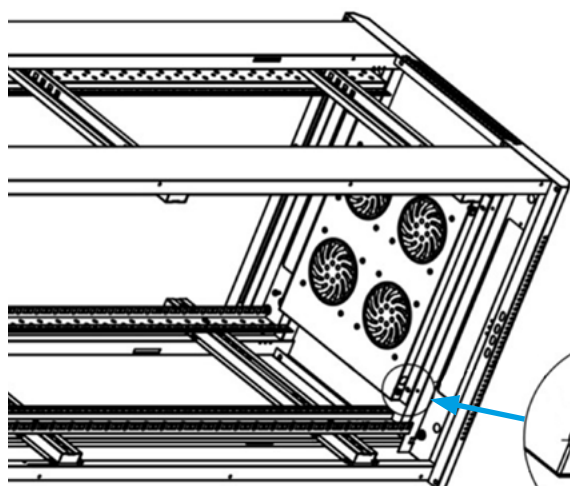

Krok 8. Pripravte samorezné skrutky M5 (položka R) a použite ich na pripevnenie police pre ventilátory (položka H) k rámu RACK (položka D).



Samorezná skrutka M5 (položka R)

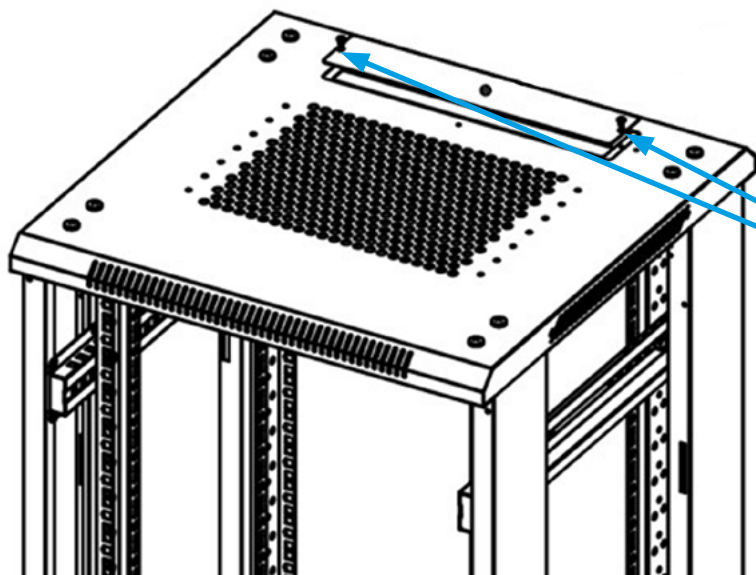

Krok 9. Pripravte a použite samoreznú skrutku M4 (položka S) na pripevnenie krytky horného panelu (položka J).



Samorezná skrutka M4 (položka S)

Krok 10. Pripravte a použite samorezné skrutky M4 (položka S) na upevnenie dorazov dverí (položka M). Pre veľkosti 15U~27U (8 ks), 32U~47U (12 ks).



Samorezná skrutka M4
(položka S)

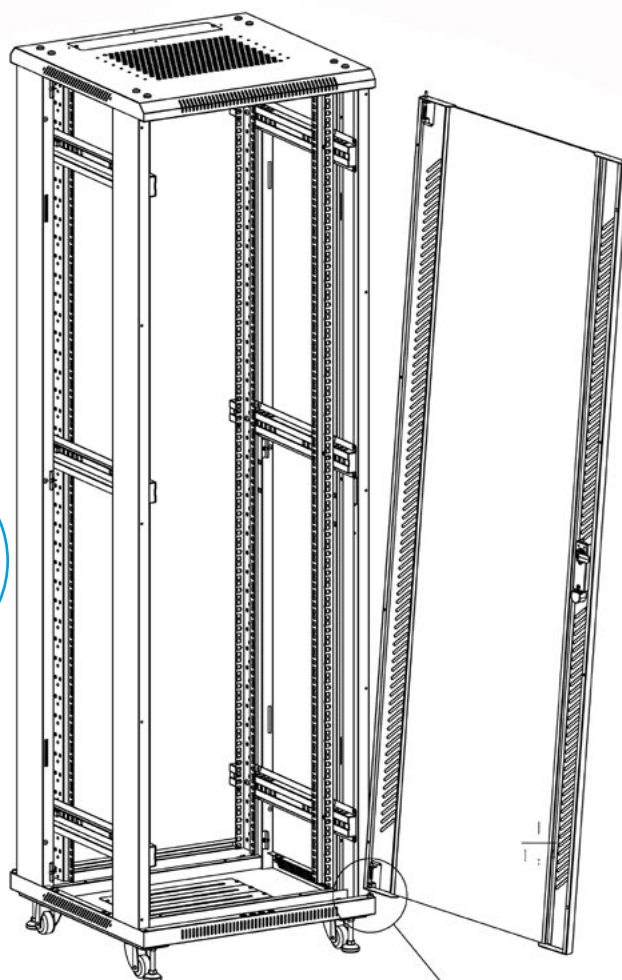
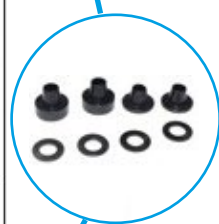
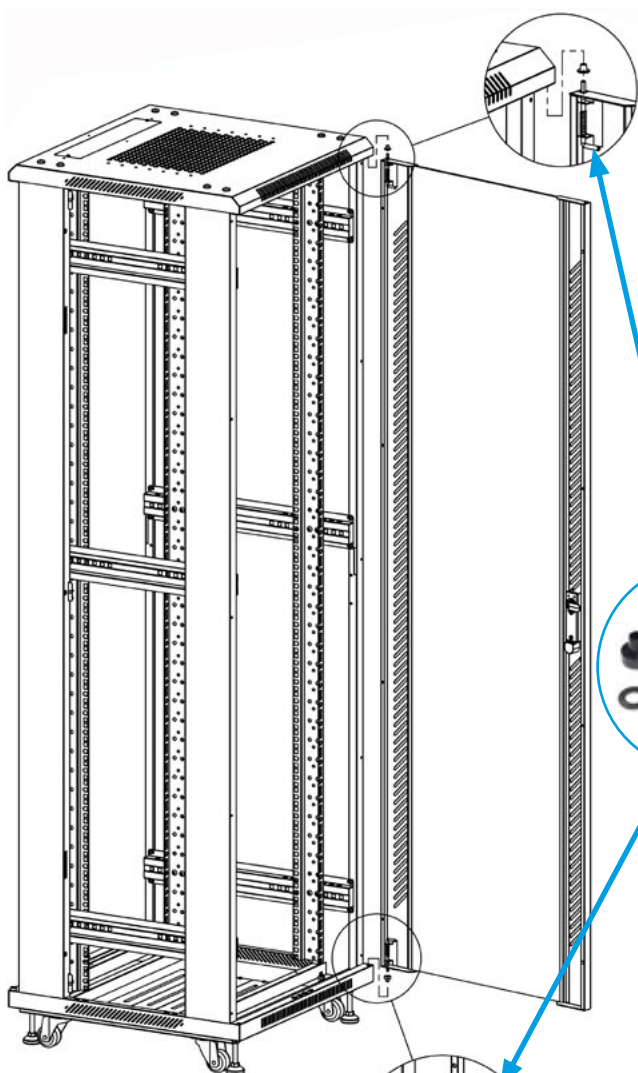
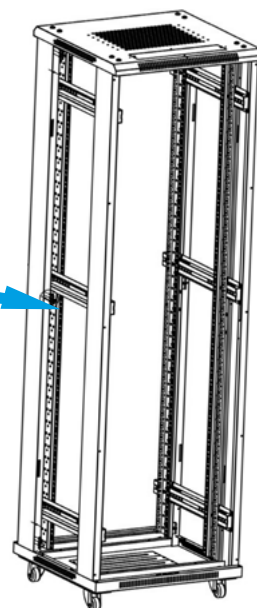
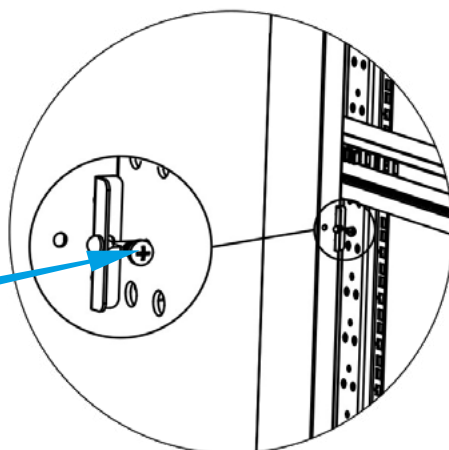

Krok 11. Pripravte a umiestnite dištančné podložky dverí (položka W) pre predné dvere a zadný panel (položky A a B) na príslušné miesta. Bočné panely (položka C) namontujte až úplne nakoniec.











1. Instrucțiuni de asamblare





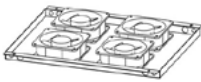

i Asigurați-vă că urmați cu strictețe instrucțiunile din acest manual.

1.1 Pregătire

Asigurați un spațiu liber adecvat pe suprafața pe care va avea loc asamblarea. Scoateți cu grijă toate elementele din cutia de transport. Instrucțiunile de asamblare următoare se vor baza pe diagrama furnizată

1.1.1. Tabel accesorii

| Piese dulap | | | | |
|-------------|----------------------------|---|----------------------------------|------------------|
| Nr. articol | Denumire articol | Desen articol | Cantitate necesară | Cantitate în set |
| Articol A | Ușă frontală din sticlă |  | 1 buc. | 1 buc. |
| Articol B | Panou spate |  | 1 buc. | 1 buc. |
| Articol C | Panouri laterale |  | 2 buc. | 2 buc. |
| Articol D | Cadru |  | 2 buc. | 2 buc. |
| Articol E | Capac superior |  | 1 buc. | 1 buc. |
| Articol F | Capac inferior |  | 1 buc. | 1 buc. |
| Articol G | Traversă |  | 15U~27U 4 buc. 32U~42U 6 buc. | |
| Articol H | Poliță pentru ventilatoare |  | 1 buc. | 1 buc. |
| Articol I | Șine de montaj |  | 4 buc. | 4 buc. |
| Articol J | Capac panou superior |  | Plat 3 buc. Striat 4 buc. | |

| | | | | |
|-----------|----------------------|--|-----------------------------------|--------|
| Articol K | Picioare reglabile |  | 4 buc. | 4 buc. |
| Articol L | Roți cu frână |  | 4 buc. | 4 buc. |
| Articol M | Opritoare ușă |  | 15U~27U 8 buc. 32U~42U 12 buc. | |
| Articol N | Broască ușă frontală |  | 1 buc. | 1 buc. |
| Articol O | Broască panou spate |  | 3 buc. | 3 buc. |
| Articol W | Distanțiere ușă |  | 2 buc. | 4 buc. |

| Șuruburi | | | | |
|-------------|----------------------------------|---|--------------------|------------------|
| Nr. articol | Denumire articol | Desen articol | Cantitate necesară | Cantitate în set |
| Articol Q | Șurub imbus M8 |  | 16 buc. | 17 buc. |
| Articol R | Șuruburi autofiletante M5*10 |  | 15U~27U 36 buc. | 40 buc. |
| | | | 32U~42U 44 buc. | 50 buc. |
| Articol S | Șuruburi autofiletante M4*8 |  | 15U~27U 20 buc. | 23 buc. |
| | | | 32U~42U 26 buc. | 30 buc. |
| Articol T | Piuliță tip cușcă M6 |  | 15U~27U 32 buc. | 35 buc. |
| | | | 32U~42U 48 buc. | 50 buc. |
| Articol U | Șurub imbus M6x12 |  | 15U~27U 32 buc. | 35 buc. |
| | | | 32U~42U 48 buc. | 52 buc. |
| Articol V | Șurub și piuliță suplimentare M6 |  | 20 buc. | 20 buc. |

2. Etapele de asamblare

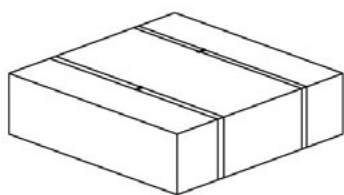

**PACHET SUPERIOR ȘI
INFERIOR 1/3**

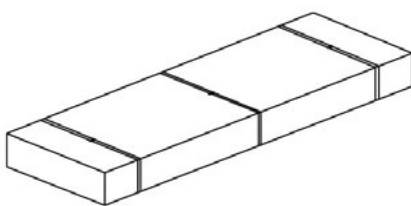

**UȘĂ FRONTALĂ, PANOU SPATE
ȘI PANOURI LATERALE 2/3**

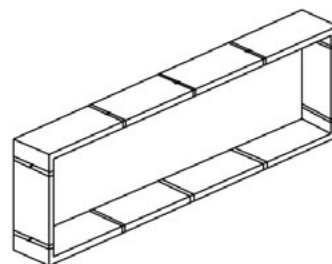

PACHET CADRU 3/3

Pas 1. Scoateți broasca ușii frontale (articol N), broaștele panourilor laterale și broasca panoului spate (articol O); componentele se află în pachetul 1/3. Apoi scoateți ușa frontală din sticlă (articol A), panoul spate (articol B) și panourile laterale (articol C) din pachetul 2/3. În această etapă începem prin montarea broaștelor pe componentele de mai sus.



Pas 2. Despachetați părțile cadrului (articol J) din pachetul 3/3. Apoi aranjați cadrele paralel unul cu celălalt, cu orificiile pătrate orientate spre interior. Puteți recunoaște partea inferioară a cadrului după elementul pentru instalarea împământării.

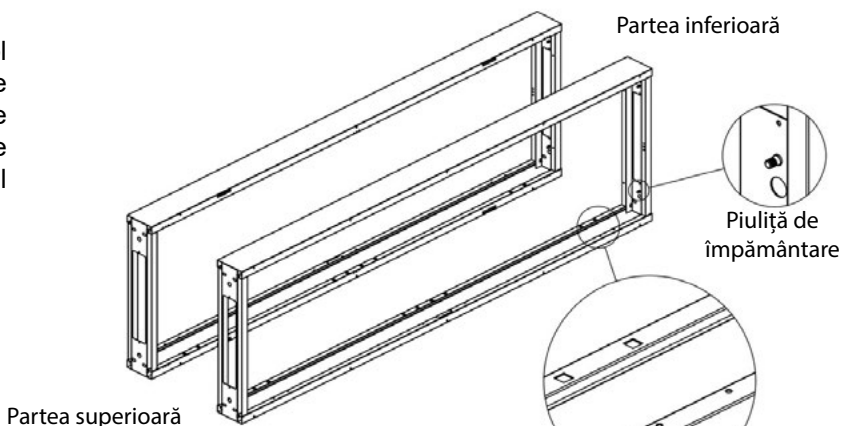

Pas 3. Montați capacul superior (articol E) pe partea superioară a cadrului (articol D), apoi folosiți un șurub imbus M8 (articol Q) pentru a le asambla împreună.

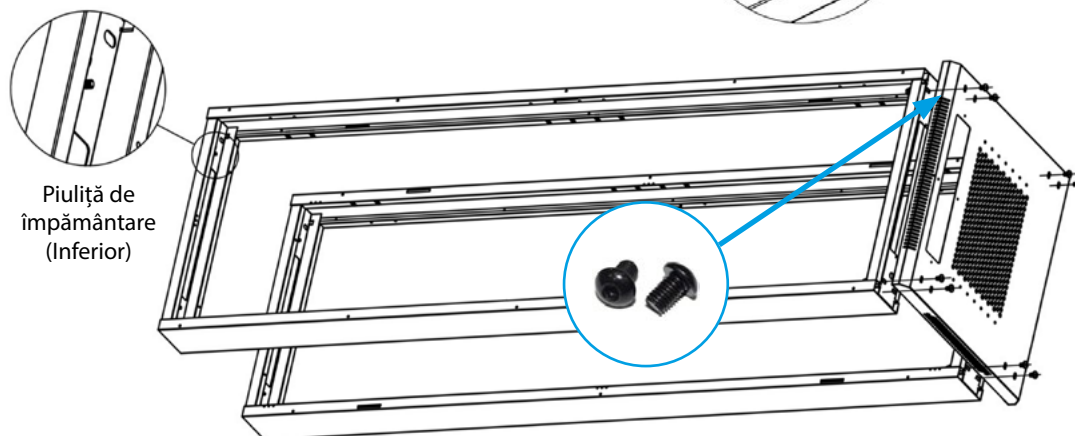

Pas 4. Montați capacul inferior (articol F) pe partea inferioară a cadrului (articol D) și apoi folosiți un șurub imbus M8 (articol Q) pentru a le îmbina.

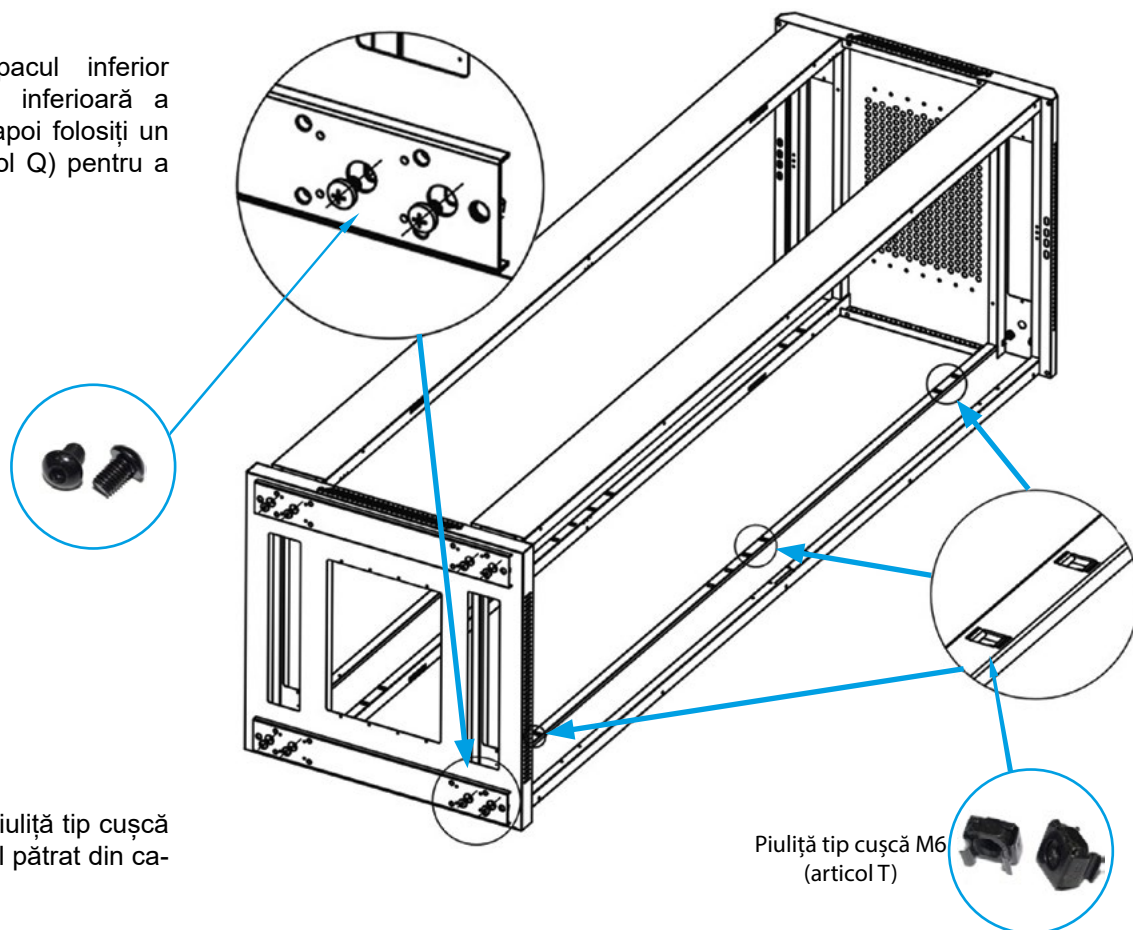

Pas 4a. Introduceți o piuliță tip cușcă M6 (articol T) în orificiul pătrat din cadru (indicat în figură).

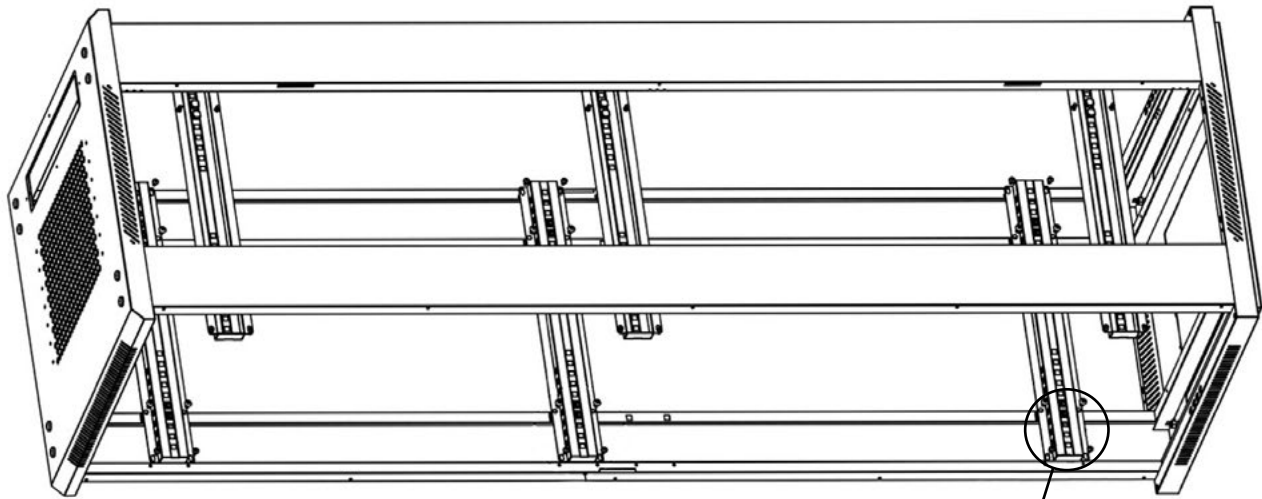

Șurub imbus M6
(articol U)

Pas 5. Pregătiți piulițele tip cușcă M6 (articol T) și fixați-le pe traversă (articol G), apoi așezați traversa pe cadru (articol D), evitând orificiul de blocare din cadru. Folosiți un șurub imbus M6 (articol U) și un șurub autofiletant M5 (articol R) pentru a fixa traversa.

Șurub autofiletant M5
(articol R)

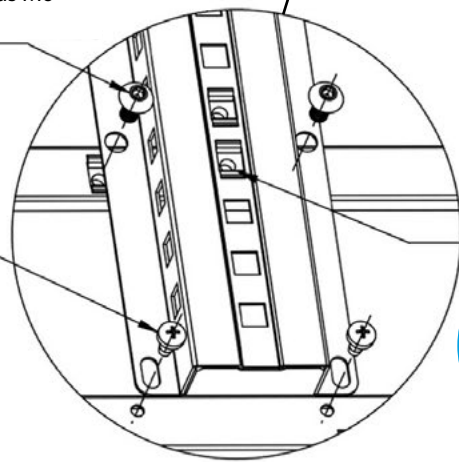

Piuliță tip
cușcă M6
(articol T)

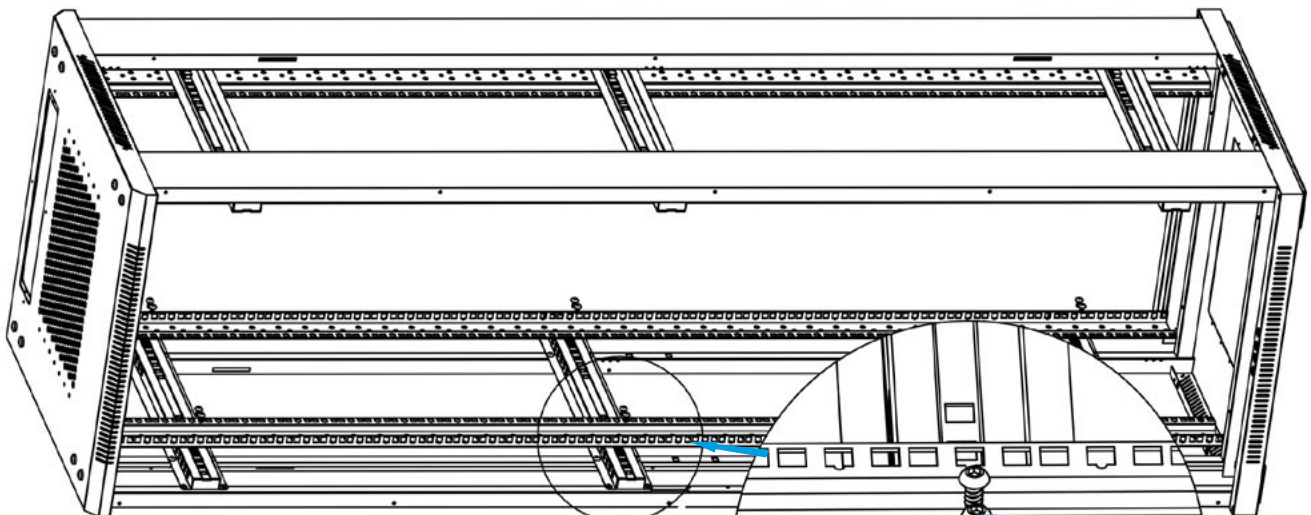

Pas 6. Pregătiți șuruburile de montaj M6 (articol U). Folosiți șuruburile pentru a fixa șinele verticale de montaj (articol I) pe traversele orizontale (articol G).



Șurub imbus M6
(articol U)

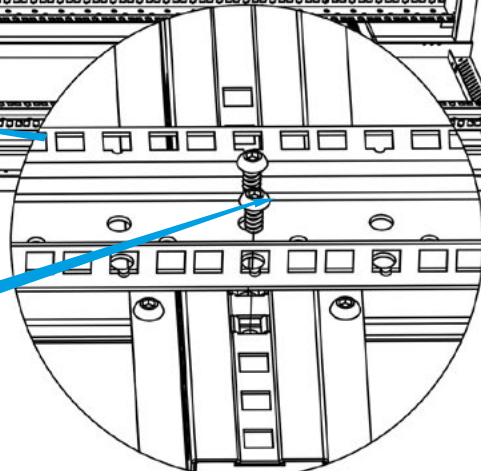

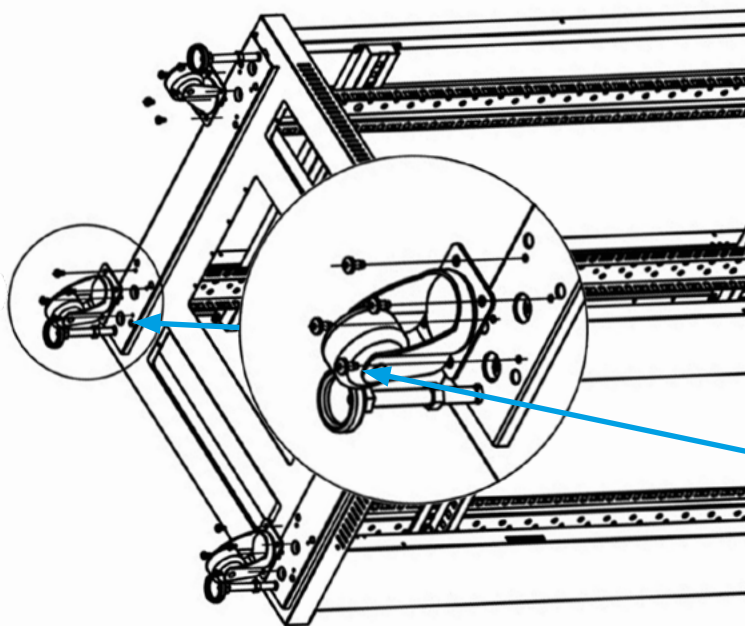

Pas 7. Pregătiți șuruburile autofiletante M5 (articol R) pentru a fixa cele patru roți cu frână (articol L) pe capacul inferior (articol F). Apoi montați picioarele reglabile (articol K) pe capacul inferior.



Șurub autofiletant M5 (articol R)

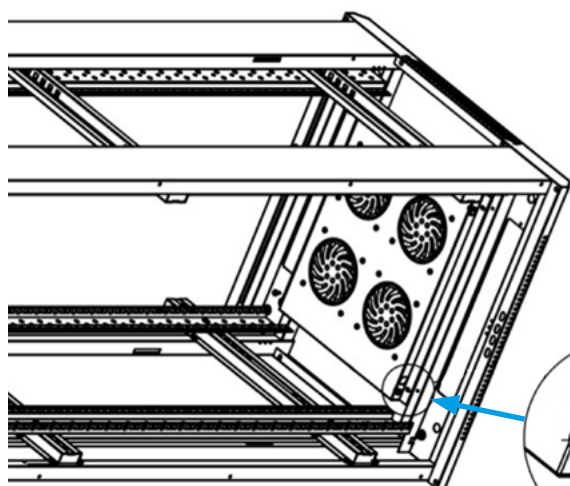

Pas 8. Pregătiți șuruburile autofiletante M5 (articol R), apoi folosiți-le pentru a fixa polița pentru ventilatoare (articol H) pe cadrul RACK (articol D).



Șurub autofiletant M5 (articol R)

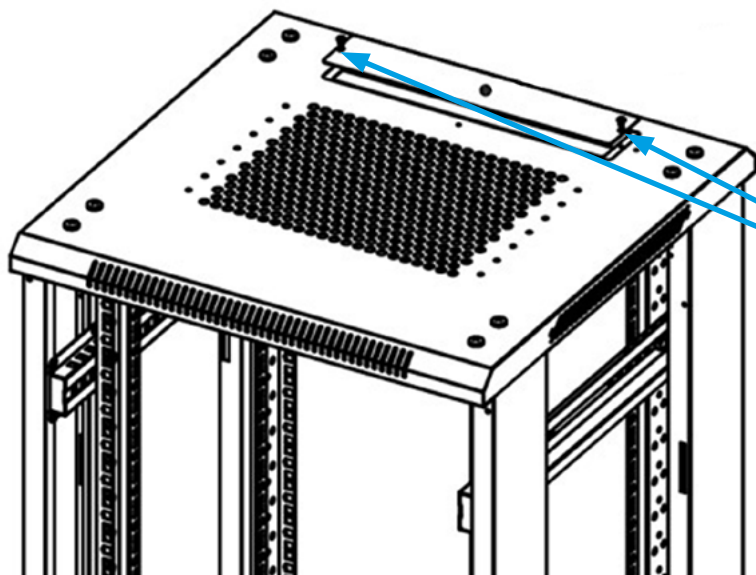

Pas 9. Pregătiți și utilizați un șurub autofiletant M4 (articol S) pentru a fixa capacul panoului superior (articol J).



Șurub autofiletant M4 (articol S)

Pas 10. Pregătiți și utilizați șuruburi autofiletante M4 (articol S) pentru a fixa opritoarele de ușă (articol M). Pentru dimensiuni 15U~27U (8 buc.), 32U~47U (12 buc.).



Șurub autofiletant M4
(articol S)

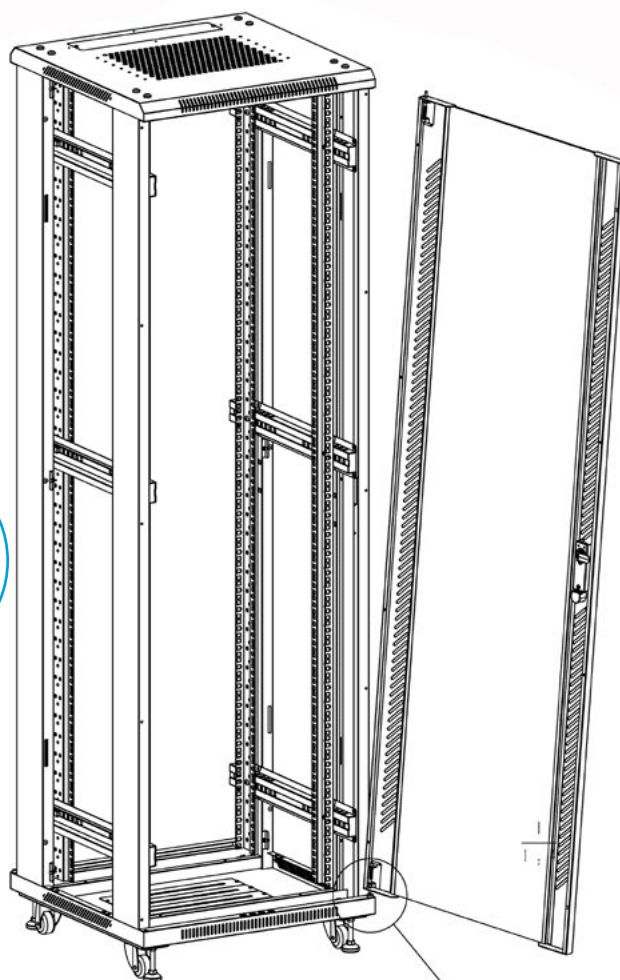
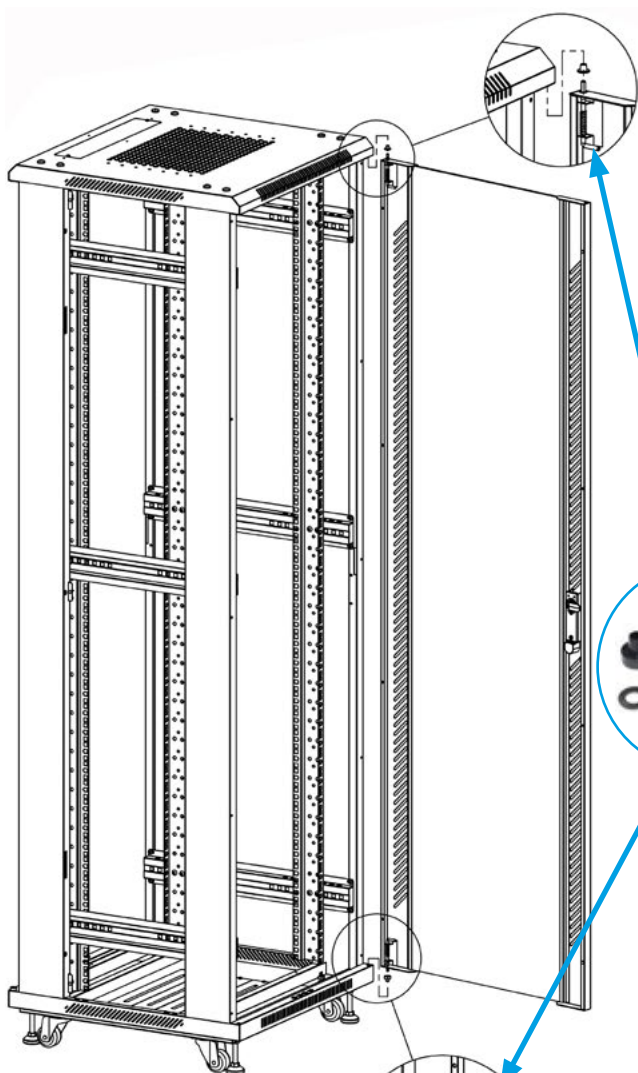
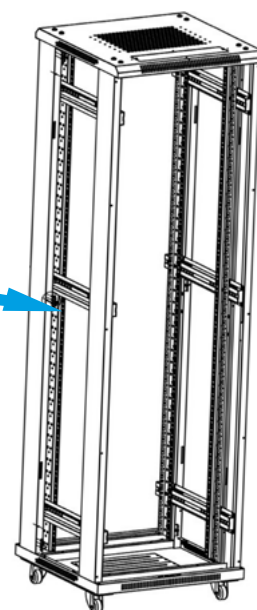
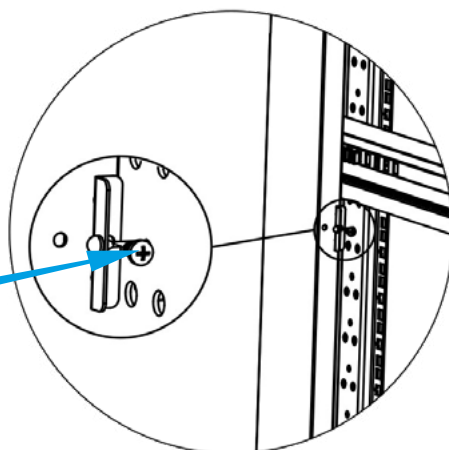

Pas 11. Pregătiți și poziționați distanțierele ușii (articol W) pentru ușa frontală și panoul spate (articolele A și B) în locurile corespunzătoare. Montați panourile laterale (articol C) la final.











1. Инструкции за монтаж

i Уверете се, че стриктно следвате инструкциите в това ръководство.



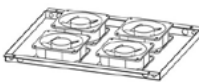

1.1 Подготовка

Подгответе подходящо количество свободно пространство на повърхността, върху която ще се извършва монтажът. Внимателно извадете всички елементи от транспортната кутия. Следващите инструкции за монтаж ще се базират на предоставената схема

1.1.1. Таблица с аксесоари

| Части на шкафа | | | | |
|----------------|--------------------------|---|---------------------------------|------------------------|
| № елемент | Наименование на елемента | Чертеж на елемента | Необходимо количество | Количество в комплекта |
| Елемент А | Предна стъклена врата |  | 1 бр. | 1 бр. |
| Елемент В | Заден панел |  | 1 бр. | 1 бр. |
| Елемент С | Странични панели |  | 2 бр. | 2 бр. |
| Елемент D | Рамка |  | 2 бр. | 2 бр. |
| Елемент E | Горен капак |  | 1 бр. | 1 бр. |
| Елемент F | Долен капак |  | 1 бр. | 1 бр. |
| Елемент G | Напречна греда |  | 15U~27U 4 бр. 32U~42U 6 бр. | |
| Елемент H | Рафт за вентилатори |  | 1 бр. | 1 бр. |
| Елемент I | Монтажни шини |  | 4 бр. | 4 бр. |
| Елемент J | Капачка на горния панел |  | Плосък 3 бр. Набразден 4 бр. | |

| | | | | |
|-----------|------------------------------|--|---------------------------------|-------|
| Елемент К | Регулируеми крачета |  | 4 бр. | 4 бр. |
| Елемент L | Колела със спирачка |  | 4 бр. | 4 бр. |
| Елемент M | Ограничители на вратата |  | 15U~27U 8 бр. 32U~42U 12 бр. | |
| Елемент N | Заклучалка на предната врата |  | 1 бр. | 1 бр. |
| Елемент O | Заклучалка на задния панел |  | 3 бр. | 3 бр. |
| Елемент W | Дистанционери за врата |  | 2 бр. | 4 бр. |

| Винтове | | | | |
|-----------|---------------------------------|---|-----------------------|------------------------|
| № елемент | Наименование на елемента | Чертеж на елемента | Необходимо количество | Количество в комплекта |
| Елемент Q | Винт с вътрешен шестограм М8 |  | 16 бр. | 17 бр. |
| Елемент R | Самонарезни винтове М5*10 |  | 15U~27U 36 бр. | 40 бр. |
| | | | 32U~42U 44 бр. | 50 бр. |
| Елемент S | Самонарезни винтове М4*8 |  | 15U~27U 20 бр. | 23 бр. |
| | | | 32U~42U 26 бр. | 30 бр. |
| Елемент Т | Клетъчна гайка М6 |  | 15U~27U 32 бр. | 35 бр. |
| | | | 32U~42U 48 бр. | 50 бр. |
| Елемент U | Винт с вътрешен шестограм М6х12 |  | 15U~27U 32 бр. | 35 бр. |
| | | | 32U~42U 48 бр. | 52 бр. |
| Елемент V | Допълнителен винт и гайка М6 |  | 20 бр. | 20 бр. |

2. Етапи на монтаж

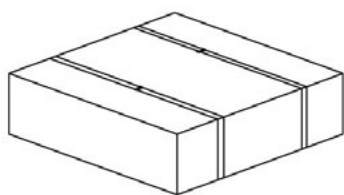

ГОРЕН И ДОЛЕН ПАКЕТ 1/3

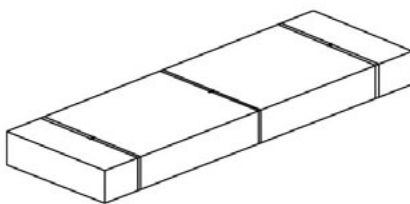

ПРЕДНА ВРАТА, ЗАДЕН ПАНЕЛ
И СТРАНИЧНИ ПАНЕЛИ 2/3

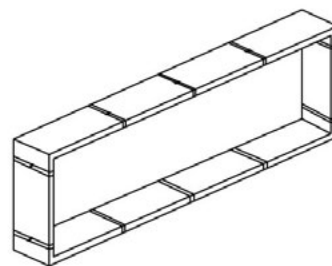

ПАКЕТ РАМКА 3/3

Стъпка 1. Свалете заключалката на предната врата (елемент N), заключалките на страничните панели и заключалката на задния панел (елемент O); компонентите са в пакет 1/3. След това извадете предната стъклена врата (елемент A), задния панел (елемент B) и страничните панели (елемент C) от пакет 2/3. На този етап започваме с монтирането на заключалки към горните компоненти.

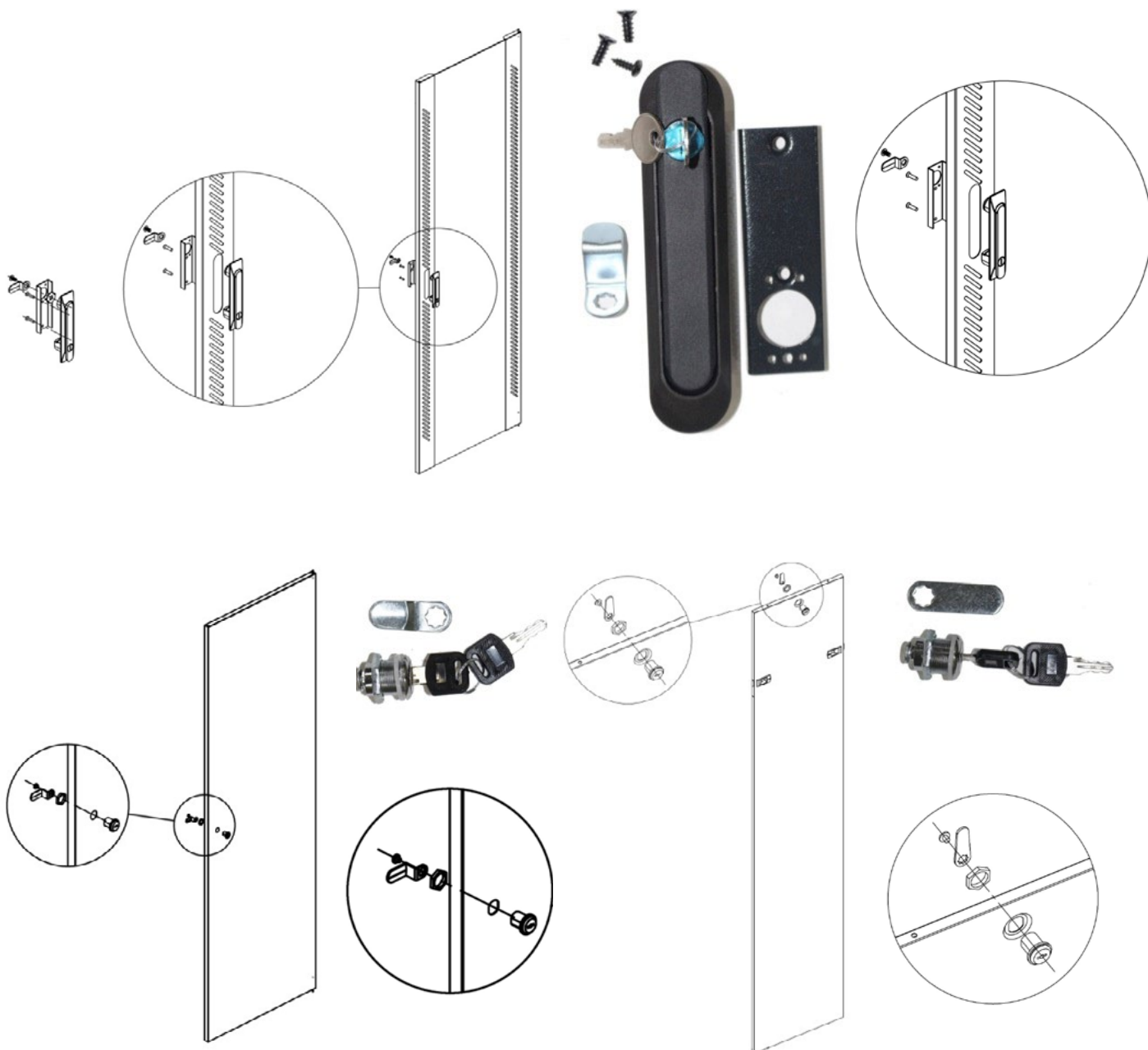

Стъпка 2. Разопакувайте частите на рамката (елемент J) от пакет 3/3. След това подредете рамките успоредно една на друга, като квадратните отвори са обърнати навътре. Долната част на рамката може да разпознаете по елемента за монтаж на заземяването.

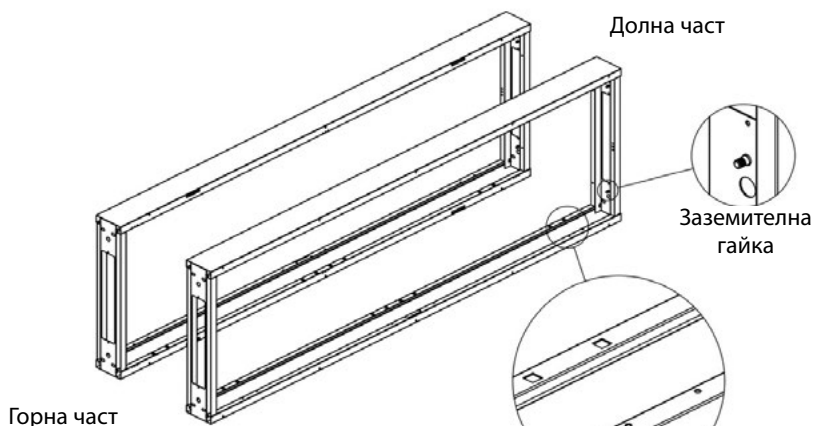

Стъпка 3. Монтирайте горния капак (елемент E) върху горната част на рамката (елемент D), след което използвайте винт с вътрешен шестограм M8 (елемент Q), за да ги сглобите заедно.

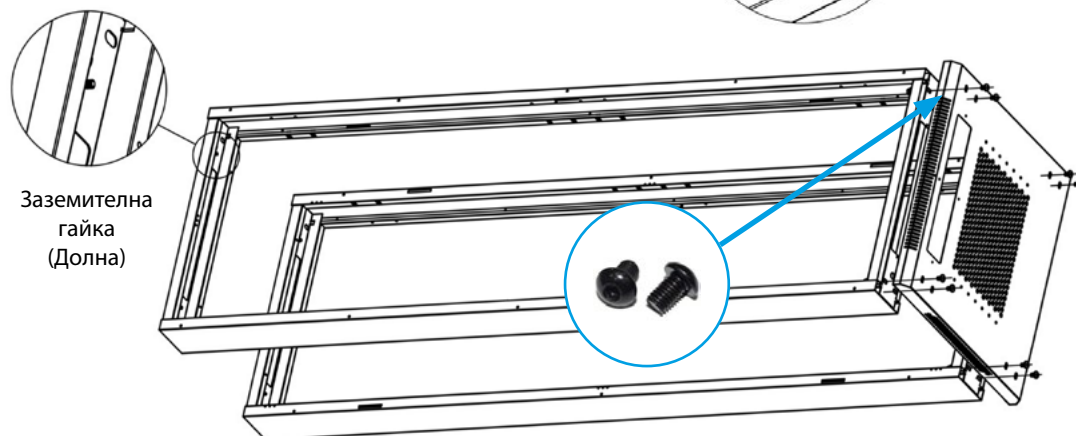

Стъпка 4. Монтирайте долния капак (елемент F) върху долната част на рамката (елемент D) и след това използвайте болт с вътрешен шестограм M8 (елемент Q), за да ги съедините.

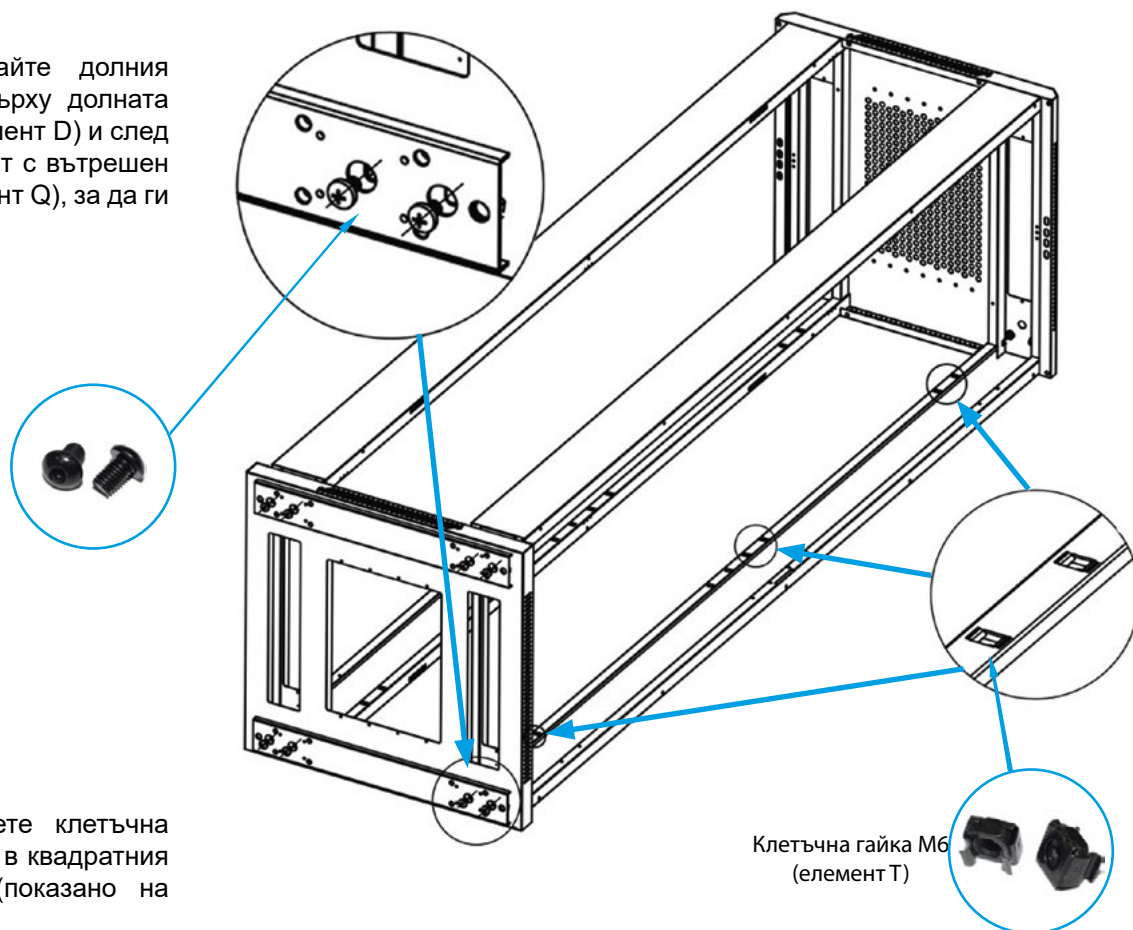

Стъпка 4а. Поставете клетъчна гайка M6 (елемент T) в квадратния отвор на рамката (показано на фигурата).

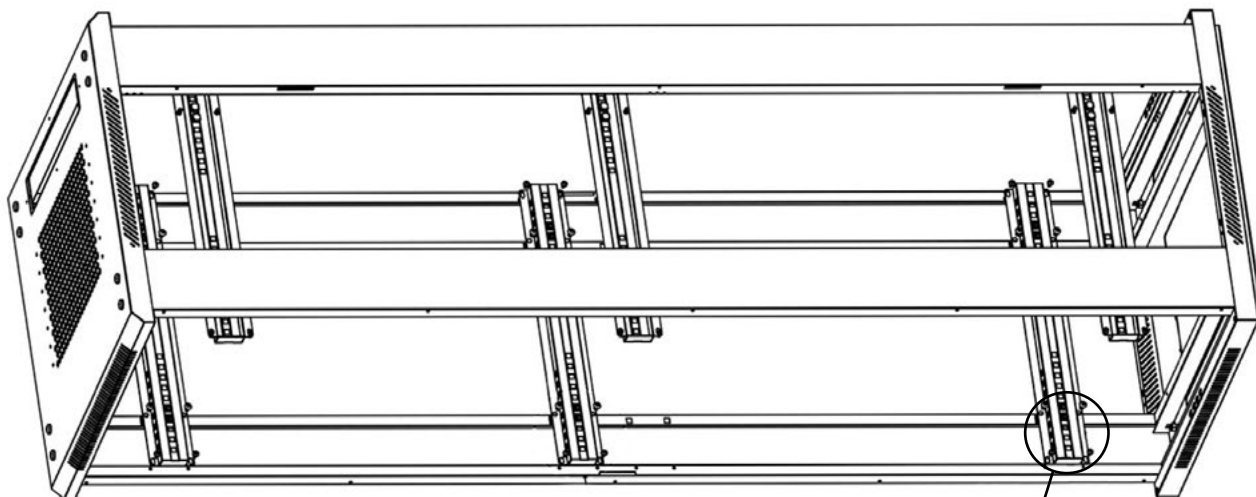

Стъпка 5. Подгответе клетъчни гайки M6 (елемент T) и ги закрепете към напречната греда (елемент G), след което поставете напречната греда върху рамката (елемент D), като избягвате отвора за заключване в рамката. Използвайте винт с вътрешен шестограм M6 (елемент U) и самонарезен винт M5 (елемент R), за да фиксирате напречната греда.



Болт с вътрешен шестограм M6 (елемент U)



Самонарезен винт M5 (елемент R)

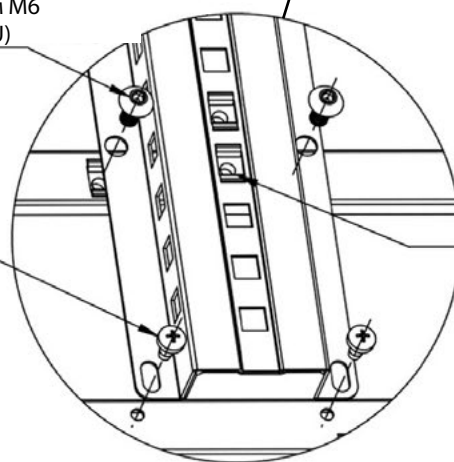

Клетъчна гайка M6 (елемент T)

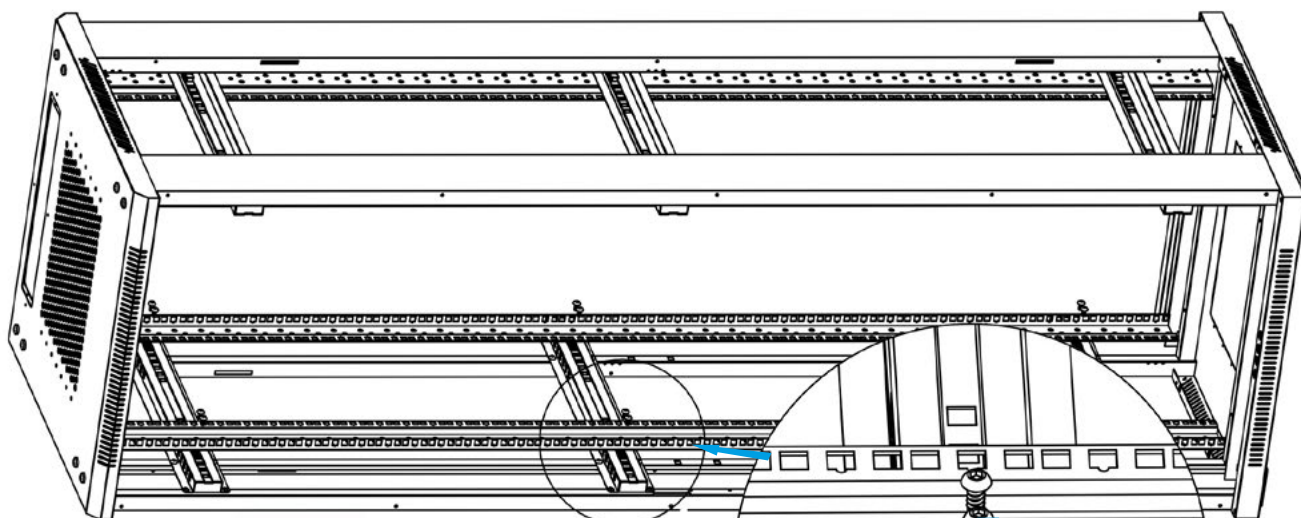

Стъпка 6. Подгответе монтажните винтове M6 (елемент U). Използвайте винтовете, за да закрепите вертикалните монтажни шини (елемент I) към хоризонталните напречни греди (елемент G).



Болт с вътрешен шестограм M6 (елемент U)

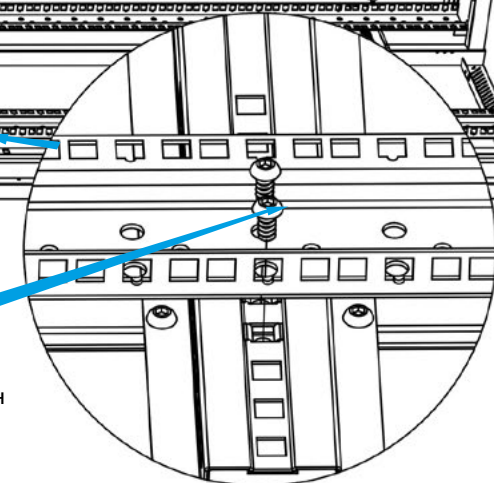

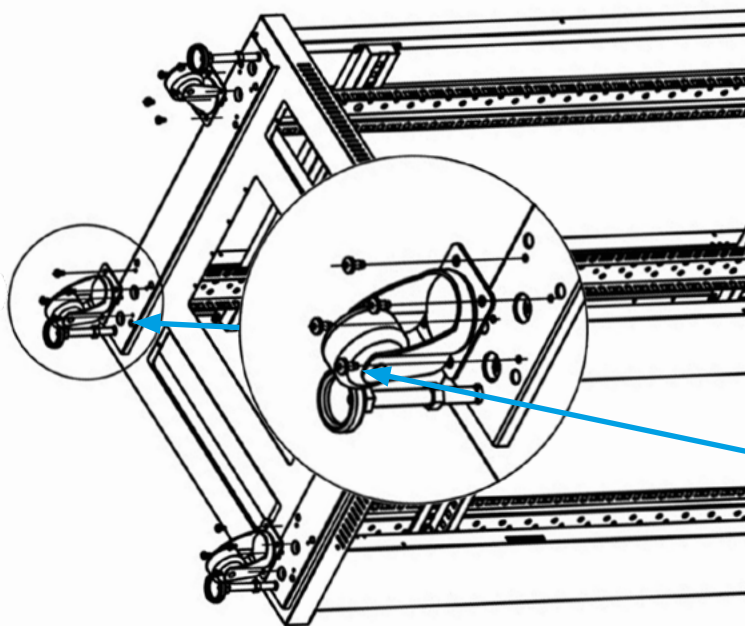

Стъпка 7. Подгответе самонарезните винтове M5 (елемент R), за да закрепите четирите колела със спирачка (елемент L) към долния капак (елемент F). След това монтирайте регулируемите крачета (елемент K) към долния капак.



Самонарезен винт M5 (елемент R)

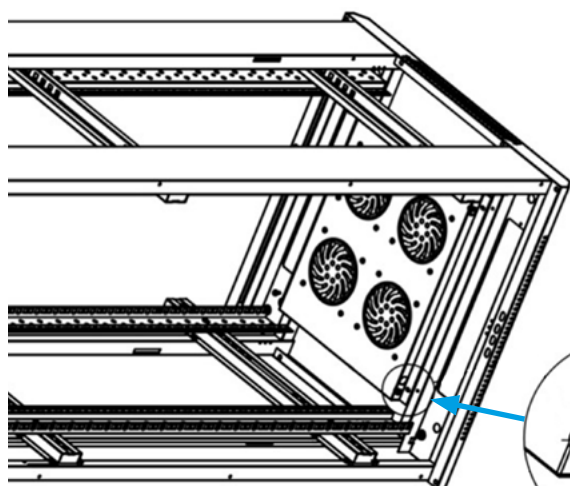

Стъпка 8. Подгответе самонарезните винтове M5 (елемент R), след което ги използвайте, за да закрепите рафта за вентилатори (елемент H) към рамката RACK (елемент D).



Самонарезен винт M5 (елемент R)

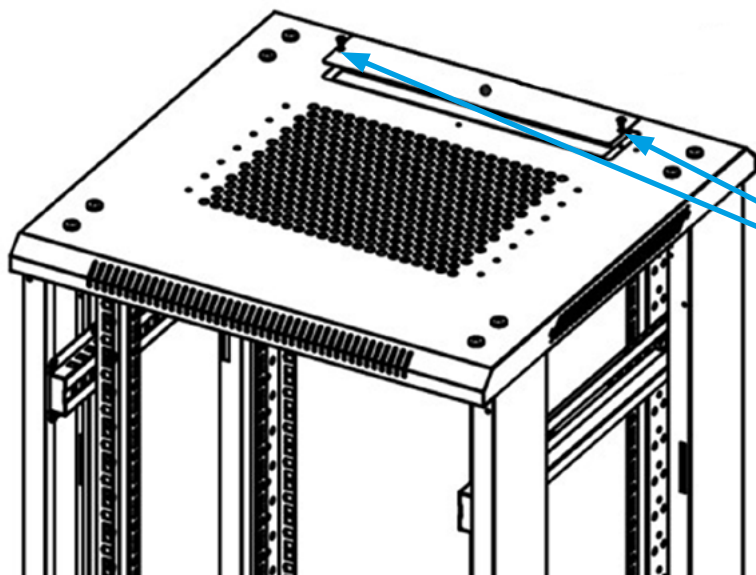

Стъпка 9. Подгответе и използвайте самонарезен винт M4 (елемент S), за да закрепите капачката на горния панел (елемент J).



Самонарезен винт M4 (елемент S)

Стъпка 10. Подгответе и използвайте самонарезни винтове M4 (елемент S), за да закрепите ограничителите на вратата (елемент M). За размери 15U~27U (8 бр.), 32U~47U (12 бр.).



Самонарезен винт M4
(елемент S)

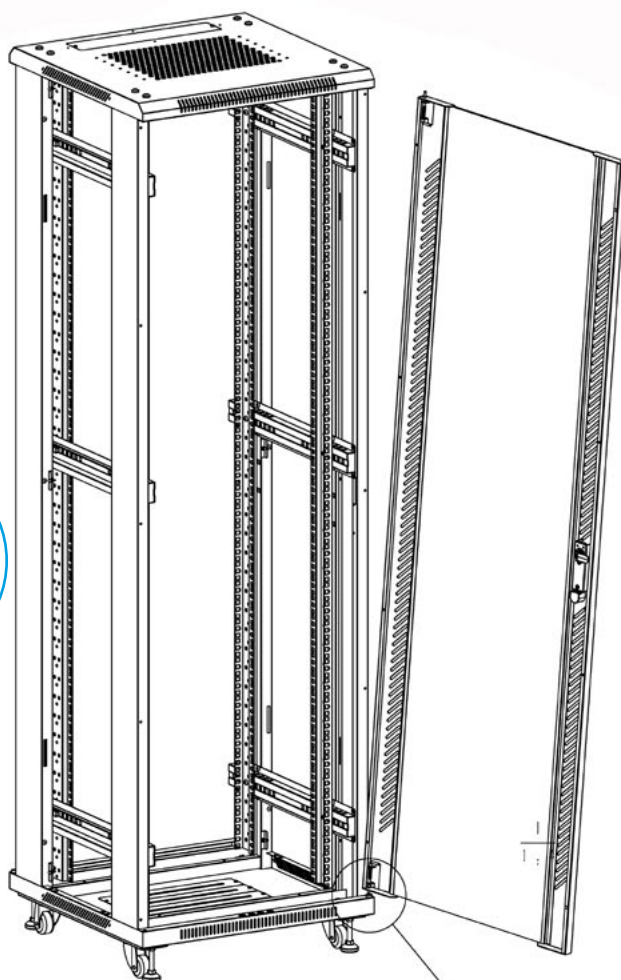
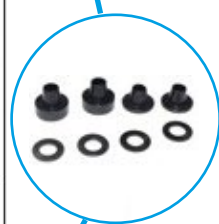
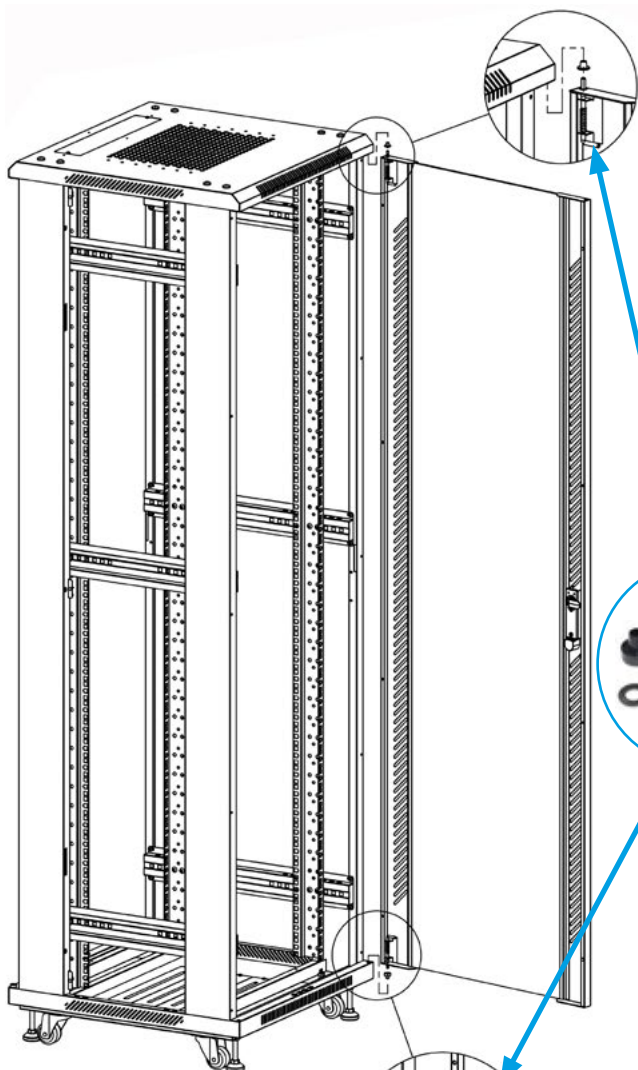
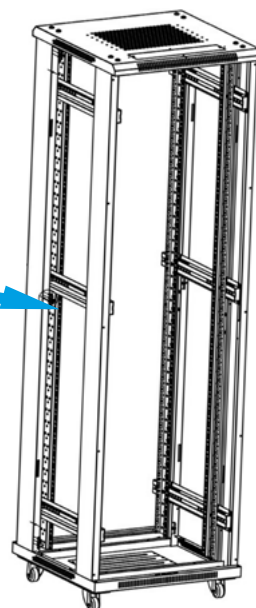
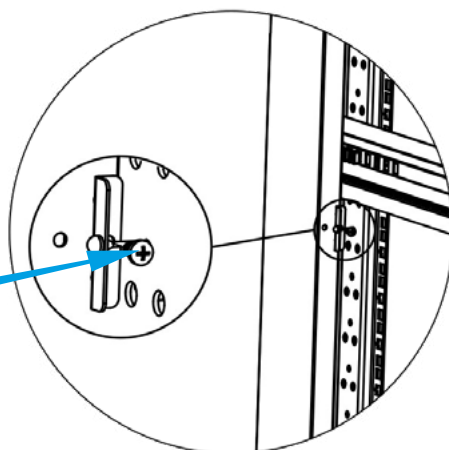

Стъпка 11. Подгответе и поставете дистанционерите за врата (елемент W) за предната врата и задния панел (елементи A и B) на съответните места. Монтирайте страничните панели (елемент C) накрая.

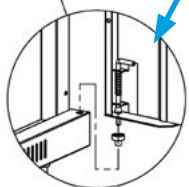









1. Összeszerelési útmutató





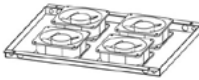

i **Ügyeljen arra, hogy szigorúan kövesse a kézikönyv utasításait.**







1.1 Előkészületek

Készítsen elő megfelelő mennyiségű szabad helyet azon a felületen, ahol az összeszerelés történik. Óvatosan távolítsa el az összes elemet a szállítódobozból. A további összeszerelési utasítások a mellékelt ábra alapján készülnek

1.1.1. Tartozék táblázat

| Szekrény alkatrészei | | | | |
|----------------------|-------------------|---|------------------------------|------------------------|
| Tételszám | Megnevezés | Tételrajz | Szükséges mennyiség | Mennyiség a készletben |
| Elem A | Elülső üvegajtó |  | 1 db | 1 db |
| Elem B | Hátlap |  | 1 db | 1 db |
| Elem C | Oldalpanelek |  | 2 db | 2 db |
| Elem D | Keret |  | 2 db | 2 db |
| Elem E | Felső burkolat |  | 1 db | 1 db |
| Elem F | Alsó burkolat |  | 1 db | 1 db |
| Elem G | Kereszttartó |  | 15U~27U 4 db 32U~42U 6 db | |
| Elem H | Ventilátorpolc |  | 1 db | 1 db |
| Elem I | Szerelősínek |  | 4 db | 4 db |
| Elem J | Felső panel kupak |  | Lapos 3 db Hornlyolt 4 db | |

| | | | | |
|--------|-------------------|--|-------------------------------|------|
| Elem K | Állítható lábak |  | 4 db | 4 db |
| Elem L | Fékezhető kerekek |  | 4 db | 4 db |
| Elem M | Ajtóütközők |  | 15U~27U 8 db 32U~42U 12 db | |
| Elem N | Elülső ajtózárr |  | 1 db | 1 db |
| Elem O | Hátsó panelzár |  | 3 db | 3 db |
| Elem W | Ajtótávtartók |  | 2 db | 4 db |

| Csavarok | | | | |
|-----------|------------------------------|---|---------------------|------------------------|
| Tételszám | Megnevezés | Tételrajz | Szükséges mennyiség | Mennyiség a készletben |
| Elem Q | M8 imbuszcsavar |  | 16 db | 17 db |
| Elem R | M5*10 önmetsző csavarok |  | 15U~27U 36 db | 40 db |
| | | | 32U~42U 44 db | 50 db |
| Elem S | M4*8 önmetsző csavarok |  | 15U~27U 20 db | 23 db |
| | | | 32U~42U 26 db | 30 db |
| Elem T | M6 ketrecanya |  | 15U~27U 32 db | 35 db |
| | | | 32U~42U 48 db | 50 db |
| Elem U | M6x12 imbuszcsavar |  | 15U~27U 32 db | 35 db |
| | | | 32U~42U 48 db | 52 db |
| Elem V | M6 kiegészítő csavar és anya |  | 20 db | 20 db |

2. Összeszerelési lépések

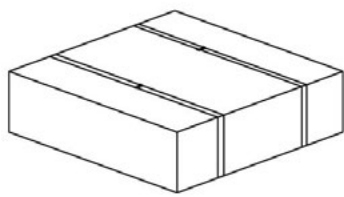

FELSŐ ÉS ALSÓ CSOMAG 1/3

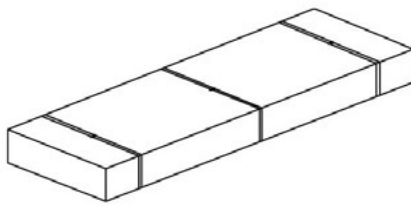

ELÜLSŐ AJTÓ, HÁT LAP ÉS
OLDALPANELEK 2/3

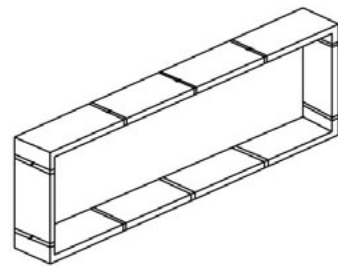

KERET CSOMAG 3/3

1. lépés Távolítsa el az elülső ajtózárat (elem N), az oldalpanelek zárjait és a hátsó panelzárat (elem O); az alkatrészek az 1/3 csomagban találhatóak. Ezután vegye ki az elülső üvegajtót (elem A), a hátlapot (elem B) és az oldalpaneleket (elem C) a 2/3 csomagból. Ebben a szakaszban megkezdjük a zárok felszerelését a fenti elemekre.



2. lépés. Csomagolja ki a keret elemeit (elem J) a 3/3 csomagból. Ezután rendezze a kereteket egymással párhuzamosan, úgy, hogy a négyzetes nyílások befelé nézzenek. A keret alsó része a földelés felszerelésére szolgáló elemről ismerhető fel.

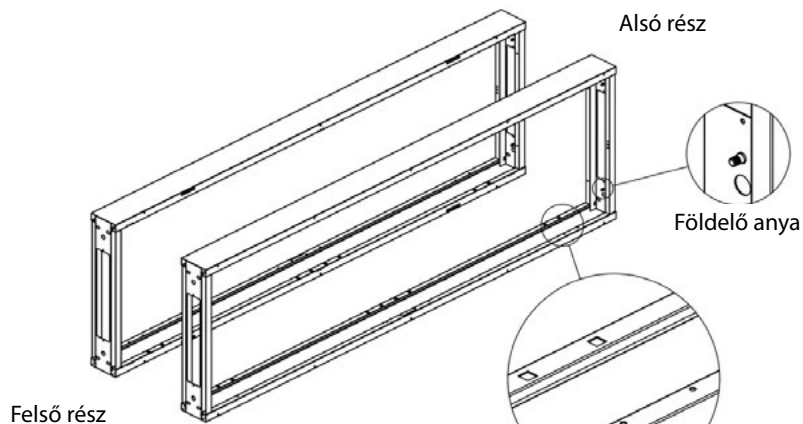

Lépés 3. Illessze a felső burkolatot (elem E) a keret felső részére (elem D), majd használjon egy M8 imbuszcavart (elem Q) az összeszereléshez együtt.

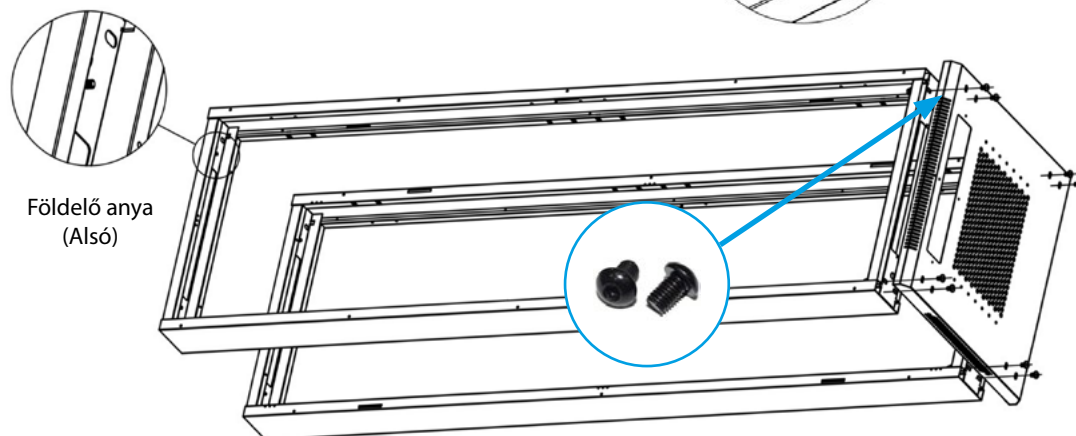

Lépés 4. Illessze az alsó burkolatot (elem F) a keret alsó részére (elem D), majd használjon egy M8 imbuszcavart (elem Q) az összekapcsoláshoz.

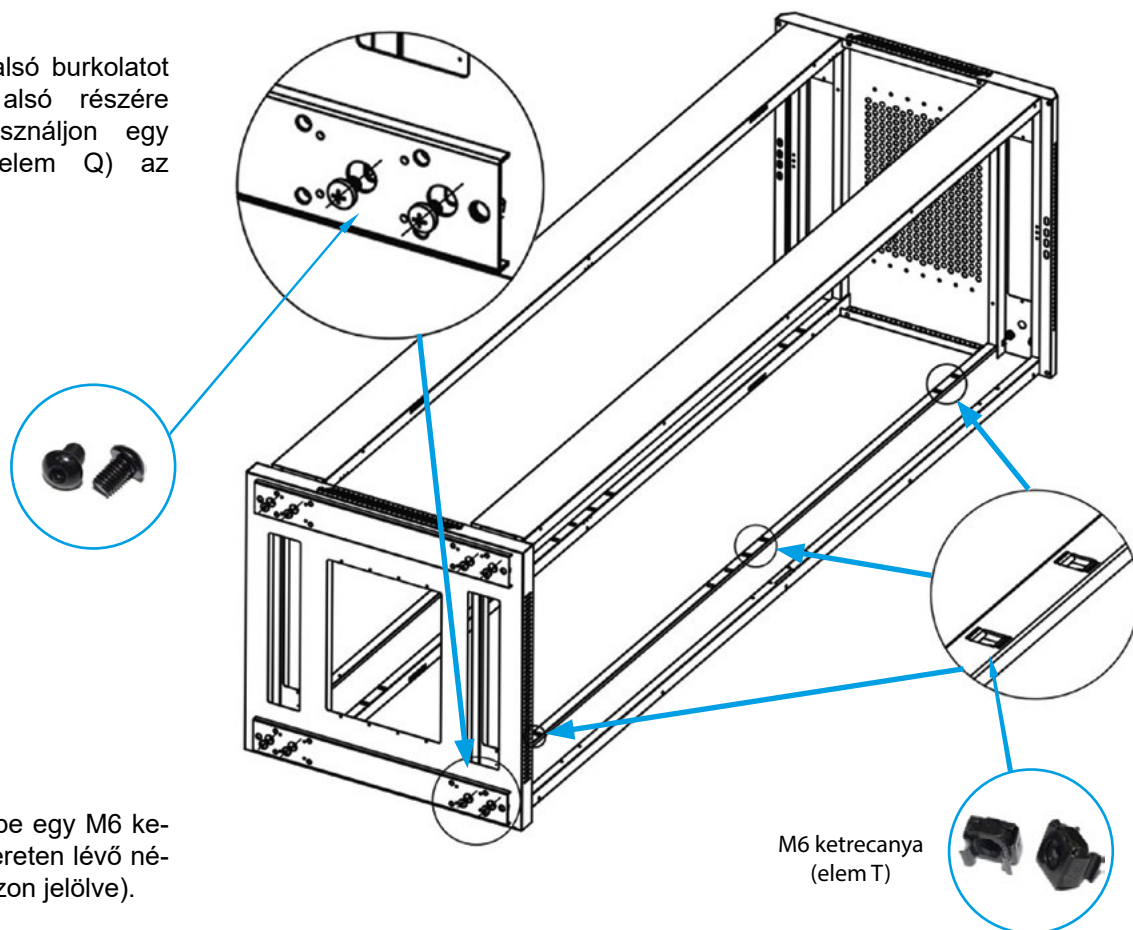

Lépés 4a. Helyezzen be egy M6 ketrecanyát (elem T) a kereten lévő négyzetes nyílásba (a rajzon jelölve).

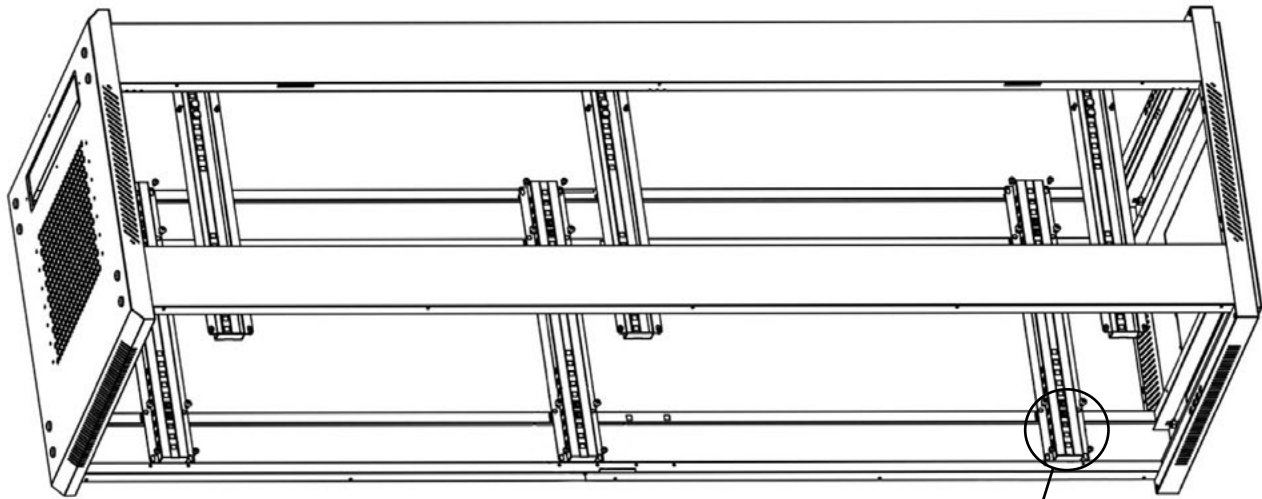

M6 imbuszcavar
(elem U)

Lépés 5. Készítse elő az M6 ketrecanyákat (elem T) és rögzítse őket a kereszttartóra (elem G), majd helyezze a kereszttartót a keretre (elem D), elkerülve a kereten lévő zárónyílást. A kereszttartó rögzítéséhez használjon egy M6 imbuszcavart (elem U) és egy M5 önmetsző csavart (elem R).

M5 önmetsző csavar
(elem R)

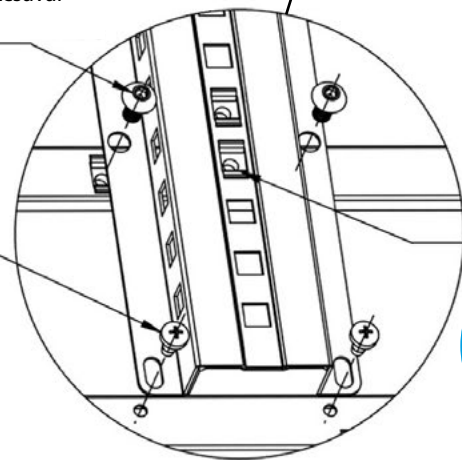

M6 ketrecanya
(elem T)

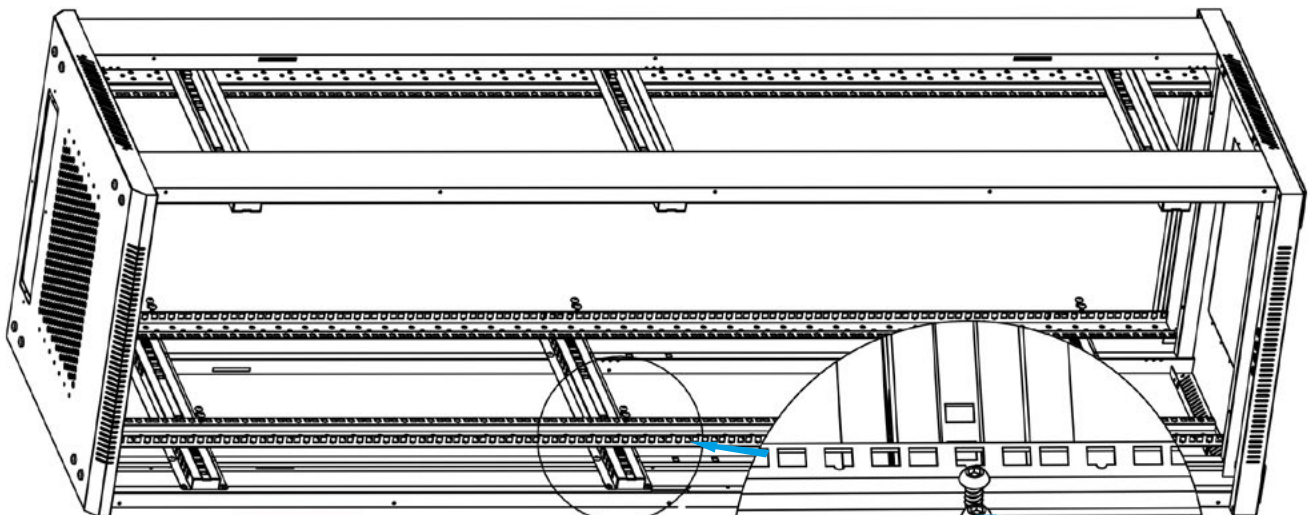

Lépés 6. Készítse elő az M6 rögzítőcsavarokat (elem U). A csavarokkal rögzítse a függőleges szerelősíneket (elem I) a vízszintes kereszttartókhoz (elem G).



M6 imbuszcavar
(elem U)

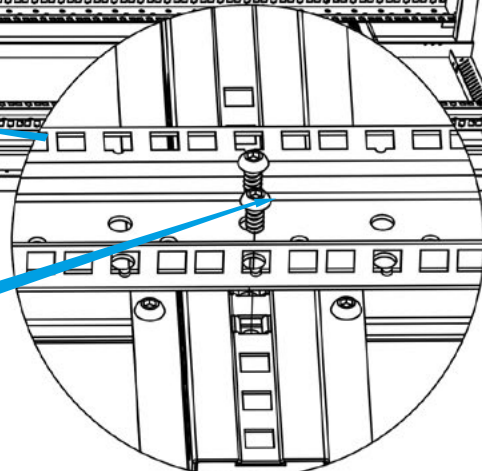

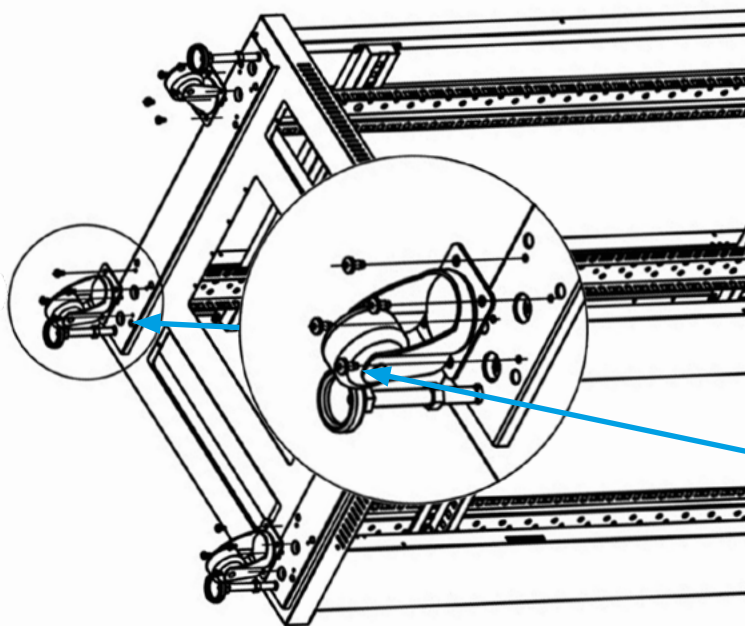

Lépés 7. Készítse elő az M5 önmetsző csavarokat (elem R), hogy rögzítse a négy fékezhető kereket (elem L) az alsó burkolathoz (elem F). Ezután szerelje fel az állítható lábakat (elem K) az alsó burkolatra.



M5 önmetsző csavar (elem R)

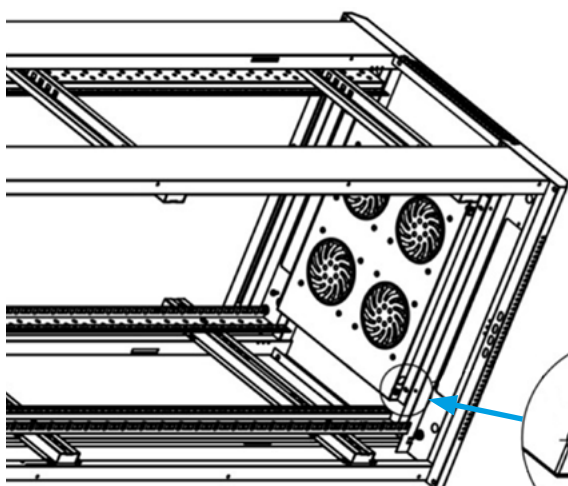

Lépés 8. Készítse elő az M5 önmetsző csavarokat (elem R), majd ezekkel rögzítse a ventilátorpolcot (elem H) a RACK kerethez (elem D).



M5 önmetsző csavar (elem R)

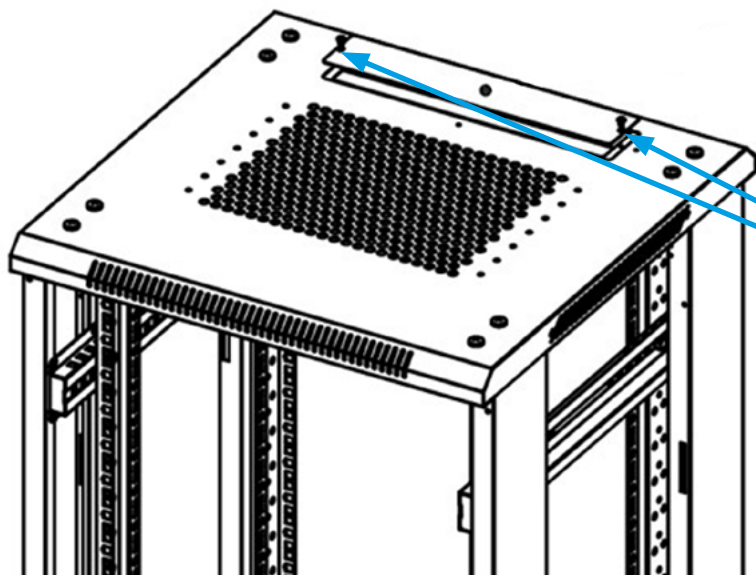

Lépés 9. Készítse elő és használjon egy M4 önmetsző csavart (elem S) a felső panel kupakjának (elem J) rögzítéséhez.



M4 önmetsző csavar (elem S)

Lépés 10. Készítse elő és használja az M4 önmetsző csavarokat (elem S) az ajtóútközök (elem M) rögzítéséhez. Méretekhez: 15U~27U (8 db), 32U~47U (12 db).



M4 önmetsző csavar
(elem S)

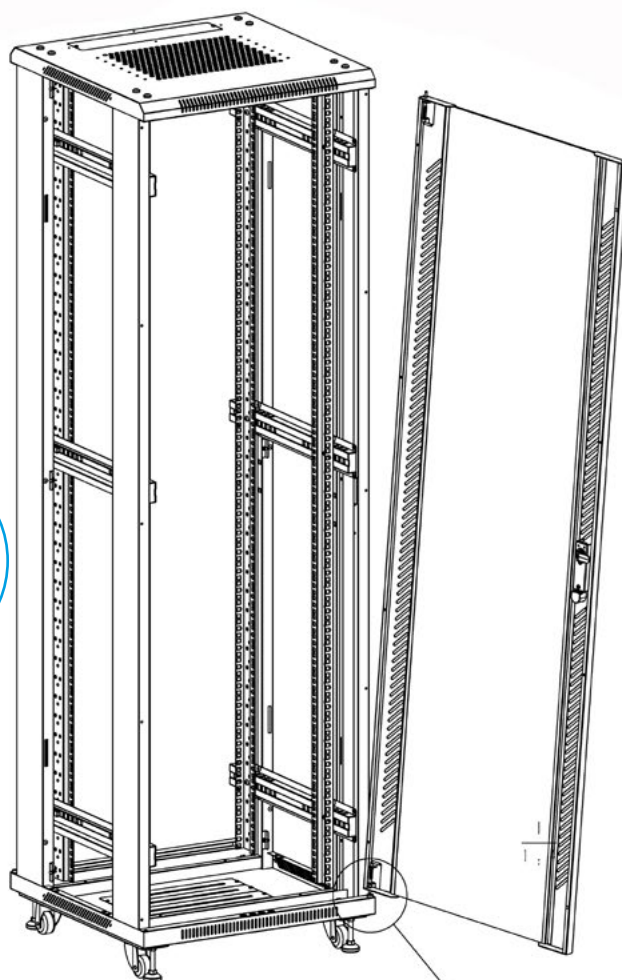
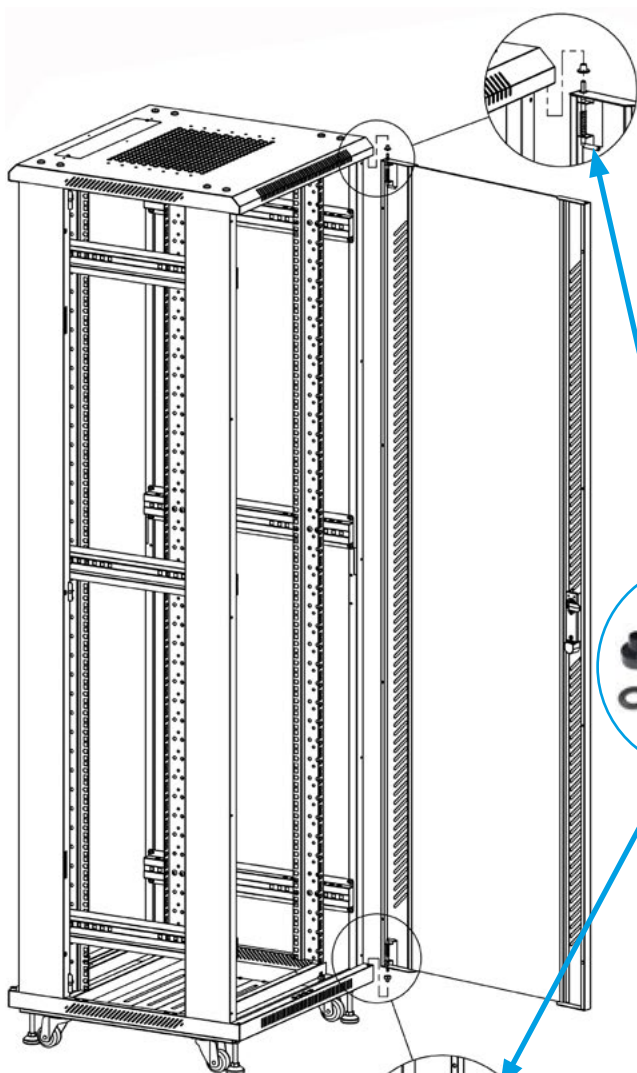
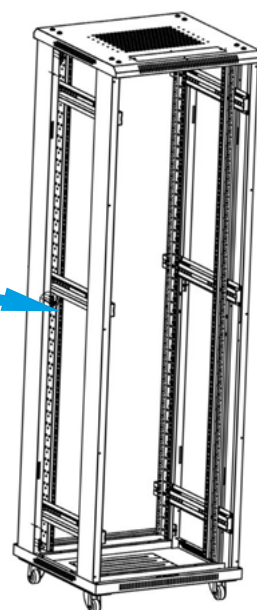
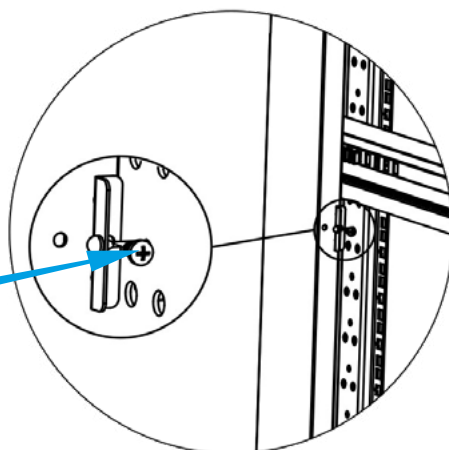

Lépés 11. Készítse elő és helyezze fel az ajtóútközöket (elem W) az előlaphoz és a hátlaphoz (elemek A és B) a megfelelő helyekre. Az oldalpaneleket (elem C) csak a legvégén szerelje fel.











1. Uputstvo za montažu





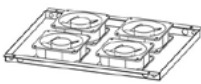

i **Obavezno strogo pratite uputstva iz ovog priručnika.**

1.1 Priprema

Pripremite odgovarajuću količinu slobodnog prostora na površini na kojoj će se vršiti montaža. Pažljivo izvadite sve elemente iz transportne kutije. Dalja uputstva za montažu biće zasnovana na priloženom dijagramu

1.1.1. Tabela dodataka

| Delovi ormara | | | | |
|---------------|------------------------|---|-----------------------------------|-----------------|
| Br. stavke | Naziv stavke | Crtež stavke | Potrebna količina | Broj u kompletu |
| Stavka A | Prednja staklena vrata |  | 1 kom. | 1 kom. |
| Stavka B | Zadnji panel |  | 1 kom. | 1 kom. |
| Stavka C | Bočni paneli |  | 2 kom. | 2 kom. |
| Stavka D | Ram |  | 2 kom. | 2 kom. |
| Stavka E | Gornji poklopac |  | 1 kom. | 1 kom. |
| Stavka F | Donji poklopac |  | 1 kom. | 1 kom. |
| Stavka G | Poprečna prečka |  | 15U~27U 4 kom. 32U~42U 6 kom. | |
| Stavka H | Polica za ventilatore |  | 1 kom. | 1 kom. |
| Stavka I | Montažne šine |  | 4 kom. | 4 kom. |
| Stavka J | Kapica gornjeg panela |  | Ravno 3 kom. Žljebljeno 4 kom. | |

| | | | | |
|----------|----------------------|--|-----------------------------------|--------|
| Stavka K | Podesive nogice |  | 4 kom. | 4 kom. |
| Stavka L | Točkovi sa kočnicama |  | 4 kom. | 4 kom. |
| Stavka M | Graničnici vrata |  | 15U~27U 8 kom. 32U~42U 12 kom. | |
| Stavka N | Brava prednjih vrata |  | 1 kom. | 1 kom. |
| Stavka O | Brava zadnjeg panela |  | 3 kom. | 3 kom. |
| Stavka W | Distanceri vrata |  | 2 kom. | 4 kom. |

| Vijci | | | | |
|------------|---------------------------|---|-------------------|-----------------|
| Br. stavke | Naziv stavke | Crtež stavke | Potrebna količina | Broj u kompletu |
| Stavka Q | M8 imbus vijak |  | 16 kom. | 17 kom. |
| Stavka R | Samorezni vijci M5*10 |  | 15U~27U 36 kom. | 40 kom. |
| | | | 32U~42U 44 kom. | 50 kom. |
| Stavka S | Samorezni vijci M4*8 |  | 15U~27U 20 kom. | 23 kom. |
| | | | 32U~42U 26 kom. | 30 kom. |
| Stavka T | M6 kavezna matica |  | 15U~27U 32 kom. | 35 kom. |
| | | | 32U~42U 48 kom. | 50 kom. |
| Stavka U | M6x12 imbus vijak |  | 15U~27U 32 kom. | 35 kom. |
| | | | 32U~42U 48 kom. | 52 kom. |
| Stavka V | Dodatni vijak i matica M6 |  | 20 kom. | 20 kom. |

2. Faze montaže

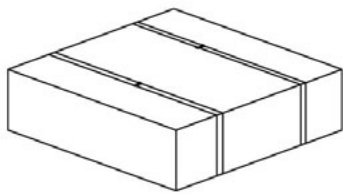

GORNJI I DONJI PAKET 1/3

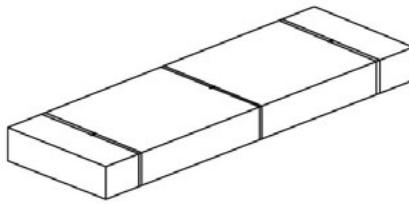

PREDNJA VRATA, ZADNJI
PANEL I BOČNI PANELI 2/3

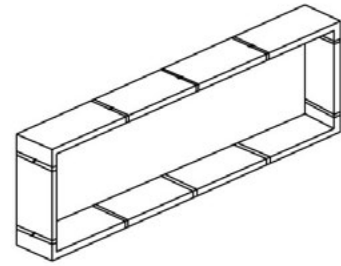

PAKET RAMA 3/3

Korak 1. Uklonite bravu prednjih vrata (stavka N), brave bočnih panela i bravu zadnjeg panela (stavka O); komponente su u paketu 1/3. Zatim izvadite prednja staklena vrata (stavka A), zadnji panel (stavka B) i bočne panele (stavka C) iz paketa 2/3. U ovoj fazi počinjemo sa ugradnjom brava na navedene komponente.



Korak 2. Raspakujte delove rama (stavka J) iz paketa 3/3. Zatim rasporedite ramove paralelno jedan pored drugog, tako da kvadratne rupe budu okrenute ka unutra. Donji deo rama možete prepoznati po elementu za ugradnju uzemljenja.

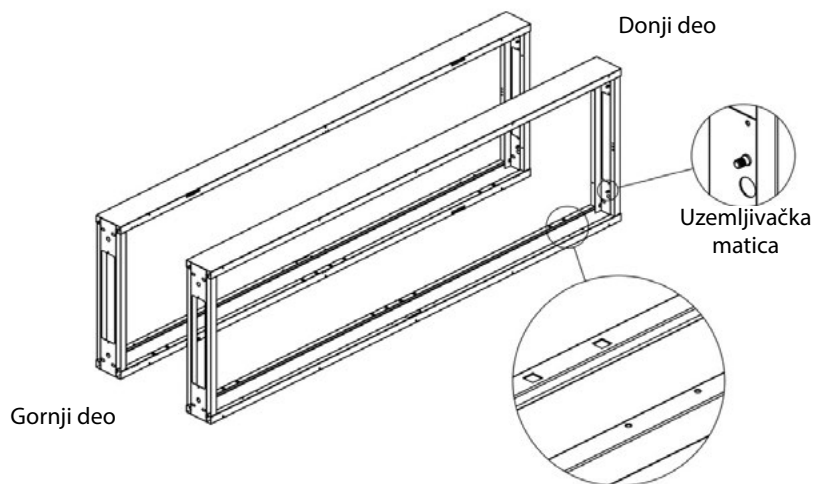

Korak 3. Postavite gornji poklopac (stavka E) na gornji deo rama (stavka D), zatim upotrebite M8 imbus vijak (stavka Q) da ih sastavite zajedno.

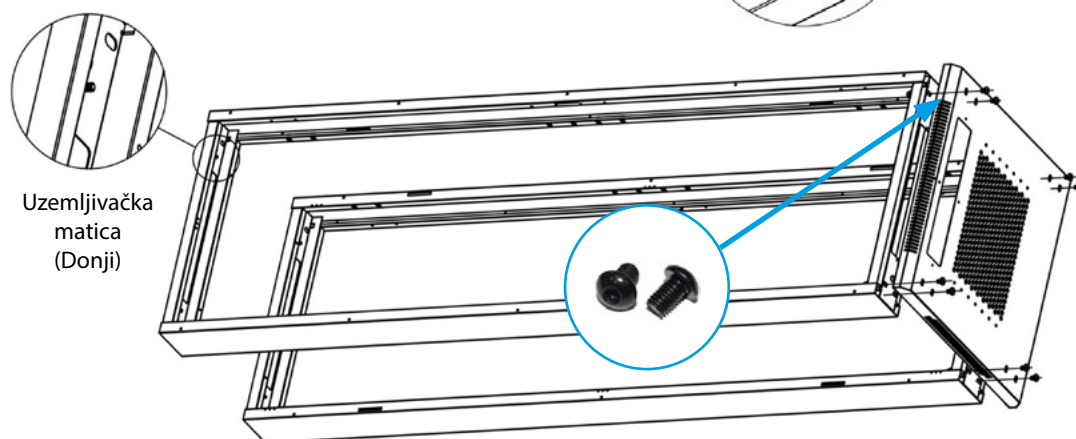

Korak 4. Postavite donji poklopac (stavka F) na donji deo rama (stavka D), zatim upotrebite M8 imbus vijak (stavka Q) da ih spojite.

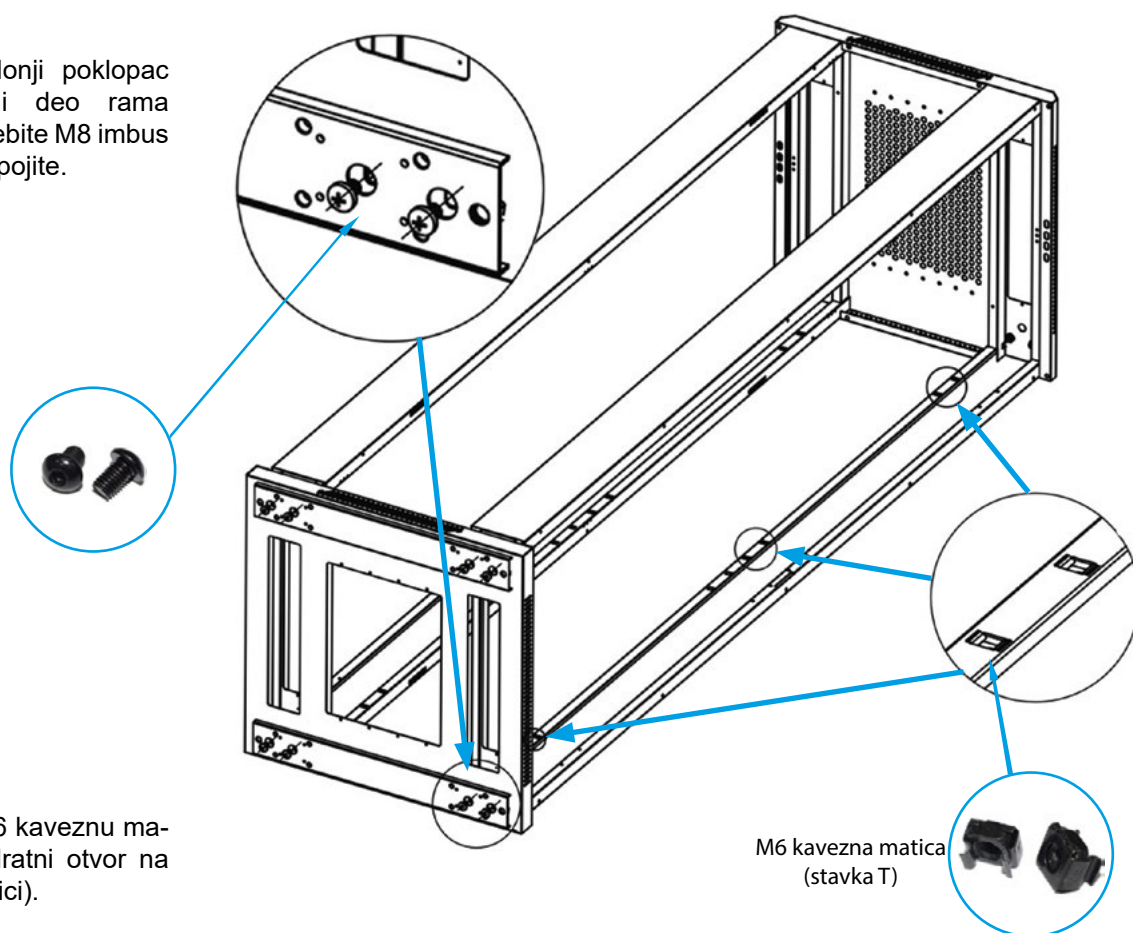

Korak 4a. Umetnite M6 kaveznu maticu (stavka T) u kvadratni otvor na ramu (naznačeno na slici).

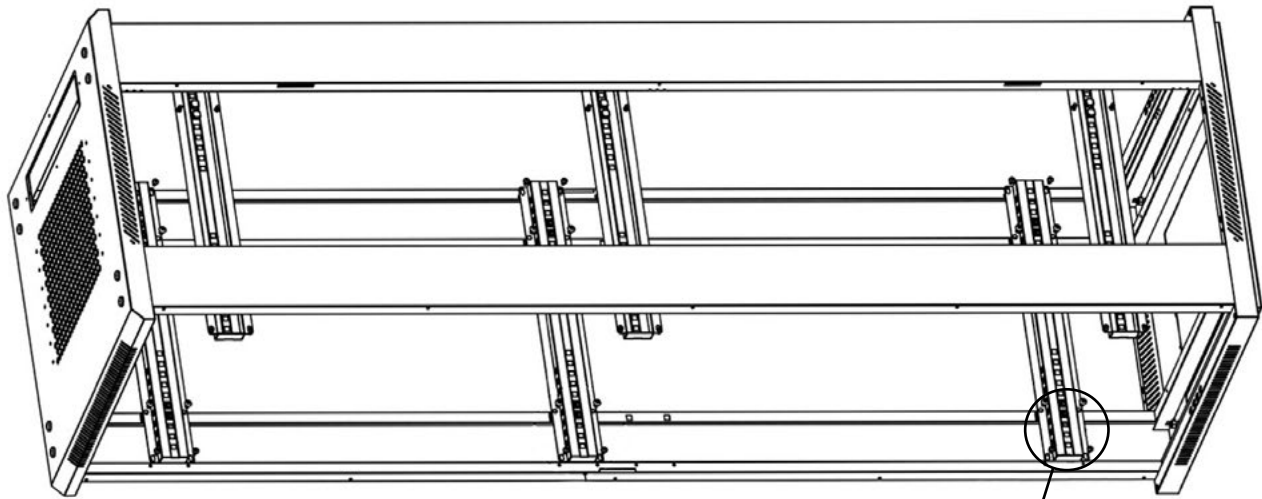

Imbus vijak M6
(stavka U)

Korak 5. Pripravite M6 kavezne matice (stavka T) i pričvrstite ih na poprečnu prečku (stavka G), zatim postavite prečku na ram (stavka D) izbegavajući otvor za zaključavanje na ramu. Koristite M6 imbus vijak (stavka U) i M5 samorezni vijak (stavka R) da pričvrstite prečku.

M5 samorezni vijak
(stavka R)

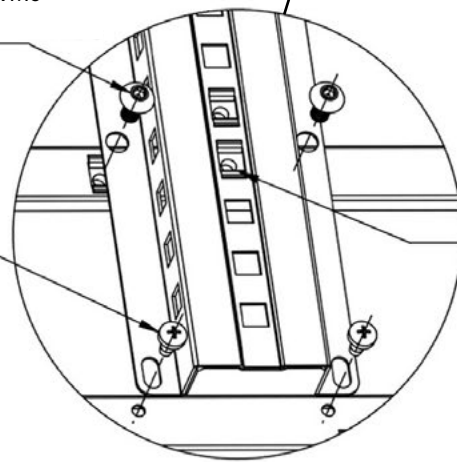

M6 kavezna matica (stavka T)

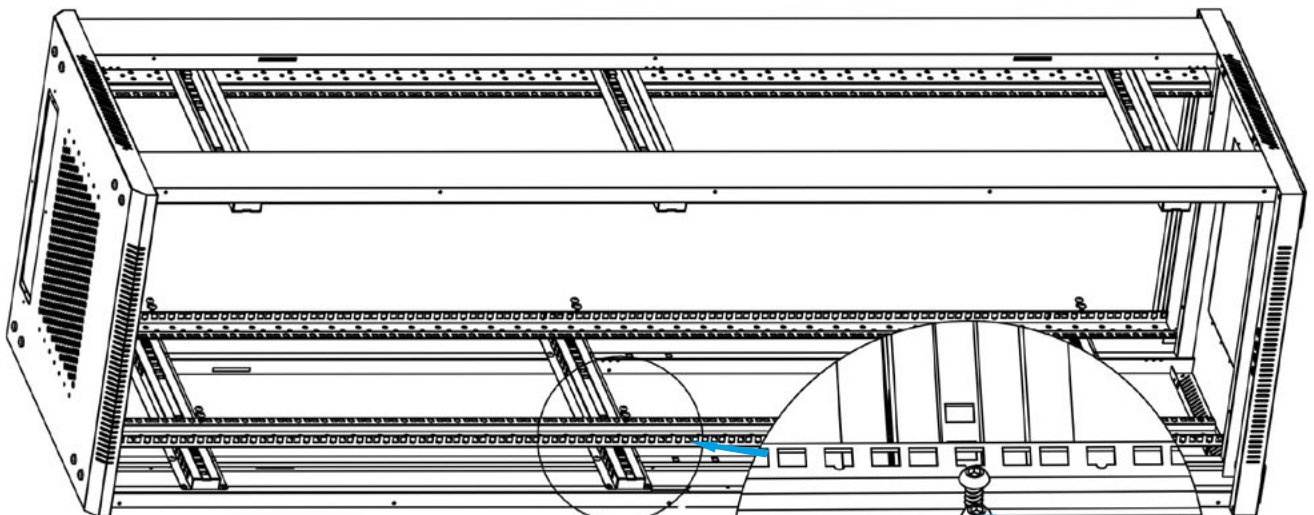

Korak 6. Pripravite M6 montažne vijke (stavka U). Koristite vijke da pričvrstite vertikalne montažne šine (stavka I) na horizontalne poprečne prečke (stavka G).



Imbus vijak M6
(stavka U)

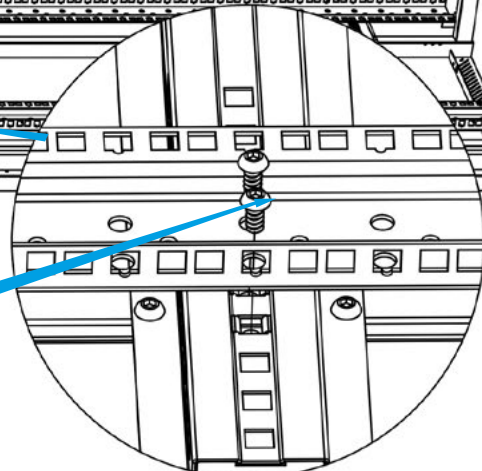

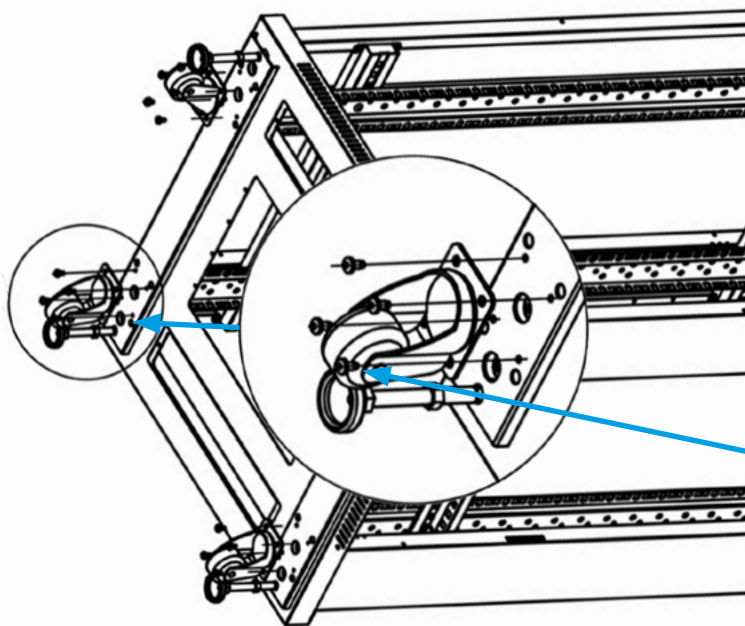

Korak 7. Pripravite M5 samorezne vijke (stavka R) da biste pričvrstili četiri točka sa kočnicama (stavka L) na donji poklopac (stavka F). Zatim montirajte podesive nogice (stavka K) na donji poklopac.



M5 samorezni vijak (stavka R)

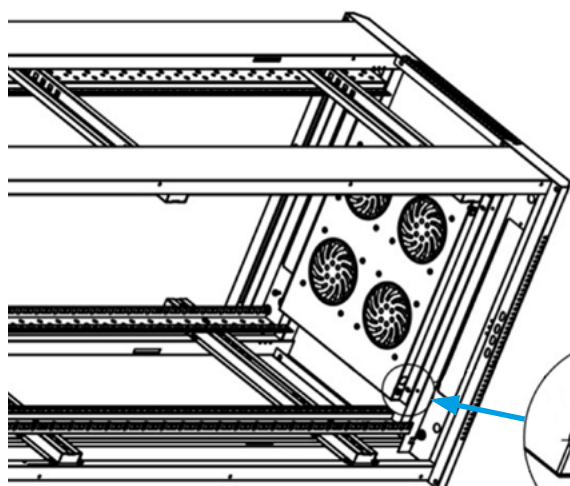

Korak 8. Pripravite M5 samorezne vijke (stavka R), zatim ih koristite da pričvrstite полицу за ventilatore (stavka H) на RACK ram (stavka D).



M5 samorezni vijak (stavka R)

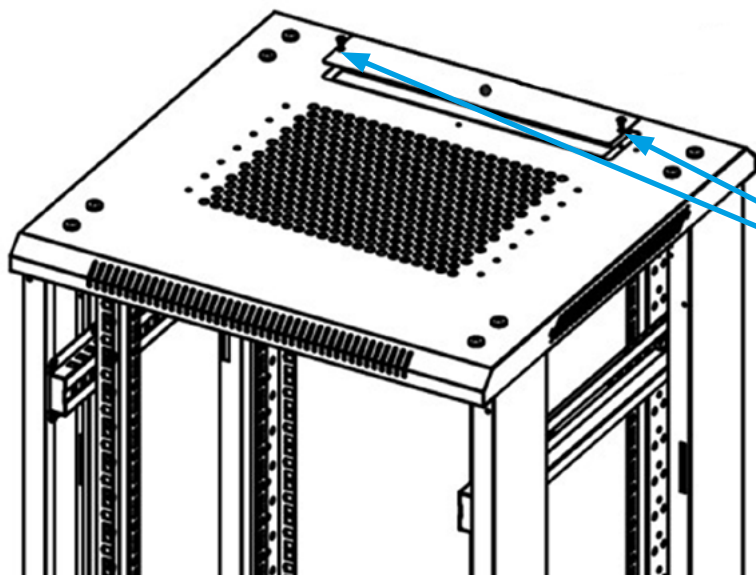

Korak 9. Pripravite i upotrebite M4 samorezni vijak (stavka S) da pričvrstite kapicu gornjeg panela (stavka J).



M4 samorezni vijak (stavka S)

Korak 10. Pripravite i koristite M4 samorezne vijke (stavka S) za pričvršćivanje graničnika vrata (stavka M). Za veličine 15U~27U (8 kom.), 32U~47U (12 kom.).



M4 samorezni vijak
(stavka S)

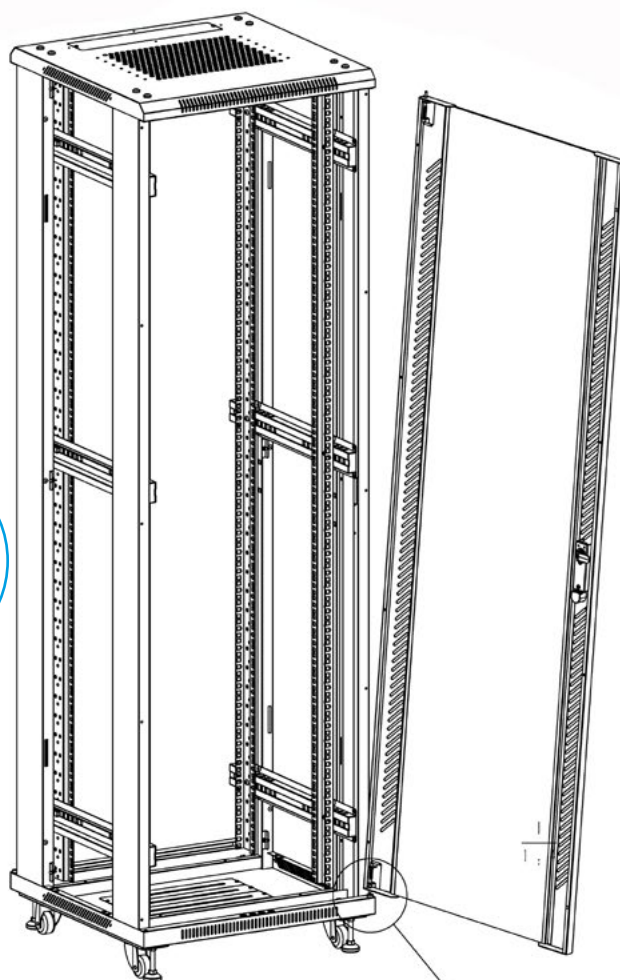
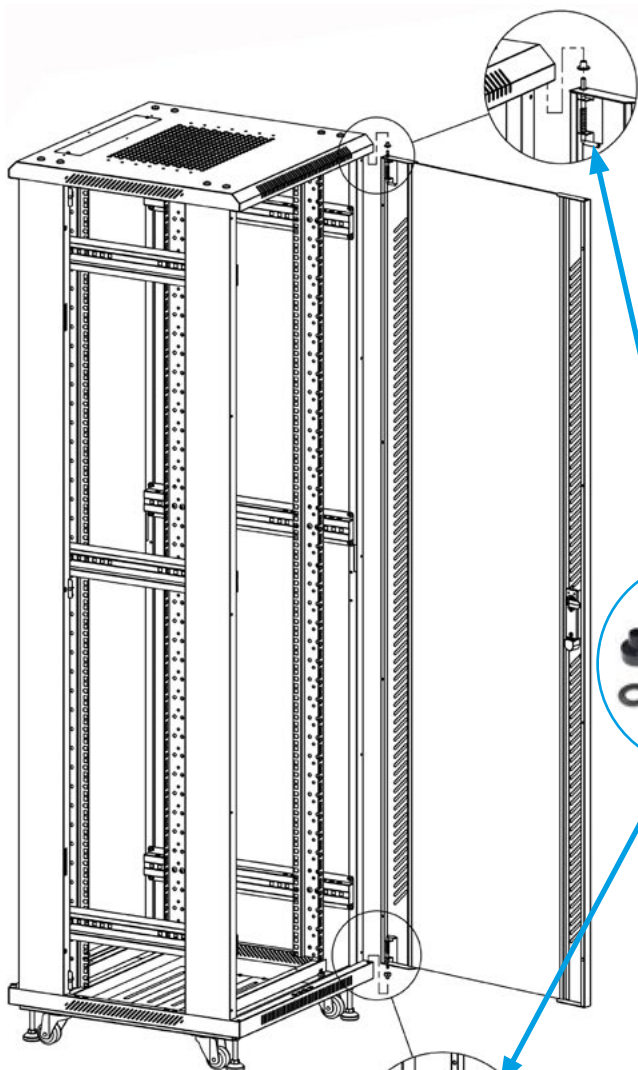
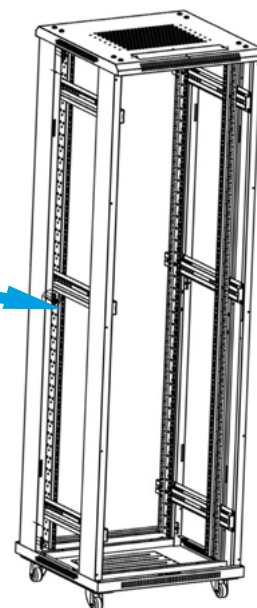
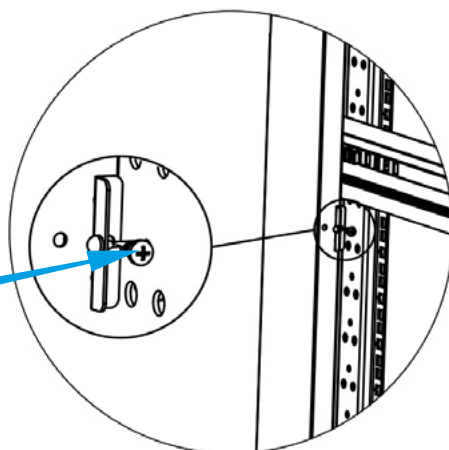

Korak 11. Pripravite i postavite distancere vrata (stavka W) za prednja vrata i zadnji panel (stavke A i B) na odgovarajuća mesta. Bočne panele (stavka C) montirajte na samom kraju.











1. Инструкция по сборке

i **Обязательно строго следуйте инструкциям в данном руководстве.**

1.1 Подготовка

Подготовьте достаточное свободное место на поверхности, на которой будет выполняться сборка. Аккуратно извлеките все элементы из транспортной коробки. Дальнейшие инструкции по сборке будут основаны на предоставленной схеме

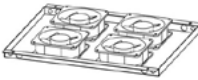
1.1.1. Таблица аксессуаров

| Детали шкафа | | | | |
|--------------|---------------------------|---|---------------------------------|------------------------|
| № элемента | Наименование элемента | Рисунок элемента | Требуемое количество | Количество в комплекте |
| Элемент А | Передняя стеклянная дверь |  | 1 шт. | 1 шт. |
| Элемент В | Задняя панель |  | 1 шт. | 1 шт. |
| Элемент С | Боковые панели |  | 2 шт. | 2 шт. |
| Элемент D | Рама |  | 2 шт. | 2 шт. |
| Элемент E | Верхняя крышка |  | 1 шт. | 1 шт. |
| Элемент F | Нижняя крышка |  | 1 шт. | 1 шт. |
| Элемент G | Поперечина |  | 15U~27U 4 шт. 32U~42U 6 шт. | |
| Элемент H | Полка для вентиляторов |  | 1 шт. | 1 шт. |
| Элемент I | Монтажные направляющие |  | 4 шт. | 4 шт. |
| Элемент J | Заглушка верхней панели |  | Плоский 3 шт. Рифлёный 4 шт. | |

| | | | | |
|-----------|----------------------|--|---------------------------------|-------|
| Элемент К | Регулируемые ножки |  | 4 шт. | 4 шт. |
| Элемент L | Колеса с тормозами |  | 4 шт. | 4 шт. |
| Элемент М | Ограничители двери |  | 15U~27U 8 шт. 32U~42U 12 шт. | |
| Элемент N | Замок передней двери |  | 1 шт. | 1 шт. |
| Элемент O | Замок задней панели |  | 3 шт. | 3 шт. |
| Элемент W | Проставки двери |  | 2 шт. | 4 шт. |

| Винты | | | | |
|------------|--|---|----------------------|------------------------|
| № элемента | Наименование элемента | Рисунок элемента | Требуемое количество | Количество в комплекте |
| Элемент Q | Винт с внутренним шестигранником М8 |  | 16 шт. | 17 шт. |
| Элемент R | Самонарезающие винты М5*10 |  | 15U~27U 36 шт. | 40 шт. |
| | | | 32U~42U 44 шт. | 50 шт. |
| Элемент S | Самонарезающие винты М4*8 |  | 15U~27U 20 шт. | 23 шт. |
| | | | 32U~42U 26 шт. | 30 шт. |
| Элемент Т | Клеточная гайка М6 |  | 15U~27U 32 шт. | 35 шт. |
| | | | 32U~42U 48 шт. | 50 шт. |
| Элемент U | Винт с внутренним шестигранником М6х12 |  | 15U~27U 32 шт. | 35 шт. |
| | | | 32U~42U 48 шт. | 52 шт. |
| Элемент V | Дополнительный винт и гайка М6 |  | 20 шт. | 20 шт. |

2. Этапы сборки

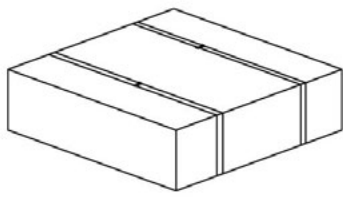

**ВЕРХНЯЯ И НИЖНЯЯ
УПАКОВКА 1/3**

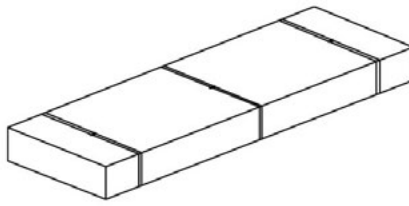

**ПЕРЕДНЯЯ ДВЕРЬ, ЗАДНЯЯ
ПАНЕЛЬ И БОКОВЫЕ ПАНЕЛИ 2/3**

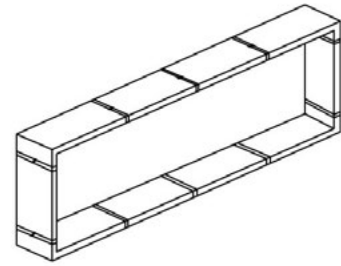

УПАКОВКА РАМЫ 3/3

Шаг 1. Снимите замок передней двери (элемент N), замки боковых панелей и замок задней панели (элемент O); компоненты находятся в упаковке 1/3. Затем снимите переднюю стеклянную дверь (элемент A), заднюю панель (элемент B) и боковые панели (элемент C) из упаковки 2/3. На этом этапе начинаем устанавливать замки на указанные компоненты.



Шаг 2. Распакуйте детали рамы (элемент J) из упаковки 3/3. Затем расположите рамы параллельно друг другу, повернув квадратные отверстия внутрь. Нижнюю часть рамы можно распознать по элементу для установки заземления.

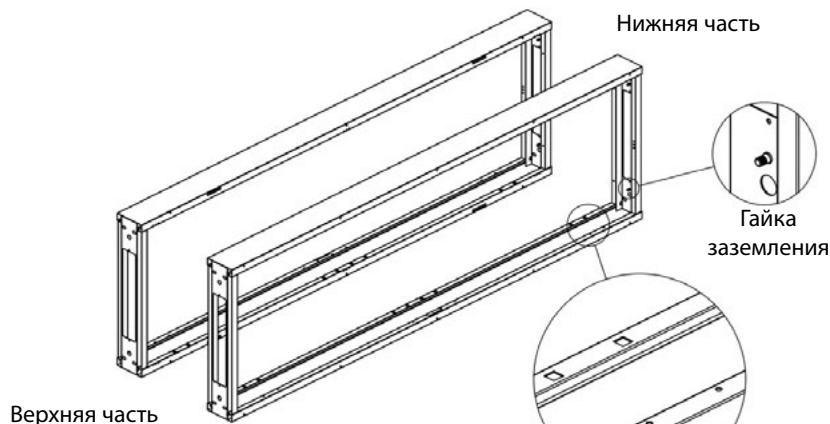

Шаг 3. Установите верхнюю крышку (элемент E) на верхнюю часть рамы (элемент D), затем используйте винт с внутренним шестигранником M8 (элемент Q), чтобы собрать их вместе.

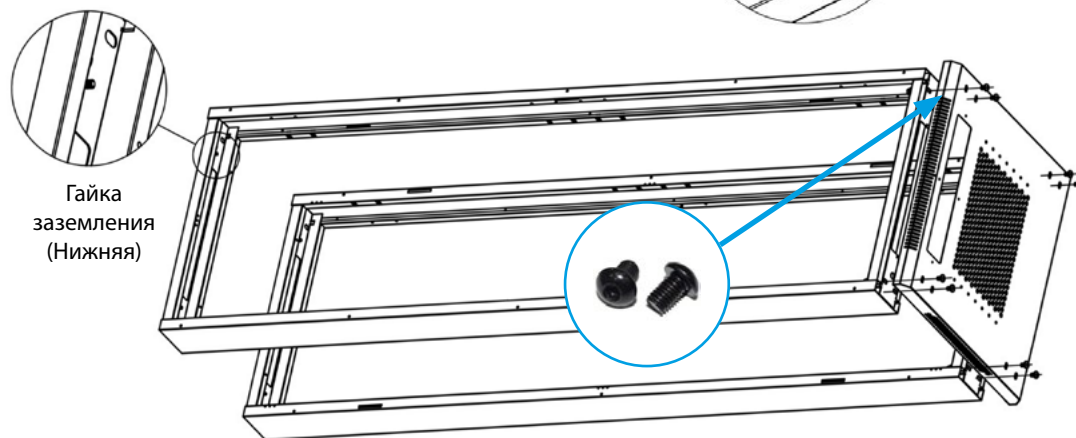

Шаг 4. Установите нижнюю крышку (элемент F) на нижнюю часть рамы (элемент D), затем используйте болт с внутренним шестигранником M8 (элемент Q), чтобы соединить их.

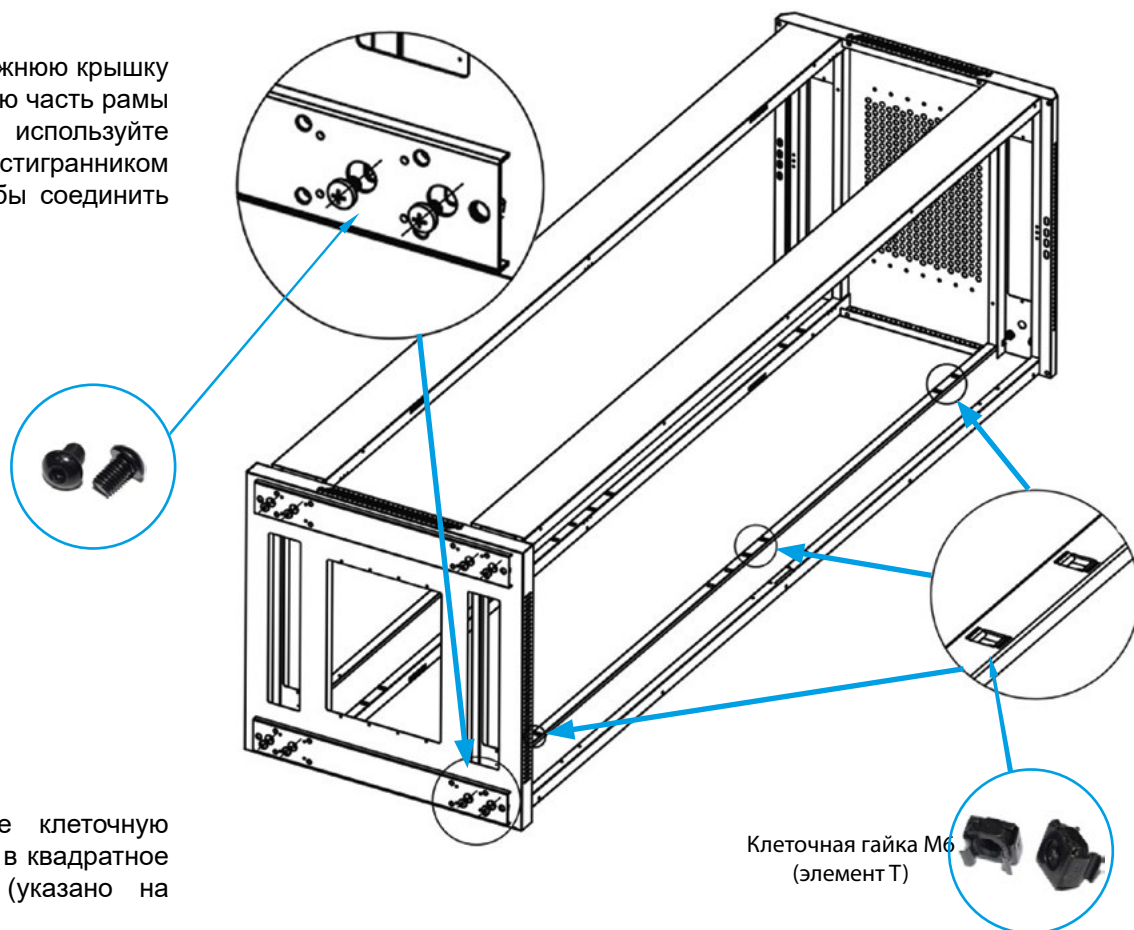

Шаг 4а. Установите клеточную гайку M6 (элемент T) в квадратное отверстие в раме (указано на рисунке).

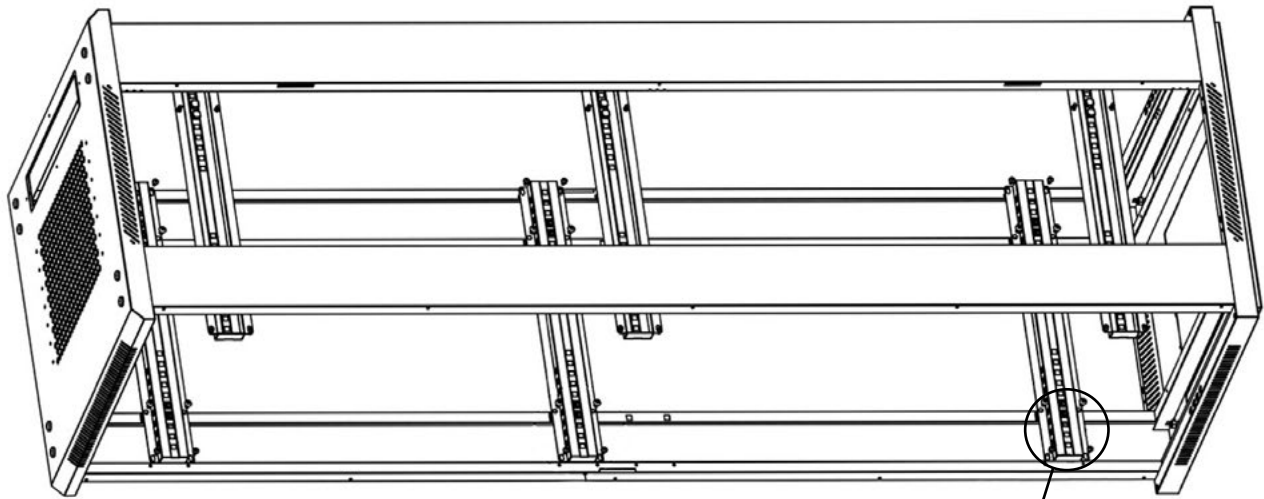

Болт с внутренним шестигранником М6 (элемент U)

Шаг 5. Подготовьте клеточные гайки М6 (элемент Т) и закрепите их на поперечине (элемент G), затем установите поперечину на раму (элемент D), избегая отверстия фиксации в раме. Используйте винт с внутренним шестигранником М6 (элемент U) и самонарезающий винт М5 (элемент R), чтобы закрепить поперечину.

Самонарезающий винт М5 (элемент R)

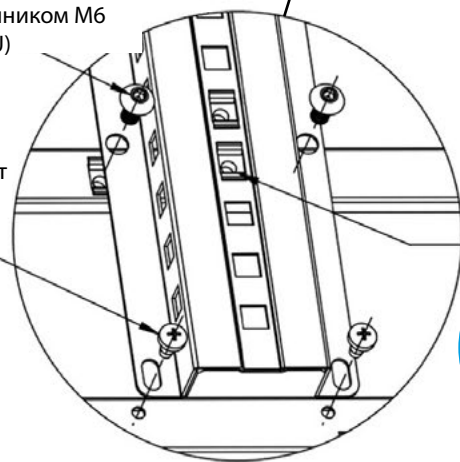

Клеточная гайка М6 (элемент Т)

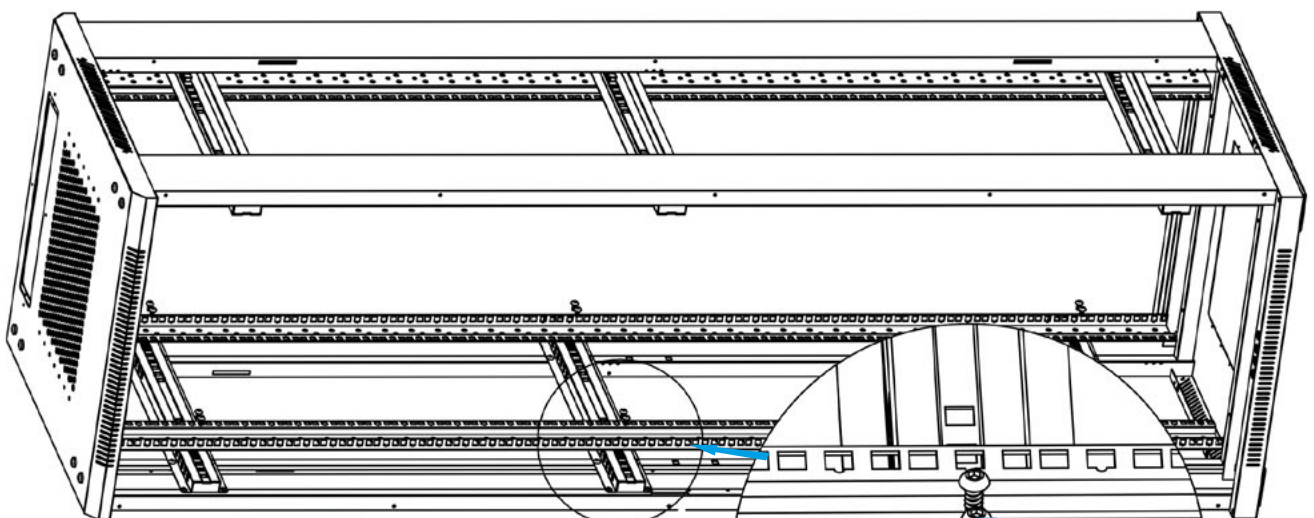

Болт с внутренним шестигранником М6 (элемент U)

Шаг 6. Подготовьте монтажные винты М6 (элемент U). Используйте винты, чтобы закрепить вертикальные монтажные направляющие (элемент I) к горизонтальным поперечинам (элемент G).

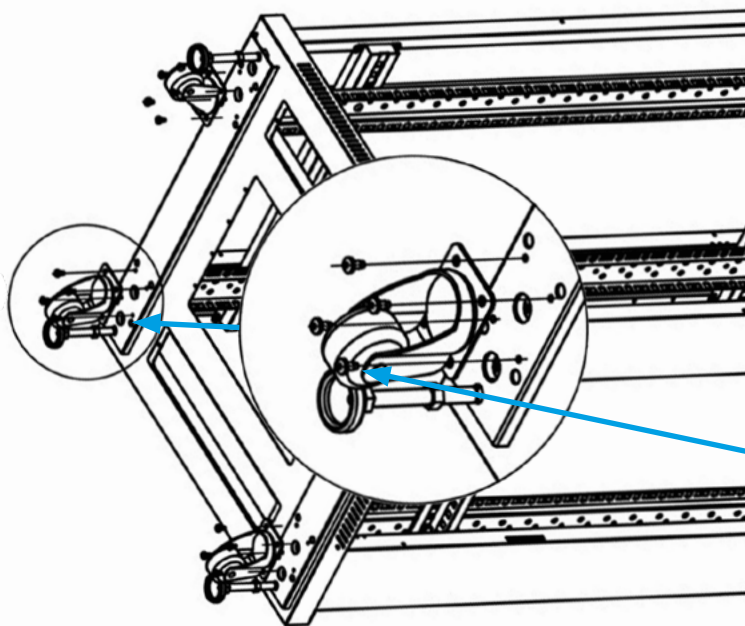

Шаг 7. Подготовьте самонарезающие винты M5 (элемент R), чтобы закрепить четыре колеса с тормозами (элемент L) на нижней крышке (элемент F). Затем установите регулируемые ножки (элемент K) на нижнюю крышку.



Самонарезающий винт M5 (элемент R)

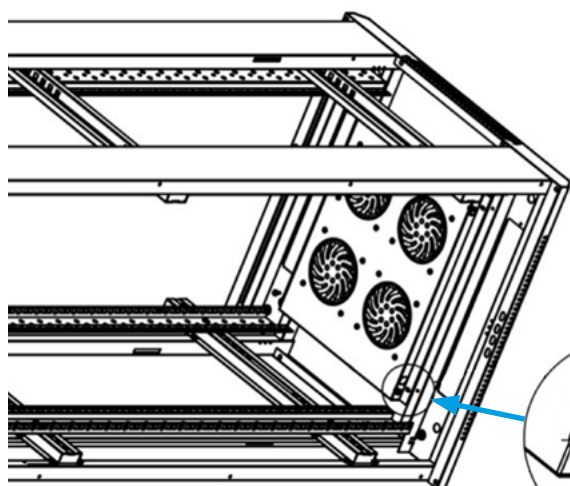

Шаг 8. Подготовьте самонарезающие винты M5 (элемент R), затем используйте их, чтобы закрепить полку для вентиляторов (элемент H) на раме RACK (элемент D).



Самонарезающий винт M5 (элемент R)

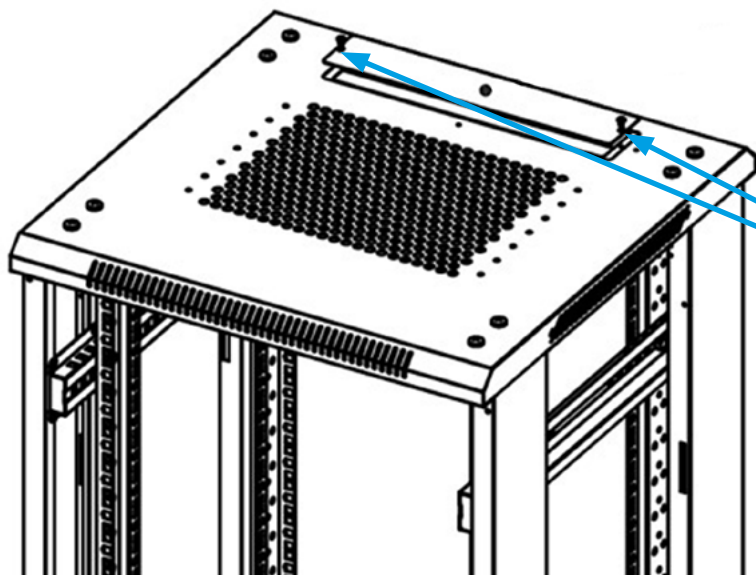

Шаг 9. Подготовьте и используйте самонарезающий винт M4 (элемент S), чтобы закрепить заглушку верхней панели (элемент J).



Самонарезающий винт M4 (элемент S)

Шаг 10. Подготовьте и используйте самонарезающие винты М4 (элемент S), чтобы закрепить ограничители двери (элемент М). Для размеров 15U~27U (8 шт.), 32U~47U (12 шт.).



Самонарезающий винт М4 (элемент S)

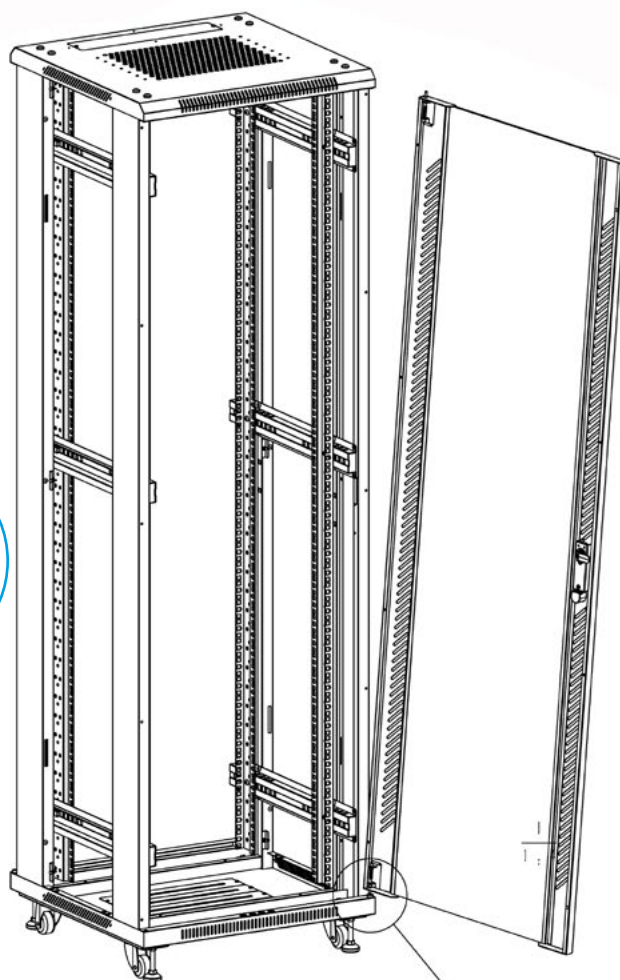
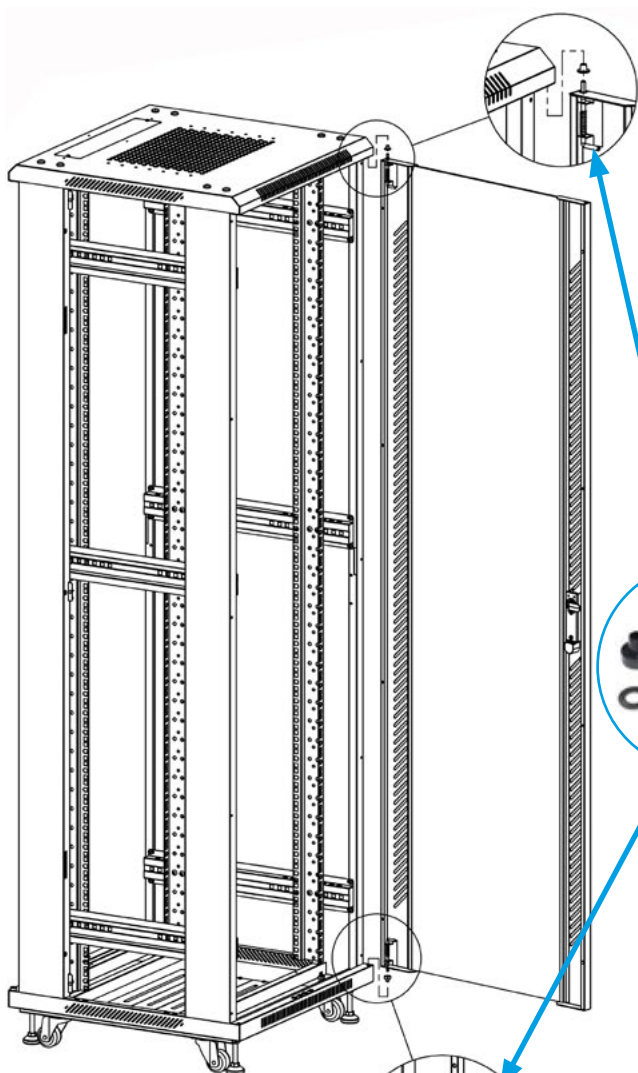
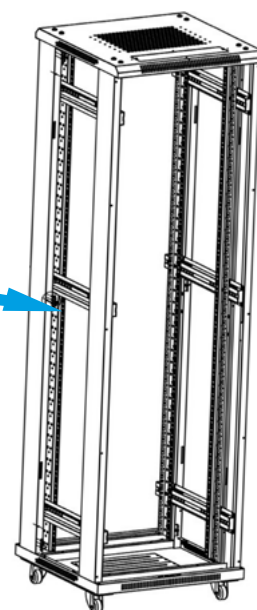
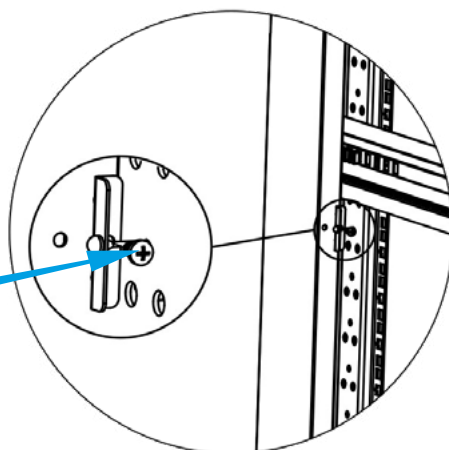

Шаг 11. Подготовьте и установите проставки двери (элемент W) для передней двери и задней панели (элементы А и В) в соответствующие места. Боковые панели (элемент С) установите в самом конце.











1. Οδηγίες συναρμολόγησης





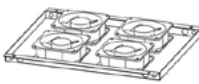

i Βεβαιωθείτε ότι ακολουθείτε αυστηρά τις οδηγίες αυτού του εγχειριδίου.

1.1 Προετοιμασία

Προετοιμάστε επαρκή ελεύθερο χώρο στην επιφάνεια όπου θα πραγματοποιηθεί η συναρμολόγηση. Αφαιρέστε προσεκτικά όλα τα στοιχεία από το κιβώτιο μεταφοράς. Οι επόμενες οδηγίες συναρμολόγησης θα βασιστούν στο παρεχόμενο διάγραμμα

1.1.1. Πίνακας εξαρτημάτων

| Μέρη του ντουλαπιού | | | | |
|---------------------|-------------------------|---|--------------------------------------|------------------|
| Αρ. στοιχείου | Όνομα στοιχείου | Σχέδιο στοιχείου | Απαιτούμενη ποσότητα | Ποσότητα στο σετ |
| Στοιχείο Α | Μπροστινή γυάλινη πόρτα |  | 1 τεμ. | 1 τεμ. |
| Στοιχείο Β | Πίσω πάνελ |  | 1 τεμ. | 1 τεμ. |
| Στοιχείο C | Πλαϊνά πάνελ |  | 2 τεμ. | 2 τεμ. |
| Στοιχείο D | Πλαίσιο |  | 2 τεμ. | 2 τεμ. |
| Στοιχείο E | Επάνω κάλυμμα |  | 1 τεμ. | 1 τεμ. |
| Στοιχείο F | Κάτω κάλυμμα |  | 1 τεμ. | 1 τεμ. |
| Στοιχείο G | Εγκάρσια δοκός |  | 15U~27U 4 τεμ. 32U~42U 6 τεμ. | |
| Στοιχείο Η | Ράφι ανεμιστήρων |  | 1 τεμ. | 1 τεμ. |
| Στοιχείο Ι | Ράγες στήριξης |  | 4 τεμ. | 4 τεμ. |
| Στοιχείο J | Καπάκι επάνω πάνελ |  | Επίπεδο 3 τεμ. Με αυλάκωση 4 τεμ. | |

| | | | | |
|------------|-----------------------------|--|-----------------------------------|--------|
| Στοιχείο Κ | Ρυθμιζόμενα πόδια |  | 4 τεμ. | 4 τεμ. |
| Στοιχείο Λ | Τροχοί με φρένα |  | 4 τεμ. | 4 τεμ. |
| Στοιχείο Μ | Στοπ πόρτας |  | 15U~27U 8 τεμ. 32U~42U 12 τεμ. | |
| Στοιχείο Ν | Κλειδαριά μπροστινής πόρτας |  | 1 τεμ. | 1 τεμ. |
| Στοιχείο Ο | Κλειδαριά πίσω πάνελ |  | 3 τεμ. | 3 τεμ. |
| Στοιχείο W | Αποστάτες πόρτας |  | 2 τεμ. | 4 τεμ. |

| Βίδες | | | | |
|---------------|-------------------------------|---|----------------------|------------------|
| Αρ. στοιχείου | Όνομα στοιχείου | Σχέδιο στοιχείου | Απαιτούμενη ποσότητα | Ποσότητα στο σετ |
| Στοιχείο Q | Βίδα Allen M8 |  | 16 τεμ. | 17 τεμ. |
| Στοιχείο R | Αυτοκωχλιούμενες βίδες M5*10 |  | 15U~27U 36 τεμ. | 40 τεμ. |
| | | | 32U~42U 44 τεμ. | 50 τεμ. |
| Στοιχείο S | Αυτοκωχλιούμενες βίδες M4*8 |  | 15U~27U 20 τεμ. | 23 τεμ. |
| | | | 32U~42U 26 τεμ. | 30 τεμ. |
| Στοιχείο T | Παξιμάδι κλωβού M6 |  | 15U~27U 32 τεμ. | 35 τεμ. |
| | | | 32U~42U 48 τεμ. | 50 τεμ. |
| Στοιχείο U | Βίδα Allen M6x12 |  | 15U~27U 32 τεμ. | 35 τεμ. |
| | | | 32U~42U 48 τεμ. | 52 τεμ. |
| Στοιχείο V | Πρόσθετη βίδα και παξιμάδι M6 |  | 20 τεμ. | 20 τεμ. |

2. Στάδια συναρμολόγησης

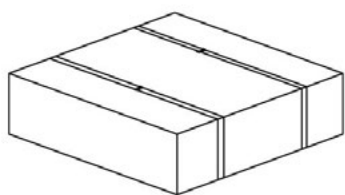

ΠΑΚΕΤΟ ΕΠΑΝΩ ΚΑΙ ΚΑΤΩ 1/3

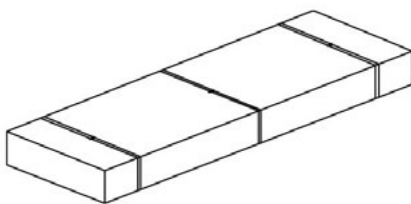

ΜΠΡΟΣΤΙΝΗ ΠΟΡΤΑ, ΠΙΣΩ
ΠΑΝΕΛ ΚΑΙ ΠΛΑΪΝΑ ΠΑΝΕΛ 2/3

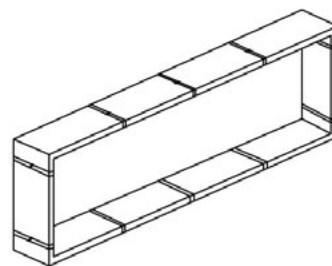

ΠΑΚΕΤΟ ΠΛΑΪΣΙΟΥ 3/3

Βήμα 1. Αφαιρέστε την κλειδαριά της μπροστινής πόρτας (στοιχείο N), τις κλειδαριές των πλαϊνών πάνελ και την κλειδαριά του πίσω πάνελ (στοιχείο O)· τα εξαρτήματα βρίσκονται στο πακέτο 1/3. Έπειτα αφαιρέστε την μπροστινή γυάλινη πόρτα (στοιχείο A), το πίσω πάνελ (στοιχείο B) και τα πλαϊνά πάνελ (στοιχείο C) από το πακέτο 2/3. Σε αυτό το στάδιο ξεκινάμε τοποθετώντας κλειδαριές στα παραπάνω εξαρτήματα.

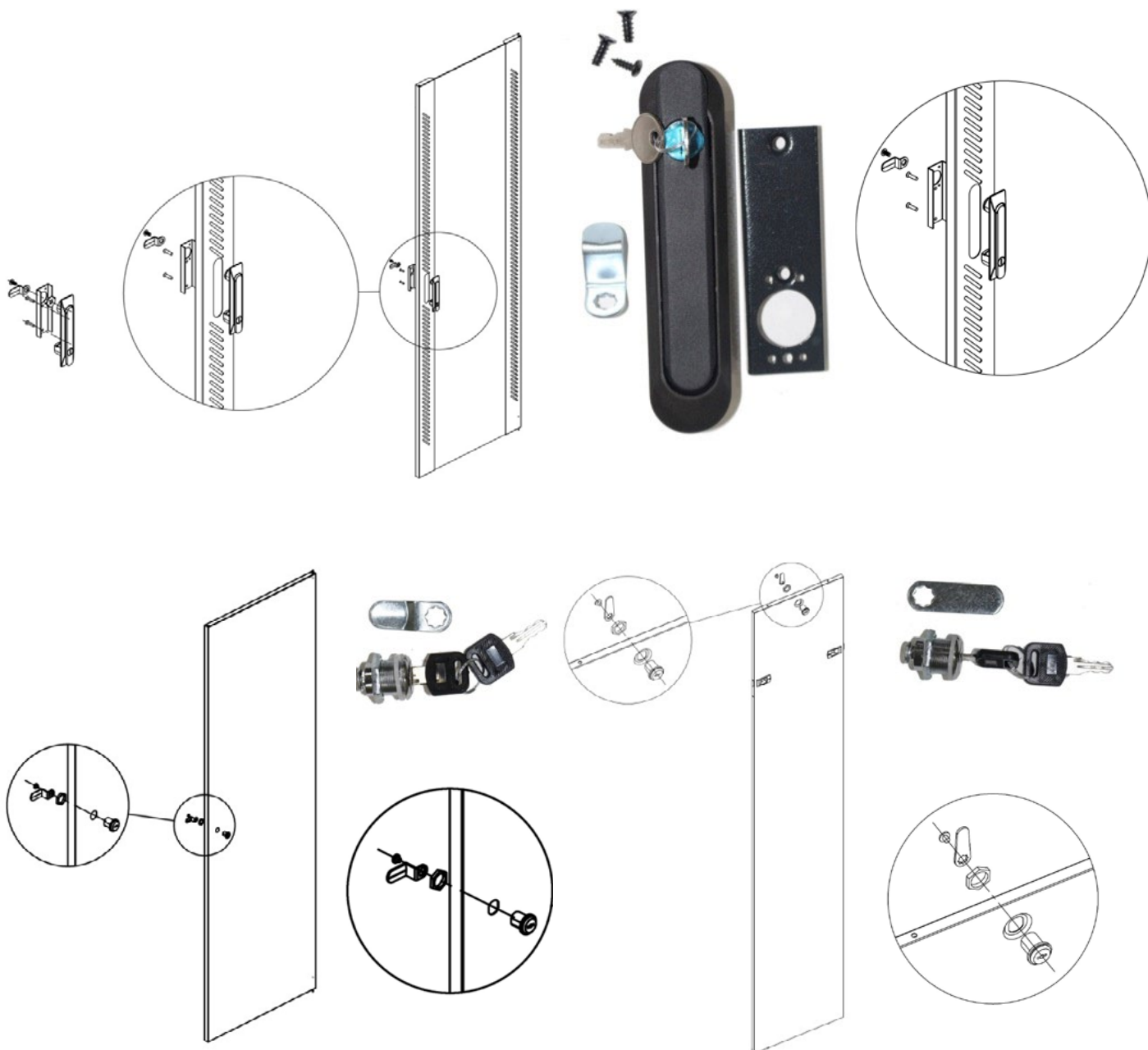

Βήμα 2. Αποσυσκευάστε τα μέρη του πλαισίου (στοιχείο J) από το πακέτο 3/3. Στη συνέχεια τοποθετήστε τα πλαίσια παράλληλα μεταξύ τους, με τις τετράγωνες οπές στραμμένες προς τα μέσα. Μπορείτε να αναγνωρίσετε το κάτω μέρος του πλαισίου από το στοιχείο για την εγκατάσταση της γείωσης.

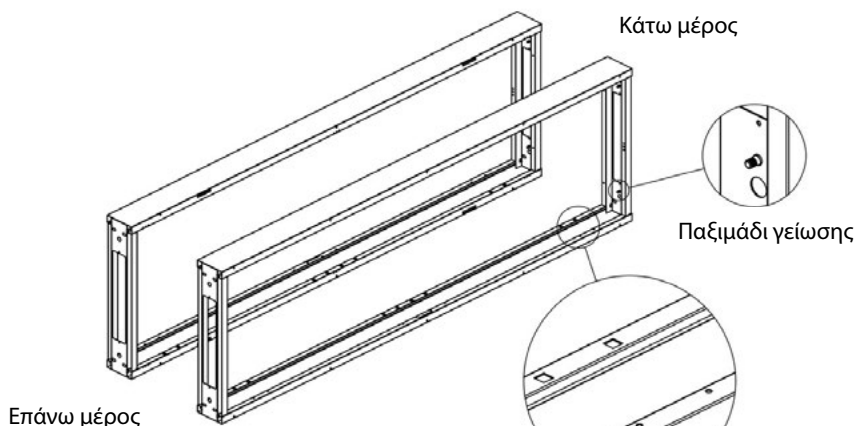

Βήμα 3. Τοποθετήστε το επάνω κάλυμμα (στοιχείο E) στο επάνω μέρος του πλαισίου (στοιχείο D), έπειτα χρησιμοποιήστε μία βίδα Allen M8 (στοιχείο Q) για να τα συναρμολογήσετε μαζί.

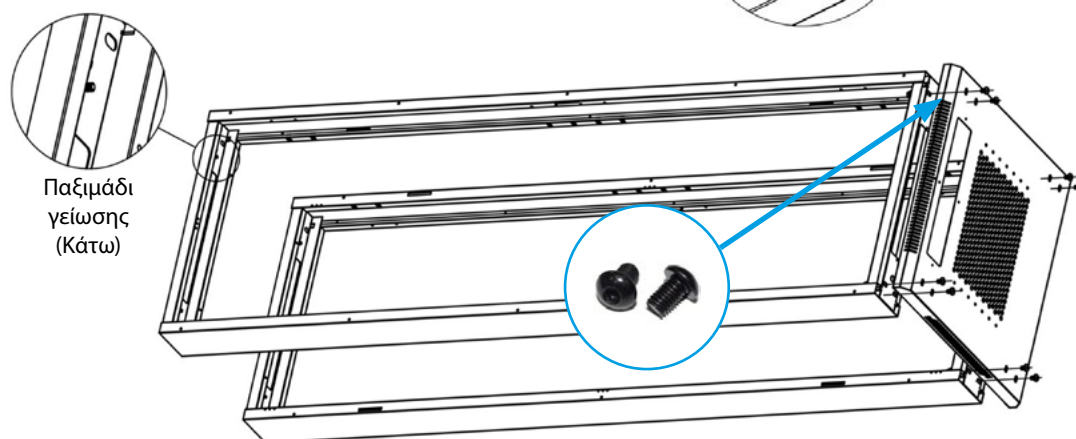

Βήμα 4. Τοποθετήστε το κάτω κάλυμμα (στοιχείο F) στο κάτω μέρος του πλαισίου (στοιχείο D) και στη συνέχεια χρησιμοποιήστε μία βίδα Allen M8 (στοιχείο Q) για να τα ενώσετε.

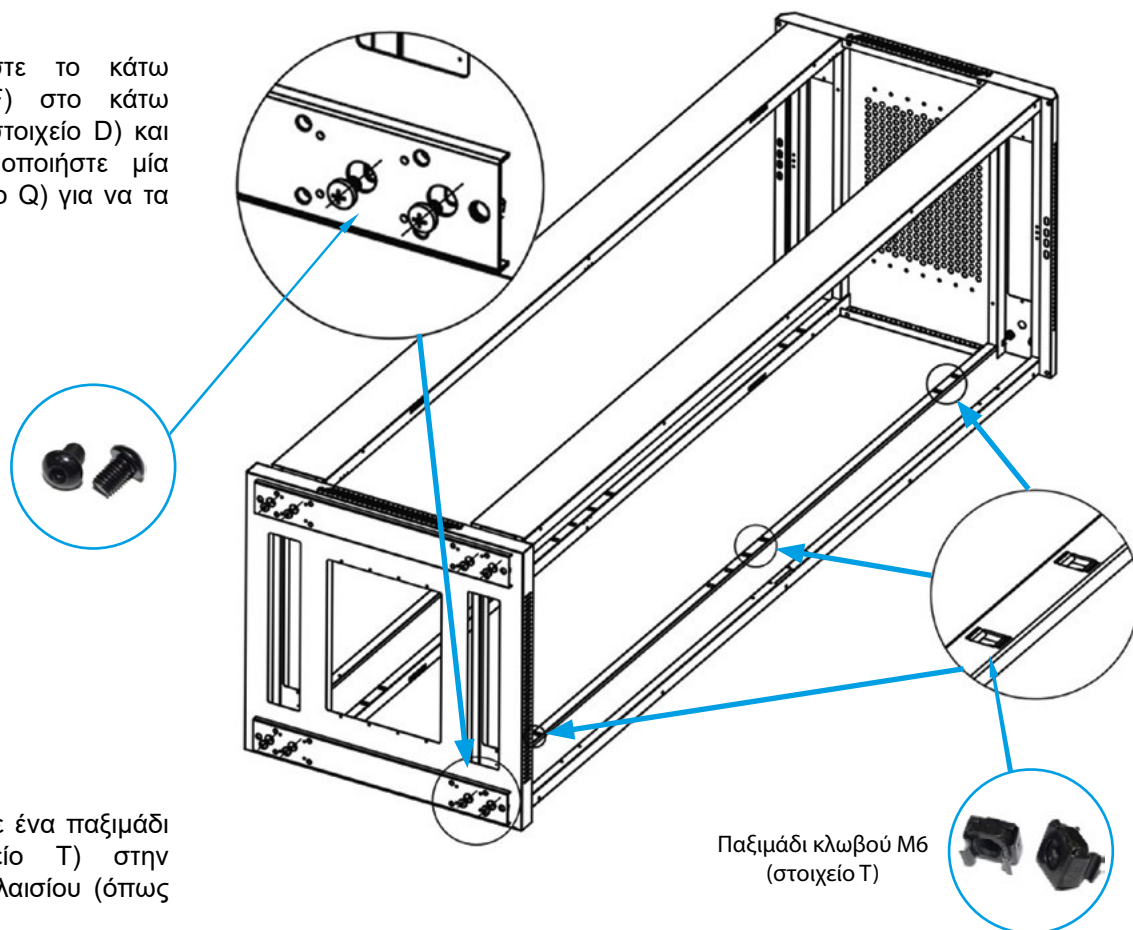

Βήμα 4a. Τοποθετήστε ένα παξιμάδι κλωβού M6 (στοιχείο T) στην τετράγωνη οπή του πλαισίου (όπως φαίνεται στο σχήμα).

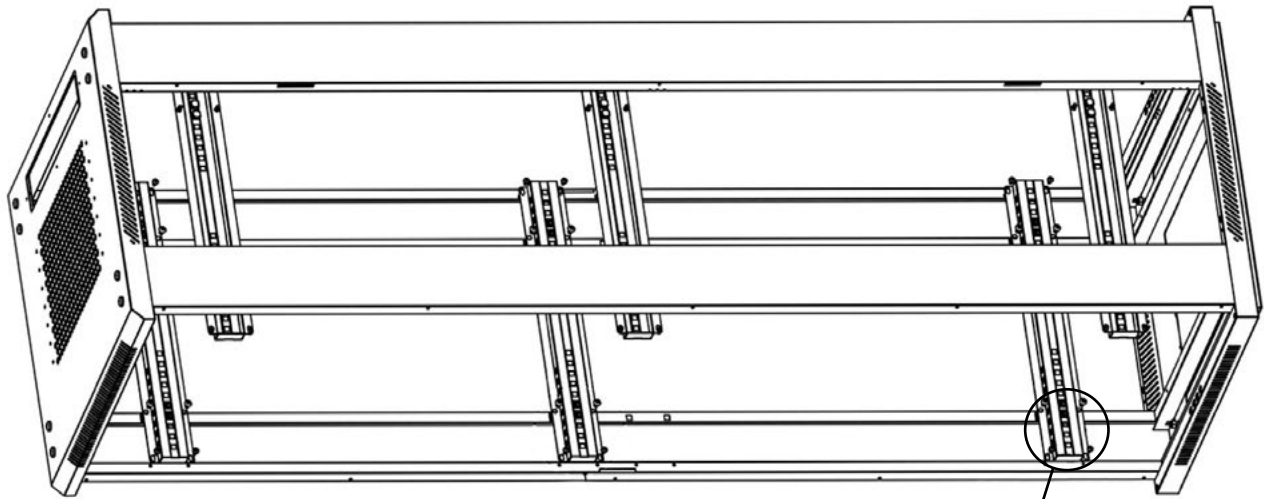

Βίδα Allen M6
(στοιχείο U)

Αυτοκοχλιούμενη βίδα
M5 (στοιχείο R)

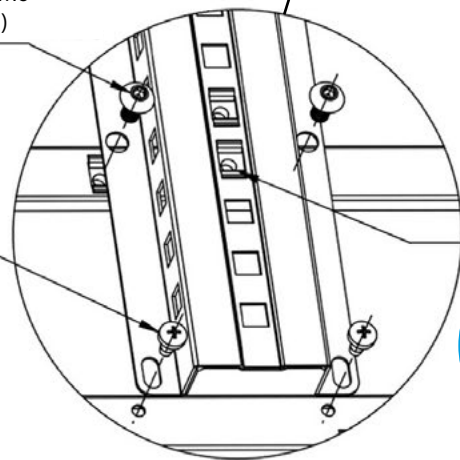

Παξιμάδι
κλωβού M6
(στοιχείο T)



Βήμα 5. Προετοιμάστε παξιμάδια κλωβού M6 (στοιχείο T) και στερεώστε τα στην εγκάρσια δοκό (στοιχείο G), έπειτα τοποθετήστε την εγκάρσια δοκό στο πλαίσιο (στοιχείο D) αποφεύγοντας την οπή κλειδώματος στο πλαίσιο. Χρησιμοποιήστε μία βίδα Allen M6 (στοιχείο U) και μία αυτοκοχλιούμενη βίδα M5 (στοιχείο R) για να στερεώσετε την εγκάρσια δοκό.

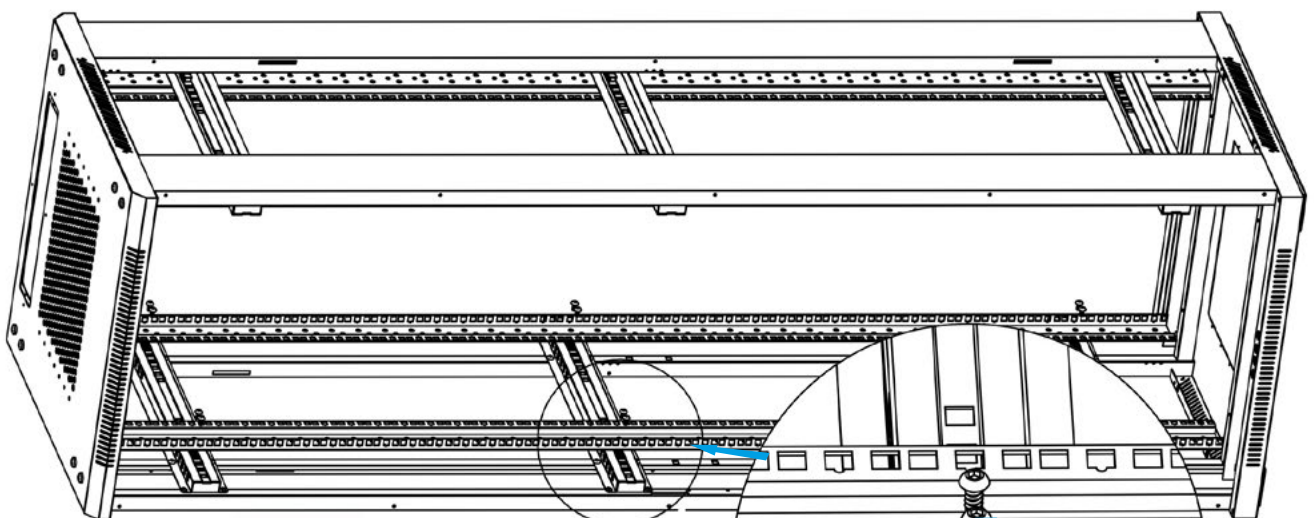

Βίδα Allen M6
(στοιχείο U)

Βήμα 6. Προετοιμάστε τις βίδες στήριξης M6 (στοιχείο U). Χρησιμοποιήστε τις βίδες για να στερεώσετε τις κάθετες ράγες στήριξης (στοιχείο I) στις οριζόντιες εγκάρσιες δοκούς (στοιχείο G).

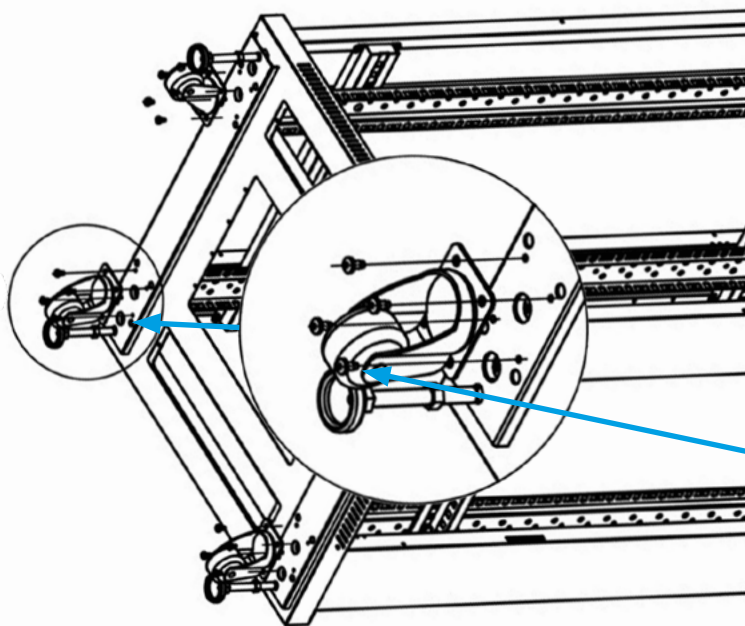

Βήμα 7. Προετοιμάστε τις αυτοκοχλιούμενες βίδες M5 (στοιχείο R) για να στερεώσετε τους τέσσερις τροχούς με φρένα (στοιχείο L) στο κάτω κάλυμμα (στοιχείο F). Στη συνέχεια τοποθετήστε τα ρυθμιζόμενα πόδια (στοιχείο K) στο κάτω κάλυμμα.



Αυτοκοχλιούμενη βίδα M5 (στοιχείο R)

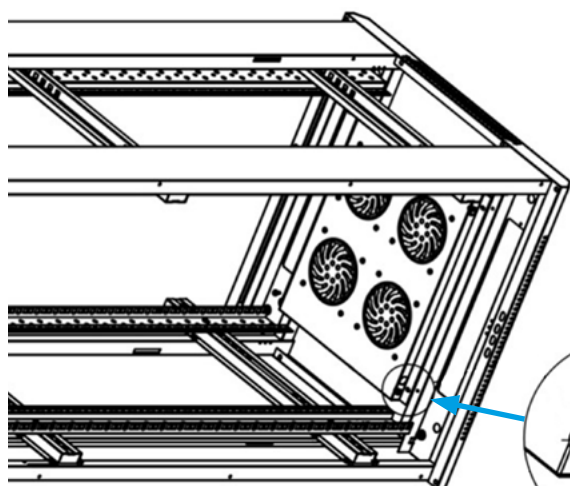

Βήμα 8. Προετοιμάστε τις αυτοκοχλιούμενες βίδες M5 (στοιχείο R) και χρησιμοποιήστε τες για να στερεώσετε το ράφι ανεμιστήρων (στοιχείο H) στο πλαίσιο RACK (στοιχείο D).



Αυτοκοχλιούμενη βίδα M5 (στοιχείο R)

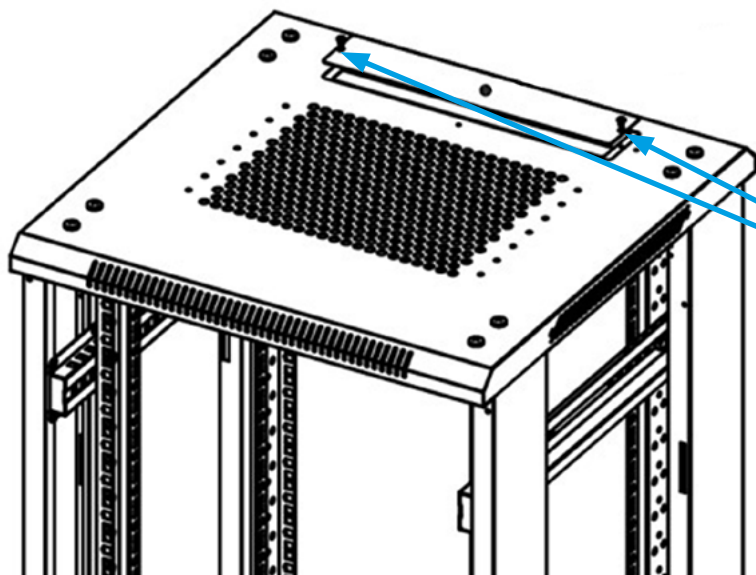

Βήμα 9. Προετοιμάστε και χρησιμοποιήστε μία αυτοκοχλιούμενη βίδα M4 (στοιχείο S) για να στερεώσετε το καπάκι του επάνω πάνελ (στοιχείο J).



Αυτοκοχλιούμενη βίδα M4 (στοιχείο S)

Βήμα 10. Προετοιμάστε και χρησιμοποιήστε αυτοκοχλιούμενες βίδες M4 (στοιχείο S) για να στερεώσετε τα στοπ πόρτας (στοιχείο M). Για μεγέθη 15U~27U (8 τεμ.), 32U~47U (12 τεμ.).



Αυτοκοχλιούμενη βίδα M4 (στοιχείο S)

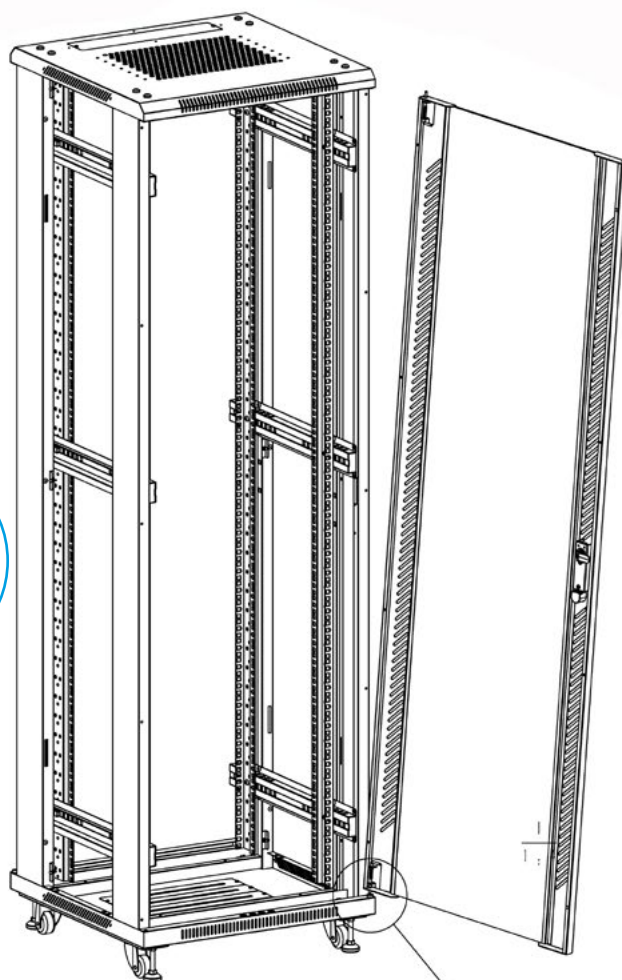
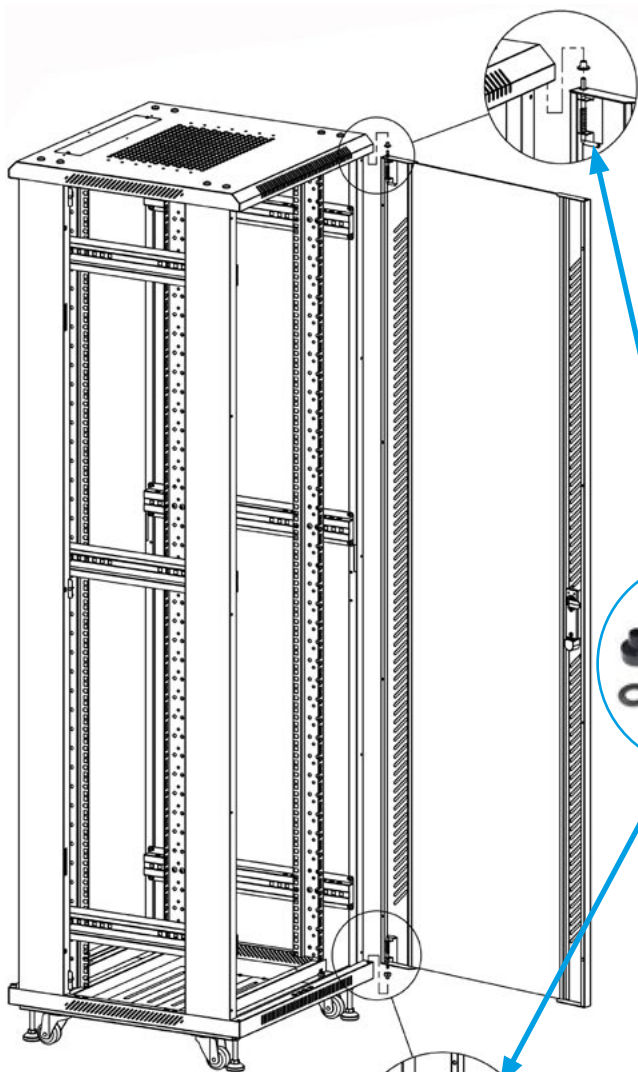
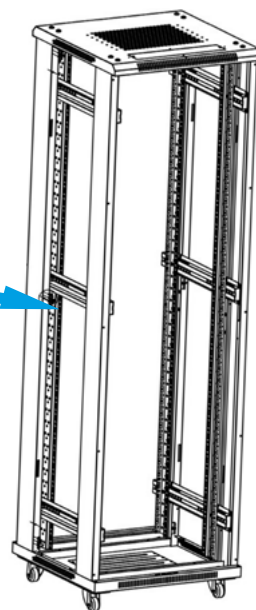
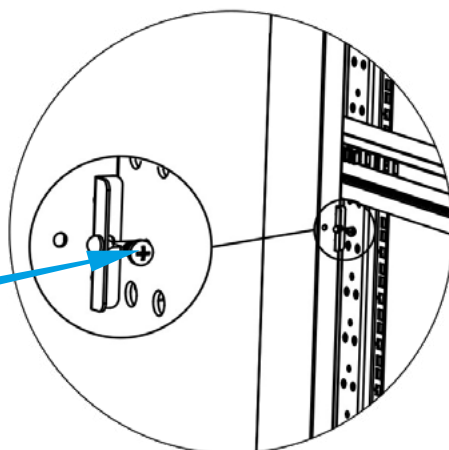

Βήμα 11. Προετοιμάστε και τοποθετήστε τους αποστάτες πόρτας (στοιχείο W) για την μπροστινή πόρτα και το πίσω πάνελ (στοιχεία A και B) στα κατάλληλα σημεία. Τοποθετήστε τα πλαϊνά πάνελ (στοιχείο C) στο τέλος.



E-mail: support@lanberg.pl | support@lanberg.eu

www.lanberg.pl | www.lanberg.eu

